

Presto TT & WT and ECO A HTT & HUE Series Tilt Tables



Installation, Operation and Service Manual

Model Number _____

Serial # _____

Date Placed in Service _____

**IMPORTANT: READ CAREFULLY
BEFORE INSTALLING OR OPERATING LIFT**

Part orders are subject to a \$50 minimum charge.



This manual was current at the time of printing. To obtain the latest, most updated version, please contact Presto/ECO A Lifts Customer Service Department or go to our website: www.PrestoLifts.com where you will find a complete list of current owner's manuals to print.

CONTENTS

SECTION 1: Introduction	4
Responsibility of Owners and Users	5
Safety Alert Symbols and Signal Words	6
SECTION 2: Safety	7
SECTION 3: Installation	8
A. Inspection	8
B. Installing	8
C. Hydraulics	8
D. Testing the Tilter with No Load	9
SECTION 4: Operation	9
A. Method of Operation	9
B. Operation Procedures	9
SECTION 5: Maintenance	10
A. Routine Maintenance	10
B. Troubleshooting Maintenance	10
PARTS / QUALITY ISSUES / GENERAL	16
ORDERING REPLACEMENT PARTS	17
LIST OF FIGURES:	
Figure 1 Hydraulic Schematic	12
Figure 3 Electrical Schematic Pump Unit Single Phase 115 Volts AC	13
Figure 4 Electrical Schematic Pump Unit 1 Phase 208, 240 Volts AC	14
Figure 5 Labels and Label Location	15
Figure 6 WT Series Wide Base Tilt Specifications	19
Figure 7 Labels and Locations	15
LIST OF TABLES:	
Table 1 Hydraulic Oil Specifications	14
WARRANTY	Back Page

SECTION 1

INTRODUCTION

The lifts and tilters are designed for lifting, tilting and position a wide variety of loads. These tilters are capable of being mounted on other Presto-ECO tables and stands or lagged directly to the floor. These lifts are designed for in-plant/non-hazardous location use only.

This manual attempts to provide all of the information necessary for the safe and proper installation, operation and maintenance of these tilters. It is important that this manual be read by all personnel involved with the installation, maintenance or operation of the tilter. If the manual does not address an application, call your distributor or Presto-ECO Lifts for assistance. Additional manuals are available upon request at www.PrestoLifts.com.

The tilter has a nameplate that provides the load capacity rating, serial number and model identification. Please refer to these numbers when ordering parts or requesting further information.

Responsibility of Owners and Users

Inspection and Maintenance

The device shall be inspected and maintained in proper working order in accordance with Presto-ECO's owner's manual.

Removal from Service

Any device not in safe operating condition such as, but not limited to, excessive leakage, missing rollers, pins, or fasteners, any bent or cracked structural members, cut or frayed electric, hydraulic, or pneumatic lines, damaged or malfunctioning controls or safety devices, etc. shall be removed from service until it is repaired to the original manufacturer's standards.

Repairs

All repairs shall be made by qualified personnel in conformance with Presto's instructions.

Operators

Only trained personnel and authorized personnel shall be permitted to operate these lifts.

Before Operation

Before using the device, the operator shall have:

- Read and/or had explained, and understood, the manufacturer's operating instructions and safety rules.
- Inspected the device for proper operation and condition. Any suspect item shall be carefully examined and a determination made by a qualified person as to whether it constitutes a hazard. All items not in conformance with Presto's specification shall be corrected before further use of these lifts.

During Operation

The device shall only be used in accordance with this owner's manual.

- Do not overload.
- Ensure that all safety devices are operational and in place.

Modifications or Alterations

Modifications or alterations to any Presto-ECO industrial positioning equipment shall be made only with written permission from Presto.

SAFETY ALERT SYMBOLS AND SIGNAL WORDS

The safety of all persons operating, maintaining, repairing, or in the vicinity of this equipment is of paramount concern. This is a powerful machine with moving parts, and is capable of causing personal injury if proper precautions are not taken. Therefore, throughout this manual, certain hazards have been identified which may occur in the use of the machine, and there are appropriate instructions or precautions which should be taken to avoid these hazards. In some cases, there are consequences which may occur if instructions or precautions are not followed. Below are the symbols and signal words along with their definitions referenced from ANSI Z535.4 - Product Safety Signs and Labels.

4.11 Safety Alert Symbols: A symbol that indicates a hazard. It is composed of an equilateral triangle surrounding an exclamation mark. The safety alert symbol is only used on hazard alerting signs. It is not used on safety notice and safety instructions signs.



A): for use with DANGER signal word; (safety white triangle, safety red exclamation mark, safety red background)

B): for use with WARNING signal word; (safety black triangle, safety orange exclamation mark)

C): for use with CAUTION signal word; (safety black triangle, safety yellow exclamation mark)

D) and E): for use with DANGER, WARNING, or CAUTION signal word; (D: is a safety yellow triangle with a black border and safety black exclamation mark; E: is a safety yellow triangle with a safety black exclamation mark and a safety yellow border around a safety black band)

NOTE: D and E are provided to allow for consistency with certain ISO standards such as ISO 3864-1 and ISO 3864-2.

4.14 Signal Words: The words used in the signal word panel. The signal words for hazard alerting signs are “DANGER,” “WARNING,” and “CAUTION.” Safety notice signs use the signal word “NOTICE.” Safety instruction signs use signal words that are specific to the situation.



DANGER indicates a hazardous situation which, if not avoided, will result in death or serious injury.



WARNING indicates a hazardous situation which, if not avoided, could result in death or serious injury.



CAUTION indicates a hazardous situation which, if not avoided, could result in minor or moderate injury.



NOTICE is used to address practices not related to physical injury.



SAFETY INSTRUCTIONS (or equivalent) signs indicate specific safety-related instructions or procedures.

NOTE: DANGER, WARNING or CAUTION should not be considered for property damage accidents unless personal injury risk appropriate to these levels is involved.

SECTION 2

SAFETY

The safety of all persons installing, using, servicing, or working near the unit is of paramount concern to Presto-ECO Lifts. The lift is a powerful machine with moving parts, and is **capable of causing personal injury if proper precautions are not taken**. Therefore, throughout this manual, Presto-ECO Lifts have identified certain hazards, which may occur in the use of the unit, and provided appropriate **instructions** or precautions that should be taken to avoid these hazards. In some cases, Presto-ECO Lifts has also pointed out the **consequences** that may occur if Presto-ECO Lifts instructions or precautions are not followed. Presto-ECO Lifts use the following nationally recognized system for identifying the severity of the hazards associated with its products:

⚠ DANGER Immediate hazard that will result in severe personal injury or death.

⚠ WARNING Hazard or unsafe practice, that could result in severe personal injury or death.

⚠ CAUTION Hazard or unsafe practice, that could result in minor personal injury or property damage.

In the interest of safety, please read the entire manual carefully. You must understand the material in this manual before you install, use, or service the unit. If you have any question about any of the instructions in this manual, please contact Presto-ECO Lifts at 1-800-343-9322.

SAFETY INSTRUCTIONS

- Do not perform any repair work on a lift with a load on the platform or with the table in a raised position.
- All personnel must stand clear of the lift when the lift is in motion.
- Do not put hands or feet under lift table.
- Do not perform any repair or maintenance work with the lift in an open position without securing it first with proper maintenance devices.
- Do not stand, sit or climb on the lift at any time.
- Do not use the lift on soft, uneven or unstable surfaces.
- Do not exceed the load capacity rating on the data plate.
- Do not place a load on a moving lift.
- Do not exceed load capacity.
- Place a load in the center of the lift and be sure that the load is secured properly.

⚠WARNING

Do not perform any repair work on a lift in a fully extended position. Unload lift prior to working under or around.

All personnel must stand clear of the lift when the lift is in motion.

Do not put hands or feet under lift.

Do not work under lift without securing it first with proper maintenance devices.

Do not stand, sit or climb on the lift at any time.

Do not use the lift on soft, uneven or unstable surfaces.

Do not exceed the load capacity rating on the data plate.

Do not place a load on a moving lift.

Place a load in the center of the lift and be sure that the load is secured properly.

SECTION 3 INSTALLATION

A. INSPECTION

Upon receipt of the tilters, inspect the equipment completely to determine if there is any shipment damage and that the tilter is complete. *Do not* use the tilter if there appears to be any damage. With the tilter in a collapsed position, check the following:

1. Check for signs of damage, especially to the electricals and hydraulics.
2. Check all connections for tightness. Also check for visible hydraulic liquid around the connections.
3. Check for any physical damage to the frame.
4. Inspect the platform for damage, either twisted or bent.

B. INSTALLING

Read all of the instructions prior to starting or connecting the tilter.

1. Working Area

- a) Make sure that the floor and the operation area is flat, stable, relatively smooth and free from dirt, obstacles and surface defects.
- b) Place the empty tilter in the exact operating area to be sure that there are no encumbrances due to components or equipment in the general area.
- c) Make sure that the complete base of the tilter is in contact with the floor. In order to complete contact with the floor, the base may be shimmed or grouted.
- d) The tilters are provided with anchoring holes on the base. Place the tilter in the exact operating position before spotting and drilling holes for the bolts. Bolt the lift securely using floor lag bolts with a minimum of 2000# pull out strength per bolt.

⚠WARNING

Install the tilter on a solid and stable surface.

⚠CAUTION

All wiring must conform to local code and must be performed by licensed electricians. The standard AC single phase motor requires a 120 volt 20 amp fused outlet, do not remove or replace the plug or cord set provided. Do not use an extension cord.

⚠WARNING

***Do not* tamper with or remove the cover of the electrical junction box. Only authorized, qualified personnel should service the electrical system. Motor direction is critical. This motor has been wired according to its nameplate and should not be tampered with as it may lead to pump or motor failure.**

C. HYDRAULICS

1. Before using the tilter, check the hydraulic oil level by removing the solid plug from the reservoir. Remove the plug, check for oil and add oil if necessary. See the chart below for correct oil level. Replace the plug with the vented plug provided; if the vented plug is not installed you may damage the pump. **Note:** if a vented plug is not available, the solid plug may be modified by drilling a 1/8 diameter hole through the center of the plug and reinstall.

⚠WARNING

***Do not* use automotive hydraulic brake or transmission fluids, they will damage seals and pose a serious fire hazard.**

D. TESTING THE TILTER WITH NO LOAD

Before operating the tilter, read and understand this section.

1. Before testing the tilter, clear the area of any loose material. Be sure the tilter has no obstruction above it or on any side. Using the controls provided, briefly operate the tilter (5-10 seconds). If the tilter begins to rise with a humming sound and functions properly, continue to the full upright position.

⚠ CAUTION

If the tilter does not rise immediately, or there is any operational problem, stop it immediately. Before continuing, check the rotation of the pump and motor and the voltage at motor terminals, again briefly operate the tilter. If the tilter does not move smoothly with the humming sound, stop and review the procedures in the section on troubleshooting (Section 5B).

2. After raising the tilter completely, lower the tilter completely. It should move slowly and smoothly without a humming sound. If the tilter operates properly, raise and lower the tilter and stop at different levels in order to familiarize yourself with the tilter's operations and movements.

⚠ WARNING

As the tilter platform and forks move up and down, pinch points are created at locations near the base of the frame. While operating the tilter the operator should be standing clear of the tilter and container while in use. In that way, the operator's arms, legs or clothing will not be caught in the moving parts. During operations the operator should avoid the pinch point areas which are located on either side of the tilter. See the diagram pointing out the particular pinch points.

SECTION 4 OPERATION

A. METHOD OF OPERATION

All tilters are provided with a special hydraulic relief valve, which is factory preset to the maximum safe capacity of the container tilter (see the nameplate attached to the tilter.) Activating and holding the up switch will energize the motor. The motor is attached to a positive displacement pump which draws hydraulic fluid from the reservoir and transfers it under

pressure to the cylinder. This forces the piston forward and the raise to rise in a thirty (30°) to ninety degree (90°) arc. Releasing the up button will stop the tilter. A check valve between the pump and piston holds the platform in position. Depressing and holding the down button of the switch will energize a solenoid, which allows the oil from the cylinder to return to the reservoir through a preset flow control. This allows the tilter to lower smoothly and at a controlled speed.

⚠ CAUTION

Do not maintain the up button on the switch energized if the tilter does not move or has reached its upper limit. This may cause damage to the motor, pump and controls.

B. OPERATION PROCEDURES

⚠ WARNING

- Do not stand, sit or climb onto the tilter.
- Do not load or unload a moving tilter.
- If the tilter fails to move or exhibits strange movements or sounds, stop immediately. Do not operate the tilter until it has been checked and repaired.
- Obey all warning labels.
- Load the lift only in the lowered position.
- Do not stand near the tilting side when tilting containers of loose parts. Parts may fall out of the container and could harm the operator.

In order to operate the tilter, follow these operating procedures:

1. Read and understand all the instructions before operating. If the tilter has modifications or accessories, read and understand their functions.
2. Load the tilter correctly. Refer to the attached nameplate for load capacity information.
 - a) Load the tilter while it is in the lowered position.
 - b) *Do not* exceed the maximum rated load (note that load capacity is on the nameplate of the tilter).
 - c) Place the load in the center and at the very back of the platform (pivot end).
 - d) If the load is unstable or may become unstable, fasten it into position.
 - e) Use additional precautions when tilting a load of

loose parts. Excessive tilting can cause parts to fall out of the container.

3. Operate the tilter.
 - a) To raise the tilter, press and hold the up button on the switch.
 - b) To lower the tilter, press the down button on the switch.
 - c) Release the button to stop the tilter in either direction.
4. Wait until the tilter has come to a complete stop before loading or unloading.
5. Stand clear of the tilter when operating in order to avoid injury.
6. All people and unrelated objects must stand clear of the lift when operating in order to avoid personal injury or property damage.

SECTION 5

MAINTENANCE

Generally, the tilter lifts will require little maintenance. However, routine inspection and maintenance will minimize costly repairs or hazardous conditions.

⚠WARNING

Before servicing the unit, read and understand this entire section and the section entitled Operating Instructions. Never go under or service a tilter with a load on the platform or with the platform in a raised position. Always service the tilter in a down or chocked position.

A. ROUTINE MAINTENANCE

All routine inspection and maintenance should be performed monthly. When servicing the tilter in a partially or fully raised position, chocks or safety pins must be in place to secure the platform during maintenance. Follow the chocking procedure in Section 5B if chocks or safety pins are not available. Contact Presto-ECO A for the recommended parts.

1. Safety steps

- a) The unit using a power supply of 115 Volt AC must be disconnected from its power source. *Do not* work on electrical parts unless you are a qualified electrician.
- b) AC 3 phase or high voltage units must have the power disconnected via standard lock out, tag out procedures

prior to servicing. *Do not* move the unit in an up or down motion while performing maintenance.

c) For performing any maintenance the unit must be fully secured according to Section 5B. *Do not* remove hydraulic lines unless the tilter has been lowered to its fully secured position. This should be verified several times by pushing the down button on the switch.

d) When removing hydraulic hoses, crack the fittings slowly to be sure that any hydraulic pressure that may be residual is released.

2. Inspect the following:

- a) Check the oil level and add oil if necessary according to the instructions on the hydraulic chart and schematic.
- b) Check the bolts on the pivot bar that holds the tilt platform in place, if loose tighten.
- c) Check hydraulic lines for damage or leaking. Replace if damaged.
- d) Check for oil spots or leaks around fitting and tighten.
- e) Check wiring for damage. Replace immediately if any signs of wear are evident.
- f) Bearings on all lifts are permanently lubricated. (*Do not* lubricate bearings.) Replace if worn.

B. TROUBLESHOOTING MAINTENANCE

All servicing should be done by qualified personnel who should have read and understood all of the information provided in the Operating, Installation and Maintenance sections in this manual.

1. Tilt will not move.

- a) For the 115 volt and 3 phase AC units:
 - Check the power switch, fuses and overload associated with its electrical circuits.
 - Check voltage at motor; motor may have failed.

2. Operational noises (tilter is very noisy)

- a) Tilter may be overloaded or jammed. Check load weights and obstructions.
- b) For 115 volt AC motor, check voltage at terminal. May have low voltage.
- c) Oil shortage, reservoir low or oil line failure. Repair or replace.
- d) Down valve open, check wiring. Replace if necessary.

3. Motor overheats:

- a) Excessive cycling (15 cycles per hour maximum). Check actual time in use.
- b) Low voltage-check voltage of 120 volt motors.
- c) Oil starvation-check filter on the pump by removing the coil stem from the pump. **Note:** *do not* overtighten the stem when reinstalling.

4. Tilter operating slowly:

a) Up cycle:

- Oil starvation—check suction strainer in reservoir.

Oil viscosity—oil is too heavy or too thin.

Air in cylinder—cycle tilter with no load 2 or 3 times and hold down the up button for 10 seconds after bottoming out on each cycle.

b) Down cycle:

- Down valve dirty—remove and clean. Check oil condition; replace if dirty. **Note:** *do not* overtighten the stem when reinstalling.
- Pinched hydraulic lines.
- Oil viscosity is too heavy.

5. Tilter raises, then fully lowers without power:

- a) Down valve filter is dirty. Remove and clean. **Note:** *do not* over torque when reinstalling down valve.
- b) Leaking hydraulic lines or fittings (check for telltale oil spots).
- c) Check valve in pump, may not be seating properly. Pump must be replaced.

6. Tilter will not lower when energized:

- a) Down solenoid faulty. Check voltage of coil. Check continuity of coil (could be burnt out).
- b) Raise the lift to its maximum height.
- c) Using only the chock assembly provided, place the square tubing in the wheel tray sideways and adjacent to the welded long lifting eye nut.
- d) Insert the pin which is secured to the lift through the holes provided in the wheel tray. Be sure the pin enters both holes and through the center of the tubing.
- e) Lower the lift until the wheels come in contact with the chock and hold the “down” button for another 2 seconds.
- f) Raise lift, remove and replace chock to its straight position.

Figure 1: Hydraulic Schematic

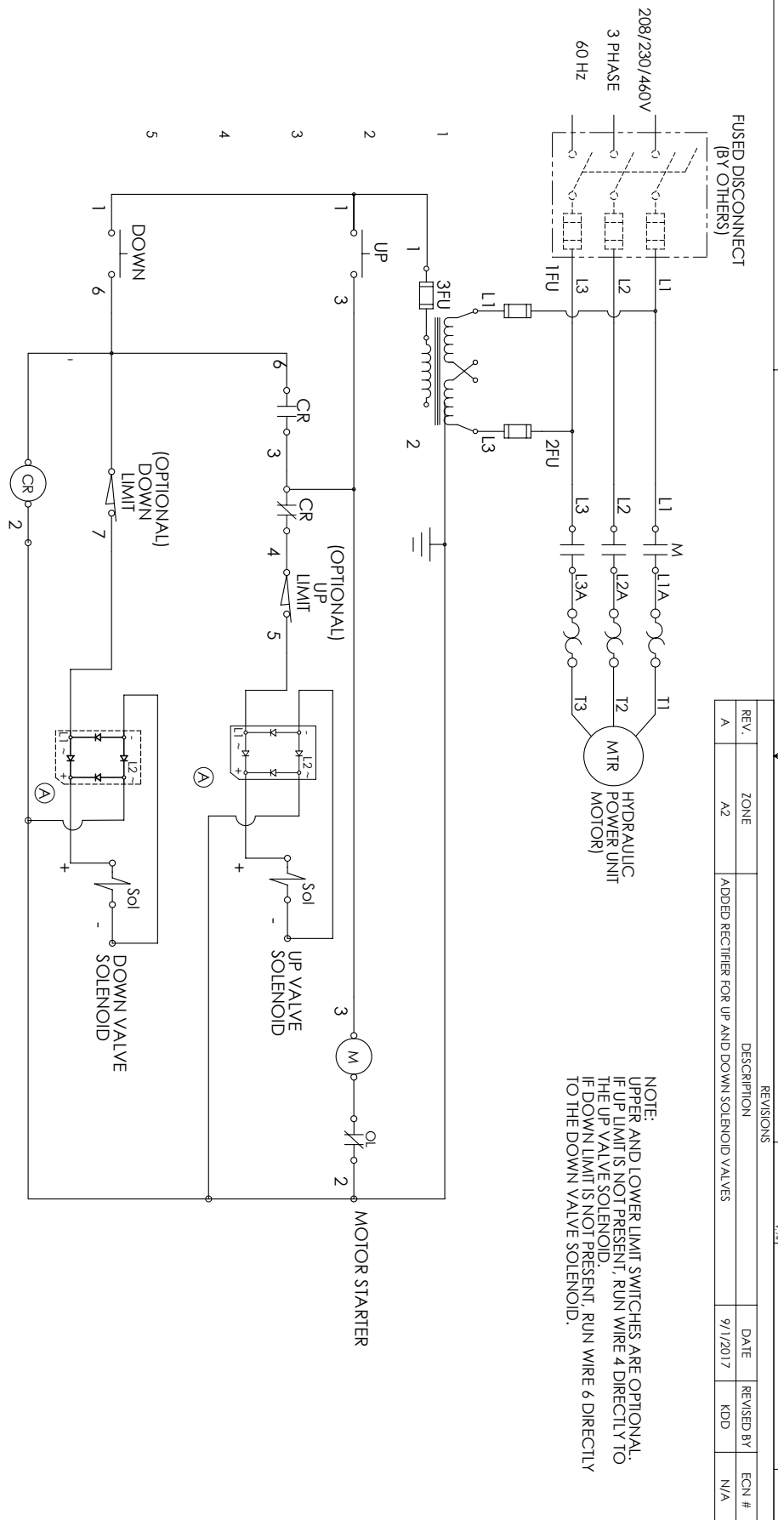

REV. A		ZONE A2		DESCRIPTION		DATE	REVISOR	ECN #
				ADDED RECTIFIER FOR UP AND DOWN SOLENOID VALVES		9/1/2017	KDD	N/A

NOTE:
 UPPER AND LOWER LIMIT SWITCHES ARE OPTIONAL.
 IF UP LIMIT IS NOT PRESENT, RUN WIRE 4 DIRECTLY TO THE UP VALVE SOLENOID.
 IF DOWN LIMIT IS NOT PRESENT, RUN WIRE 6 DIRECTLY TO THE DOWN VALVE SOLENOID.

Figure 3: Electrical Schematic Pump Unit Single Phase 115 Volts AC

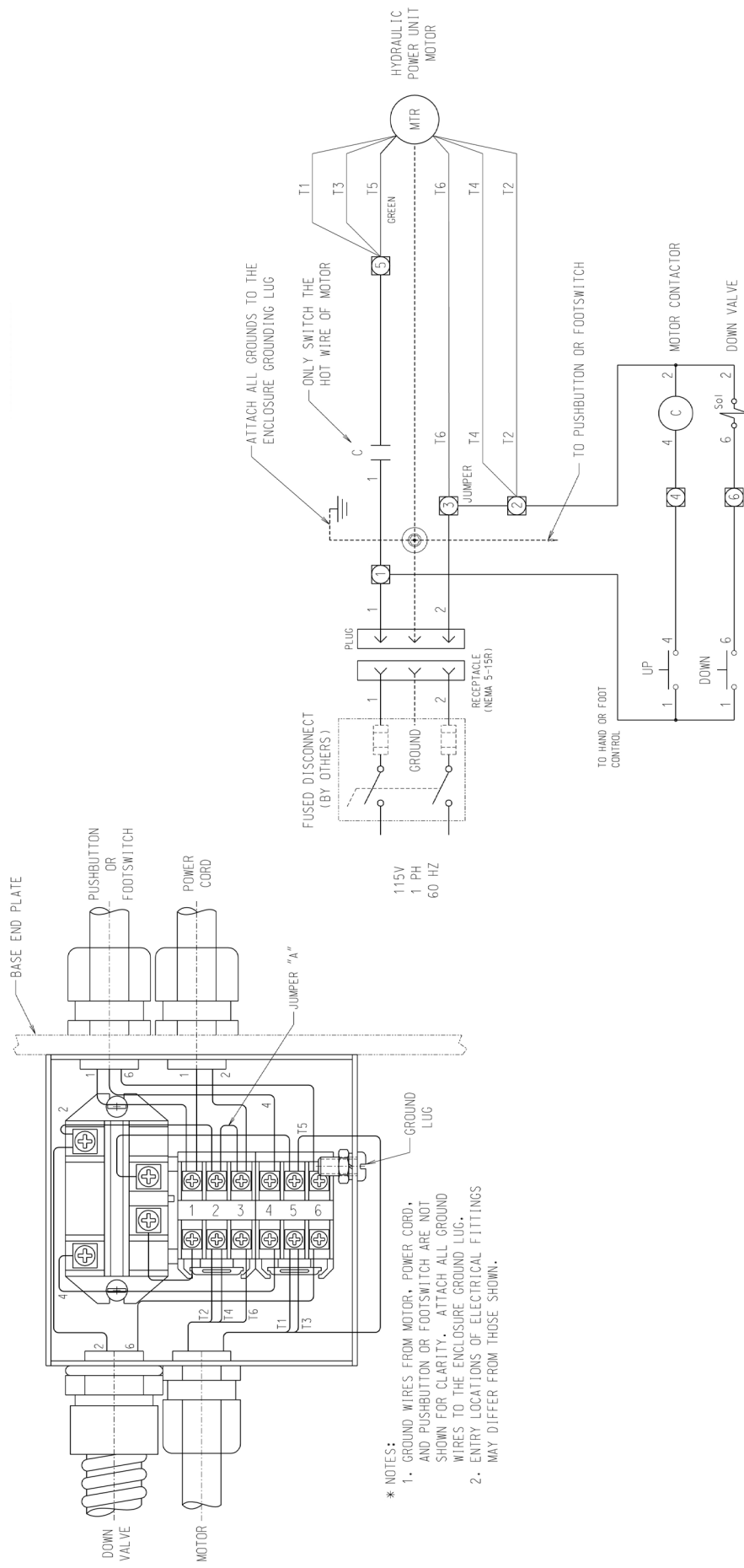

Figure 4: Electrical Schematic Pump Unit 1 Phase 208, 240 Volts AC

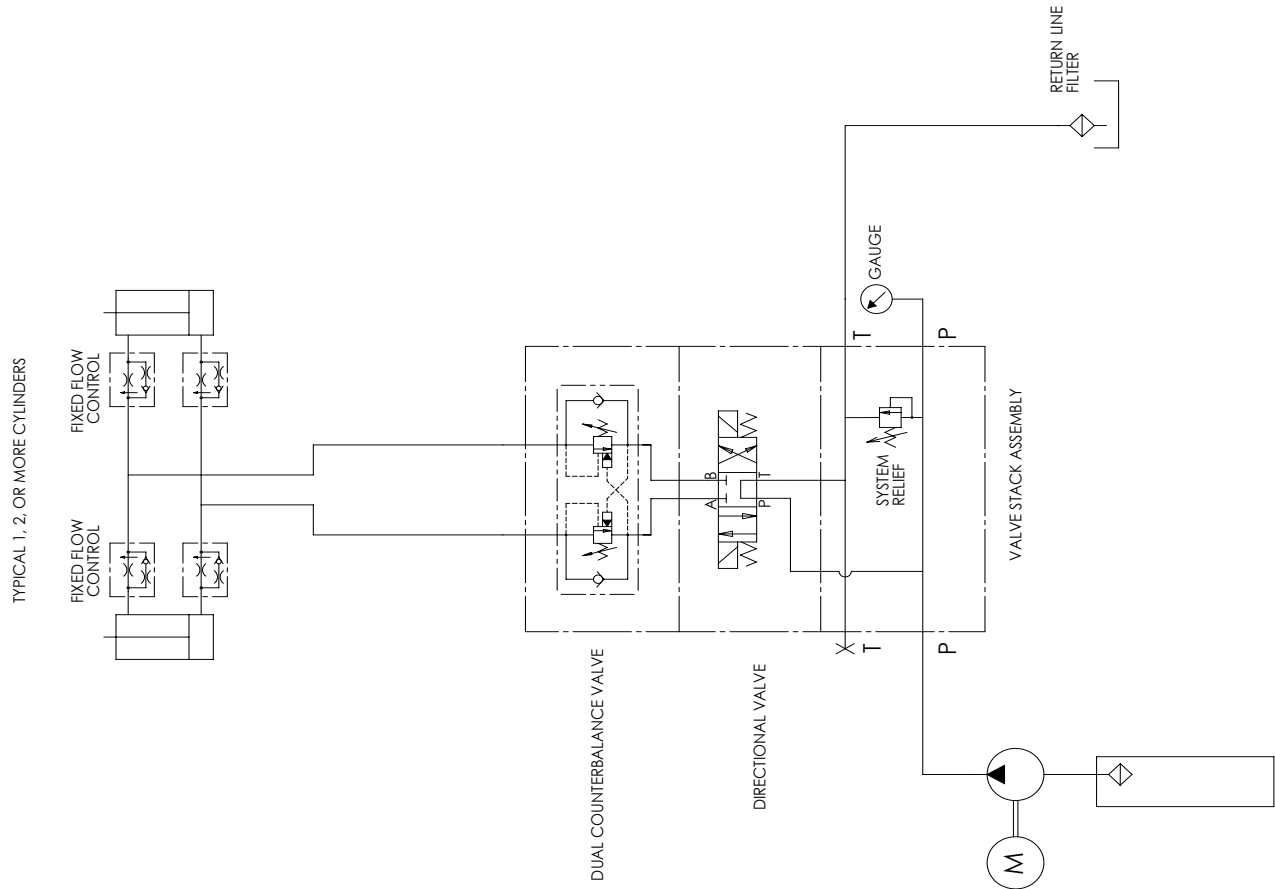

Table 1 – Hydraulic Oil Specifications

If the lift will be used at normal ambient temperatures, Presto-ECO Lifts supplies the unit with Conoco Super Hydraulic 32 oil. This may be replaced by any other good quality oil with 150 SSU at 100° F and rust and oxidation inhibitors and anti-wear properties.

If the lift will be used at ambient temperatures below 0°F, use aircraft hydraulic oil. Use Type 15 aircraft hydraulic oil.

The following are equivalent to Conoco Super Hydraulic 32:

TYPE	MANUFACTURER
AW32	CITGO
DTE 24	EXXON/MOBIL
NUTO H32	EXXON/MOBIL
AMOCO AW32	CHEVRON (AMOCO CO.)

CAUTION!

It is very important to keep the hydraulic oil free of dirt, dust, metal chips, water, and other contamination. Most of the problems with hydraulic systems are caused by contamination in the oil.

Figure 5: Labels and Locations

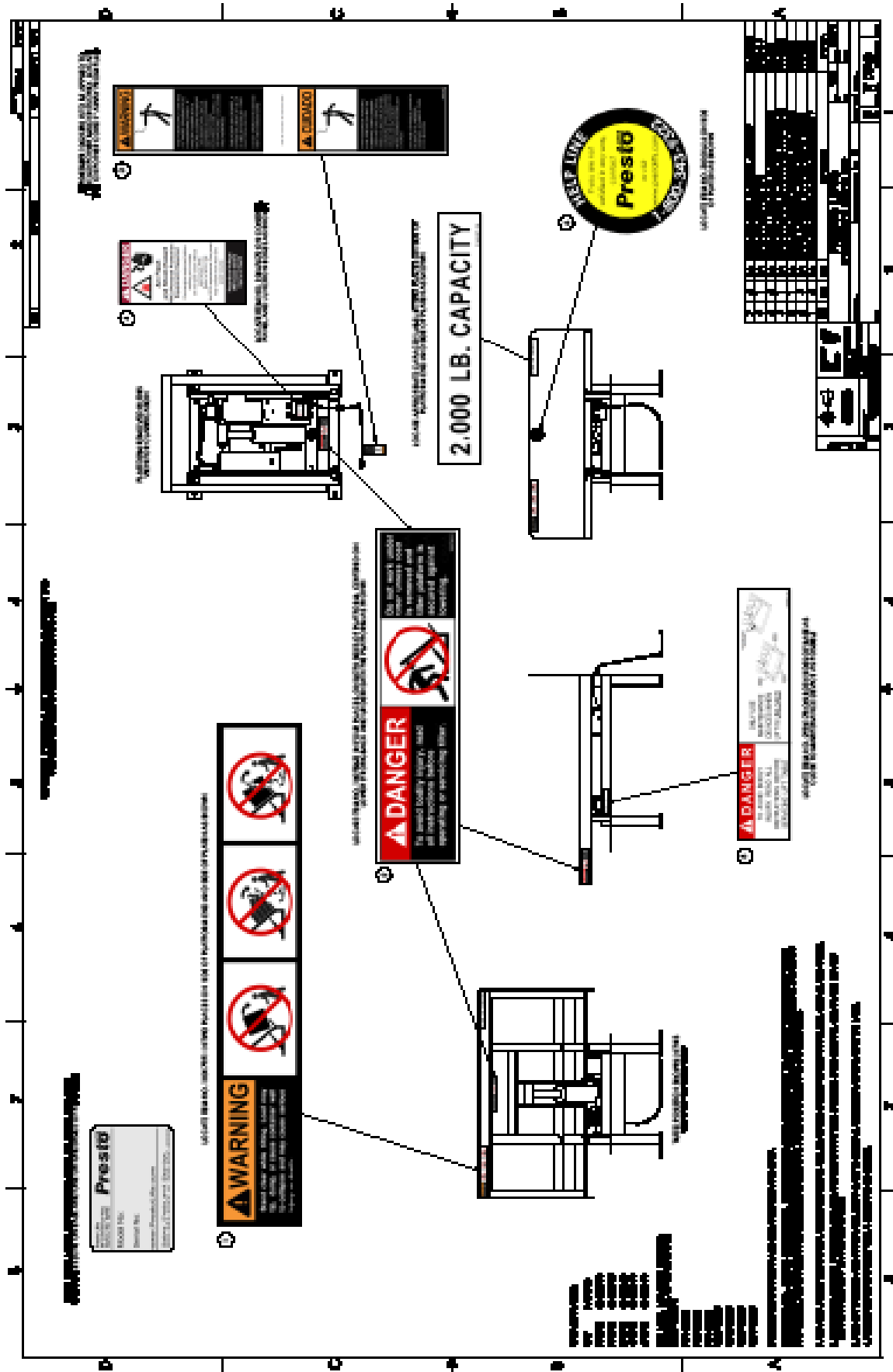

PARTS

Standard parts may be returned with a 20% restocking fee or \$35.00 net, whichever is greater. Modified or custom-engineered parts are not returnable. Unfortunately, due to potentially concealed damage, all sales of electrical assemblies are final.

QUALITY ISSUES

Should you feel there is a quality problem, please contact the seller to ask questions and gather information on how to rectify the issue. Presto-ECO Lift reserves the right to determine potential credits, as a result of factory defects, based on its inspection of the merchandise.

GENERAL

All products shipped from our factory have passed Quality Assurance inspection and testing. The carrier of choice has signed for, and accepted the product in new working condition. The customer should inspect to ensure it is not received damaged, has no concealed damage or is not incomplete. Parts orders are determined to be complete based upon Presto-ECO inspection sheets and carrier shipping weights.

Ordering Replacement Parts

Presto-ECOALifts has carefully chosen the components in your unit to be the best available for the purpose. Replacement parts should be identical to the original equipment. Presto-ECOALifts will not be responsible for equipment failures resulting from the use of incorrect replacement parts or from unauthorized modifications to the unit.

Presto-ECOALifts can supply all replacement parts for your lift. With your order, please include the model number and the serial number of the unit. You can find these numbers on the name plate. This plate is located within the scissors mechanism.

To order replacement parts, please call the Presto-ECOALifts Parts Department. Parts are shipped subject to the following terms:

- FOB factory
- Returns only with the approval of our parts department.
- Credit cards preferred (except parts covered by warranty).
- Freight collect for truck (except parts covered by warranty).
- Freight – prepaid and invoice for small parcel shipments (except parts covered by warranty).
- The warranty for repair parts is 30 days from date of shipment.

Parts replaced under warranty are on a “charge-credit” basis. We will invoice you when we ship the replacement part, then credit you when you return the worn or damaged part, and we verify that it is covered by our warranty. Labor is not covered under warranty for Parts orders.

Note: Part orders are subject to a \$50 minimum charge.

Presto-ECOALifts Parts Department

50 Commerce Way, Norton, MA 02766

Telephone: 800-343-9322

FAX: 888-788-6496

Email: service@PrestoLifts.com

www.PrestoLifts.com

www.ECOALifts.com

Presto-ECO Lifts Limited Warranty Policy

Presto-ECO Lifts warrants all of its products against defects in the welded structural frame and, if applicable, scissor legs from faulty material and workmanship for a period of five years from the date of invoice.

All other components have a limited warranty against defects in faulty material and workmanship for a two year period from the date of invoice date of invoice and 30 day limited warranty on labor. Please note that prior authorization from Presto-ECO Lifts is required on all warranty work.

There are no implied warranties of any kind, more specifically, there are no warranties of merchantability or fitness for any particular purpose. Presto-ECO Lifts' sole warranty shall be as set forth in this limited warranty.

Presto-ECO Lifts will elect to repair or replace a defective component without charge, if any components should become defective within the limited warranty period. Proof of purchase is required for warranty. The charge for shipping the defective component is the responsibility of the buyer and must be accompanied with an RMA number. The shipping charge to return the component to the buyer is the responsibility of Presto-ECO Lifts.

This limited warranty does not cover labor expense for removal or reinstallation of components after thirty days. This limited warranty shall not cover, among other things: damages resulting from foreign matter or water, failure to provide reasonable and necessary maintenance, and if applicable, use of product while charger is plugged into an AC outlet, or failure to follow operating instructions. The limited warranty is not valid for damage resulting from negligence, accident, unreasonable use, abuse or misuse, exceeding data plate capacities or altering the product without Presto-ECO Lifts authorization.

Presto-ECO Lifts expressly disclaims and excludes any liability for consequential, incidental, indirect or punitive damages or financial loss to people or property resulting from any breach of warranty or the operation or failure of this product.

Presto-ECO Lifts makes no representation that this product complies with local, state, or federal safety/product standards codes. Should this product fail to comply in any way with those codes, it shall not be considered a defect of materials or workmanship. Presto-ECO Lifts shall not be held liable for any damages resulting from noncompliance. It is the dealer's responsibility to exercise this limited warranty. This limited warranty is provided to the original purchaser (defined as the original end user) and is nontransferable. This constitutes the complete and final agreement involving Presto-ECO Lifts limited warranty obligations for products.