



Presto ^{LIFTS™}
worldwide material handling
and ergonomic solutions

PT & PTS Series Portable Container Tilters

Installation, Operation and Service Manual

Model Number _____

Serial # _____

Date placed in service _____

**IMPORTANT: READ CAREFULLY
BEFORE INSTALLING OR OPERATING LIFT**

Part orders are subject to a \$50 minimum charge.

JUNE 2018



This manual was current at the time of printing. To obtain the latest, most updated version, please contact Presto Lifts Customer Service Department or go to our website: www.PrestoLifts.com -- you will find a complete list of current owner's manuals to print.

CONTENTS

SECTION 1:	
INTRODUCTION	4
RESPONSIBILITY OF OWNERS AND USERS.....	5
SAFETY ALERT SYMBOLS AND SIGNAL WORDS	6
SECTION 2:	
SAFETY.....	7
SECTION 3:	
INSTALLATION	8
A. Installing.....	8
B. Electrical.....	8
C. Hydraulic.....	9
D. Testing the Tilter with No Load	9
SECTION 4:	
OPERATION	10
A. Method of Operation.....	10
B. Operation Procedures	11
SECTION 5:	
MAINTENANCE	11
A. Routine Maintenance	11
B. Troubleshooting Maintenance.....	12
SECTION 6:	
SERVICE	13
A. Replacing Cylinder Seals.....	13
B. Replacing Rigid & Swivel Wheels.....	13
C. Ordering Replacement Parts.....	14
LIST OF FIGURES:	
Figure 1 Loading and Operational Diagram	10
Figure 2 Pinch Point Diagram	10
Figure 3 Wiring Diagram 12V DC.....	15
Figure 4 Hydraulic Schematic	15
Figure 5 Component Identification - DC Units	16
Figure 6 Labels and Locations.....	17
RESTOCKING POLICY	18
RETURN GOODS AUTHORIZATION (RMA) PROCEDURES.....	19
ORDERING REPLACEMENT PARTS	20
WARRANTY	21

SECTION 1

INTRODUCTION

The PT & PTS Series Container Tilters are designed for lifting, tilting and positioning a wide variety of loads. Each tilter has front, rigid wheels and large rear swivel casters, allowing the tilter to be easily positioned under the container to be tilted. A floor lock is provided for maintaining the tilter in position during loading and unloading.

This manual provides all the information for the safe and proper installation, operation and maintenance of Presto Lifts PT & PTS Series Portable Container Tilters. It is important that this manual be read by all personnel involved with the installation, maintenance or operation of the tilter. WHERE UNIQUE SITUATIONS ARISE, WHICH ARE NOT COVERED IN THIS MANUAL, CALL PRESTO LIFTS, INC. FOR FURTHER INSTRUCTIONS. Additional manuals are available upon request.

The Container Tilter has a nameplate, which provides the load capacity rating, serial number and model identification. Please refer to these numbers when ordering parts or requesting further information.

The PT & PTS Series Container Tilter is designed for in-plant, non-hazardous location use only.

Responsibility of Owners and Users

Inspection and Maintenance

The device shall be inspected and maintained in proper working order in accordance with Presto's owner's manual.

Removal from Service

Any device not in safe operating condition such as, but not limited to, excessive leakage, missing rollers, pins, or fasteners, any bent or cracked structural members, cut or frayed electric, hydraulic, or pneumatic lines, damaged or malfunctioning controls or safety devices, etc. shall be removed from service until it is repaired to the original manufacturer's standards.

Repairs

All repairs shall be made by qualified personnel in conformance with Presto's instructions.

Operators

Only trained personnel and authorized personnel shall be permitted to operate PowerStak.

Before Operation

Before using the device, the operator shall have:

- Read and/or had explained, and understood, the manufacturer's operating instructions and safety rules.
- Inspected the device for proper operation and condition. Any suspect item shall be carefully examined and a determination made by a qualified person as to whether it constitutes a hazard. All items not in conformance with Presto's specification shall be corrected before further use of the PowerStak.

During Operation

The device shall only be used in accordance with this owner's manual.

- Do not overload.
- Ensure that all safety devices are operational and in place.

Modifications or Alterations

Modifications or alterations to any Presto industrial positioning equipment shall be made only with written permission from Presto.

SAFETY ALERT SYMBOLS AND SIGNAL WORDS

The safety of all persons operating, maintaining, repairing, or in the vicinity of this equipment is of paramount concern. This is a powerful machine with moving parts, and is capable of causing personal injury if proper precautions are not taken. Therefore, throughout this manual, certain hazards have been identified which may occur in the use of the machine, and there are appropriate instructions or precautions which should be taken to avoid these hazards. In some cases, there are consequences which may occur if instructions or precautions are not followed. Below are the symbols and signal words along with their definitions referenced from ANSI Z535.4 - Product Safety Signs and Labels.

Safety Alert Symbols

These are the safety alert symbols.. They are used to alert you to potential physical injury hazards. Obey all safety messages that follow this symbol to avoid possible injury or death.



For use with DANGER signal word
(Red Background)



For use with WARNING signal word
(Orange Background)



For use with CAUTION signal word
(Yellow Background)

Signal Words

The meaning of different signal words as defined by ANSI Standard Z535.4 indicates the relative seriousness of the hazardous situation.



(Red Background)

DANGER indicates a hazardous situation which, if not avoided, will result in death or serious injury.



(Orange Background)

WARNING indicates a hazardous situation which, if not avoided, could result in death or serious injury.



(Yellow Background)

CAUTION, used with the safety alert symbol, indicates a hazardous situation which, if not avoided, could result in minor or moderate injury.



(Blue Background)

NOTICE is used to address practices not related to personal injury.



(Green Background)

SAFETY INSTRUCTIONS (or equivalent) signs indicate safety-related instructions or procedures.

SECTION 2

SAFETY

The safety of all persons installing, using, servicing, or working near the unit is of paramount concern to Presto Lifts. The tilter is a powerful machine with moving parts, and is **capable of causing personal injury if proper precautions are not taken**. Therefore, throughout this manual, Presto Lifts has identified certain hazards, which may occur in the use of the unit, and provided appropriate **instructions** or precautions that should be taken to avoid these hazards. In some cases, Presto Lifts' has also pointed out the **consequences** that may occur if Presto Lifts' instructions or precautions are not followed. Presto Lifts uses the following nationally recognized system for identifying the severity of the hazards associated with its products:

 **DANGER** – Immediate hazard that will result in severe personal injury or death.

 **WARNING** – Hazard or unsafe practice, that could result in severe personal injury or death.

 **CAUTION** – Hazard or unsafe practice, that could result in minor personal injury or property damage.

In the interest of safety, please read the entire manual carefully. You must understand the material in this manual before you install, use, or service the unit. If you have any question about any of the instructions in this manual, please contact Presto Lifts Inc. at 1-800-343-9322.

⚠ WARNING

- Do not perform any repair work on tilters with the forks in a raised position.
- All personnel must stand clear of the tilter when container is being tilted.
- Do not put hand or feet under the forks or the container while lowering or raising the tilter.
- Do not work under the forks or under the container positioned on the forks.
- Do not stand, sit or climb on the forks of the tilter, either during or after operation.
- Do not roll the tilter on soft, uneven or unstable surfaces with a load.
- Do not exceed load capacity.
- Do not try to raise or lower the tilter while moving the tilter.

Place load in center of the forks and against the tilter platform. Be sure that the load is secured properly.

SECTION 3 INSTALLATION

Upon receipt of the Portable Container Tilters, inspect the equipment completely to determine if there is any shipment damage and that the tilter is complete. Do not use the tilter if there appears to be any damage. With the tilter in a collapsed position or the forks in a down position, check the following by carefully removing the battery housing cover and the shield that protects the top of the power pack area.

1. Check for signs of damage, especially to the electrical and hydraulic components.
2. Check all connections for tightness. Also check for visible hydraulic liquid around the connections.
3. Check for any physical damage to the frame or wheels.
4. Inspect the forks for damage, either twisted or bent.

⚠ CAUTION

Do not operate the tilter before performing the installation procedures specified in section B, C, D and E. Severe damage to the tilter may occur.

A. INSTALLING:

Read all of the instructions prior to starting or connecting the tilter.

1. Working Area

- a) Make sure that the floor and the operation area is flat, stable, relatively smooth and free from dirt, obstacles and surface defects.
- b) Move the empty tilter to exact operating area ensuring that there are no change to obstacles due to components or equipment in the general area.

⚠ CAUTION

Do not operate the unit out of doors or any place where it could get wet. If any of the electrical components get wet, the worker may receive a shock. The electrical components may also fail. Make sure that all four (4) wheels of the tilter are in contact with the floor.

⚠ WARNING

If the unit is mounted in an unstable area it may tip over when in use. To avoid this problem always use the unit on a solid and stable surface.

B. ELECTRICAL:

1. DC Motor Models

- a) Motors on the Portable container Tilters are special, intermittent duty motors with high pull up torques. These motors require heavier duty controls than standard motors. A DC/ 1HP motor powers the standard PT & PTS units. The battery source is 12 volt 60 AMP gel cell battery for the 2,000 lb. tilter, and a 72 AMP gel cell battery for the 4,000 lb. tilter. Schematics are provided at the end of this manual for the connections of the dc operated tilters.
- b) The tilters with the DC motors are shipped with the positive terminal of the battery disconnected. Connect the positive terminal being sure not to touch any of the grounded parts while doing so with the screwdriver or the wrench. (See figure 3 for electrical schematic.)

2. AC Motor Models

The optional motor available is a 115-volt AC motor, which is a special, intermittent duty motor with high pull up torques. These motors require heavier duty electrical controls and outlets than standard motors.

⚠ CAUTION

All wiring must conform to local codes and must be performed by licensed electricians. The 1 horsepower AC motor requires a 115 volt 20 AMP fused outlet.

⚠ WARNING

Do not tamper with or remove the cover of the electrical junction box. Only authorized, qualified personnel should service the electrical system.

Motor direction is critical. This motor has been wired according to its schematic and should not be tampered with as it may lead to pump or motor failure.

C. HYDRAULIC:

1. Before using the tilter, check the hydraulic oil level by removing the solid plug from the reservoir, which is located at the upper end of the left support. Remove the plug, check for oil and add oil if necessary. The level should be approximately 1” below the surface. Replace the plug with the vent plug provided; if the vented plug is not installed you may damage the pump.
2. Use hydraulic oil only in the tilter. The tilter has been supplied with a Conoco 32. When adding fluid, use only the recommended oils or equivalent.

⚠ CAUTION

The Portable Container Tilters are designed for

normal factory environments. Where below freezing temperatures sometimes exist, special fluids must be used. Contact Presto Lifts Inc. for further information when freezing conditions exists.

⚠ WARNING

Do not use automotive hydraulic brake or transmission fluids, they will damage and pose a serious fire hazard.

D. TESTING THE TILTER WITH NO LOAD:

Before operating the tilter, read and understand this section.

1. Before testing the tilter, clear the area of any loose material. Be sure the tilter has no obstructions above it or on any side. Using the controls provided, briefly operate the tilter (5-10 seconds). If the tilter begins to rise with a humming sound and functions properly, continue to the full upright position.

⚠ CAUTION

If the tilter does not rise immediately, or there is any operational problem, stop it immediately. Before continuing, check the rotation of the pump and motor and the voltage at motor terminals, again

If the lift will be used at normal ambient temperatures, Presto Lifts supplies the unit with CONOCO 32 oil. This may be replaced by any other good quality oil with 150 SSU at 100° F and rust and oxidation inhibitors and anti-wear properties.

If the lift will be used at ambient temperatures below 0°F, use aircraft grade hydraulic oil. Type 15 aircraft hydraulic oil is recommended.

The following are equivalent to Conoco 32

TYPE	MANUFACTURER
DTE 24	EXXON/MOBIL
NUTO H32	EXXON/MOBIL
AMOCO AW32	CHEVRON (AMOCOCO.)
AW32	CITGO

⚠ CAUTION

It is very important to keep the hydraulic oil free of dirt, dust, metal chips, water, and other contamination. Most of the problems with hydraulic systems are caused by contamination in the oil.

briefly operate the tilter. If the tilter does not move smoothly with the humming sound, stop and review the procedures in the section on troubleshooting.

- After raising the tilter completely, lower the tilter completely. It should move slowly and smoothly without a humming sound. If the tilter operates properly, raise and lower the tilter and stop at different levels in order to familiarize yourself with the tilter's operations and movements.

WARNING

As the container tilter platform and forks move up and down, pinch points are created at locations near the base of the base of the frame. While operating the tilter the operator should be standing behind the tilter located near the battery and power pack area, in that way, the operator's arms, legs or clothing will not be caught in the moving parts. During operations the operator should avoid the pinch point areas, which are located on either side of the tilter. See the diagram pointing out the particular pinch points (figure 1).

SECTION 4 OPERATION

A. METHOD OF OPERATION:

All Portable Container Tilters are provided with a special hydraulic relief valve, which is factory preset to the maximum safe capacity of the container tilter (see the nameplate attached to the tilter). Activating and holding the up switch will energize the motor. The motor is attached to a positive displacement pump, which draws hydraulic fluid from the reservoir and transfers it under pressure to the cylinder. This forces the piston forward and the forks to rise in a ninety-degree arc. Releasing the up button will stop the tilter. A check valve between the pump and piston holds the forks in position. Depressing and holding the down button of the switch will energize a solenoid, which allows the oil from the cylinder to return to the reservoir through a preset flow control. This allows the tilter to lower smoothly and at a controlled speed.

CAUTION

Do not maintain the up button on the switch energized if the tilter does not move or has not reached its upper limit. This may cause damage to the motor, pump and controls.

**FIGURE 1:
Loading and Operational Diagram**

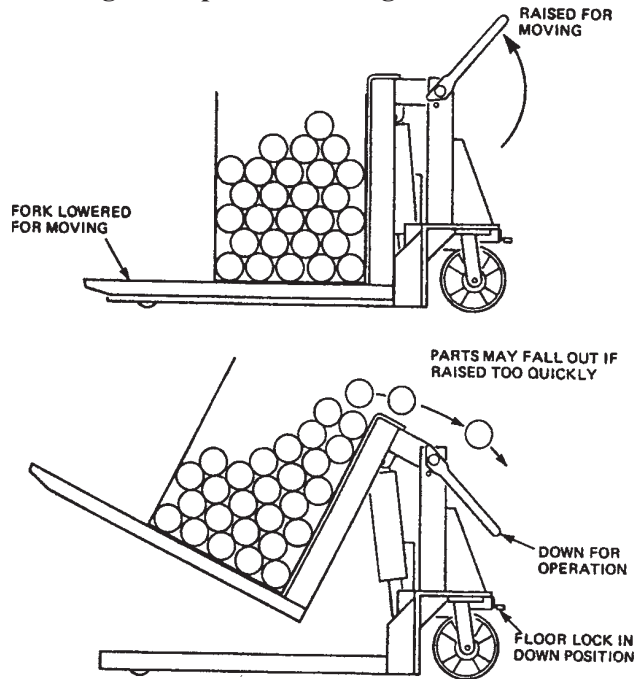
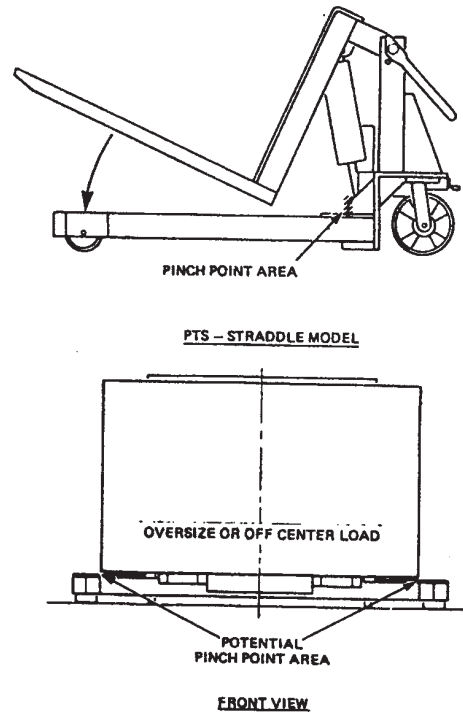

FIGURE 2: Pinch Point



B. OPERATION PROCEDURES:

In order to operate the tilter, follow these operating procedures:

1. Read and understand all the instructions before operating, if the tilter has modifications or accessories, read and understand their functions.
2. Load the tilter correctly (figure 1.) Refer to the attached nameplate for load capacity information.
 - a) Do not load the tilter while it is running.
 - b) Do not exceed the maximum rated load (note that load capacity is on the nameplate of the tilter).
 - c) Engage floor lock prior to loading tilter.
 - d) Place load in the center and at the very back of the forks.
 - e) If the load is unstable or may become unstable, fasten it into position.
3. Operate the Tilter
 - a) To raise the tilter, press and hold the up button on the switch.
 - b) To lower the tilter, press the down button on switch.
 - c) Release the button to stop the tilter in either direction.
4. Wait until the tilter has come to a complete stop before loading or unloading.
5. Stand clear of the tilter when operating in order to avoid injury.

⚠ WARNING

- a) Do not stand, sit or climb onto the tilter.
- b) Do not load or unload a moving tilter.
- c) If the tilter fails to move or exhibits strange movements or sounds, stop immediately. Do not operate the tilter until it has been checked and repaired.
- d) Obey all warning labels.

6. Moving the unit

- a) When moving an empty tilter be sure the forks are in a completely lowered position.
 - i) Release the floor lock.
 - ii) Set your push handle into position (see figure 1). The figure shows the handle in its raised and lowered position. The handle is controlled by a stop pin to prohibit travel beyond a safe pushing point.
 - iii) With the handle in an up position, the tilter can now be carefully moved forward. When pulling the unit keep your feet clear of the caster wheels.

- b) When moving a loaded tilter, procedures are as follows: lower the tilter forks until the container legs or base is $\frac{1}{2}$ " inch to 1" inch above the ground, then proceed as previously discussed with an empty tilter.

⚠ WARNING

Do not move the unit with the fork in a raised position. Moving a raised container could cause product to fall out or cause the basket or container to become unstable, and thereby, could cause injury.

As you move the unit in a backward direction, keep your feet clear of the swivel casters. When moving a loaded tilter it would be safer for two (2) operators to direct the tilter.

SECTION 5

MAINTENANCE

Generally, the Portable Container Tilter Lift will require little maintenance. However, routine inspection and maintenance will minimize costly repairs or hazardous conditions.

⚠ WARNING

Before servicing the unit, read and understand this entire section and the section entitled Operating Instructions.

Never go under or service a tilter with a load on the forks or with the forks in a raised position. Always service the tilter in a down position.

A. ROUTINE MAINTENANCE:

1. All routine inspection maintenance should be performed monthly, and can be performed on the Portable Container Tilter Lift in a down position. Before performing any maintenance, shut the power off. In the case of the 115-volt, remove the plug from the receptacle. When servicing a battery-operated unit, disconnect the positive terminal from the battery. Remove the safety shelf cover and the battery cover from the tilter. By doing this you will make available all of the components that may require servicing.
2. Periodic maintenance checks and service:

- a) Check the oil level and add oil if necessary according to the instructions on the hydraulic schematic.
 - b) Check the snap rings on the pivot bar that holds the tilt forks in place, if damaged, replace them.
 - c) Check hydraulic lines for damage or leaking. Replace if damaged.
 - d) Check for oil spots or leaks around fittings. Trace leaks to the proper fitting and tighten.
 - e) Check wiring for damage. Replace immediately if any signs of wear are evident.
 - f) Bearings on all tilters are permanently lubricated and require no servicing. (Do not oil or grease.)
 - g) The rear swivel casters should be inspected for lubricant wear or cracks. Replace if required. Grease if needed.
 - h) Front load wheels should also be inspected for wear or cracks. Replace if damage.
3. Charging a gel cell battery:
- a) Lower lift to its full lowered position.
 - b) Remove battery cove, shield, positive and negative terminals.
 - c) Do not attempt to remove battery caps or covers.
 - d) Connect battery charger positive and negative terminal to battery with charger provided with lift.
 - e) Plug battery charger in 120-volt wall outlet.
 - f) Observe charger voltage meter. Low batteries will show 14+ volts. As batteries charge the voltage will drop to 12-13 volts.
 - g) Time to charge will depend on battery use. Generally a one-shift operation will require 4-6 hours to recharge fully.

CAUTION

- a. **Do not attempt to remove battery covers or caps.**
- b. **Wear safety glasses and gloves when charging or replacing batteries.**
- c. **Always use charger provided.**
- d. **Read charger instruction prior to charging batteries.**

WARNING

The unit using a power supply of the 115-volt AC must be disconnected from its power source. Do not work on electrical circuits unless you are a qualified electrician. DC units must have the positive cable

removed from the battery terminal. Do not move the unit while maintenance is continuing to be done.

Before performing any maintenance on the unit, it must be in a fully lowered position. Do not remove hydraulic lines unless the tilter has been lowered to its lowest down position. This should be verified several times by pushing the down button on the switch (prior to electrical disconnect).

When removing hydraulic hoses, crack the fittings slowly to be sure that any hydraulic pressure that may be residual is released.

B.TROUBLESHOOTING MAINTENANCE:

All servicing should be done by qualified personnel who should have read and understood all of the information provided in the Operating, Installation and Maintenance sections in this manual.

1. Tilt will not move up
 - a) For the 115 volt AC units:
 - i) Load is too heavy. Check weight versus nameplate rating.
 - ii) Check the power switch, fuses and overload associated with its electrical circuits.
 - iii) Check voltage at motor; motor may have failed.
 - b) For DC units:
 - i) Inspect battery voltage level for charge and recharge if necessary.
 - ii) Check terminals at the battery for corrosion or faulty connections.
 - iii) Check voltage at the motor; motor may have failed.
2. Operational noises (tilter is not moving or is very noisy when moving):
 - a) Tilter may be overloaded or jammed. Check load weights and obstructions.
 - b) For 115 volt AC motor, check voltage at terminal. Repair or replace.
 - c) Oil shortage, reservoir low or oil line failure. Repair or replace.
 - d) Down valve open, check wiring. Replace if necessary.
 - e) Air in the system causing cavitations. Check fittings and lines.
3. Motor overheats:
 - a) Excessive cycling (15 cycles per hour maximum). Check actual time in use.
 - b) Low voltage-check voltage of AC motor.

- c) Oil starvation – check filter on the pump by removing the coil stem from the pump. Note: Do not over tighten the stem when reinstalling (maximum 4 ft/lb).
4. Tilter operating slowly:
 - a) Up cycle:
 - i) Oil starvation- check filter in reservoir.
 - ii) Oil viscosity- oil is too heavy or too thin.
 - iii) Air in cylinder- cycle tilter with no load 2-3 times and hold down the up button for 10 seconds after bottoming out on each cycle.
 - b) Down Cycle:
 - i) Down valve dirty - remove and clean.
Check oil condition; replace if dirty. Note: Do not over-tighten the stem when reinstalling (maximum 4ft/lbs.).
 - ii) Pinched hydraulic lines.
 - iii) Oil viscosity is too heavy.
 5. Tilter raises, then fully lowers without power:
 - a) Down valve filter is dirty. Remove and clean. Note: Do not over torque when reinstalling down valve (maximum 4 ft./lbs).
 - b) Leaking hydraulic lines or fittings (check for telltale oil spots and tighten).
 - c) Check valve in pump, may not be seating properly. Pump must be replaced.
 6. Tilter will not lower when energized:
 - a) Down solenoid faulty. Check voltage of coil. Check continuity of coil (could be burnt out)
 - b) Down solenoid retainer nut over torque causing damage to the down valve stem. Replace.
 - c) Down valve dirty. Remove and clean.
 - d) Leaking hydraulic lines or fittings (check for telltale oil spots).
 - e) Check valve in pump -- may not be seating. Requires new pump.
- b) On DC units, remove the positive terminal from the battery.
 4. Disconnect the hydraulic hose from the cylinder and cap the line to prevent hydraulic fluid loss.
 5. Remove the cylinder pin. Note: loosen the set screws from the holding pin that has secured the cylinder in position.
 6. Lift cylinder out of tilter.

CAUTION

When disconnecting the hydraulic hose from the cylinder, crack the fittings to be sure that the residual hydraulic fluid pressure that may be in the line is released slowly. Hold the cylinder securely while removing the pin to prevent it from falling to the floor or injuring someone that is servicing it.

7. Clamp cylinder securely at the base end.
8. Completely collapse cylinder piston.
9. Push gland into the cylinder 1/8".
10. Remove retainer ring.
11. Remove piston rod, piston and gland from cylinder.
12. Remove rod nut, piston and gland.
13. Remove and replace seals and wipers.
14. Assemble piston and gland to piston rod.
15. Assemble rod nut to piston rod & torque to 100 ft./lb.
16. Lubricate piston and seals and install in cylinder.
17. Insert retainer ring.
18. Install cylinder and hydraulic lines.
19. Fill reservoir.
20. Cycle tilter 2 to 3 times with no load.
21. Recheck reservoir oil level and fill if necessary.

B. REPLACING FRONT RIGID LOAD WHEELS AND SWIVEL CASTER WHEELS:

With the tilter in its completely lowered position, raise the tilter one inch (1") using either a Johnson Bar or a crow bar and chocking the unit to maintain the wheels approximately 1/2" to 3/4" off the ground. Service one wheel at a time.

1. Unloosening the screws that hold them in position, remove the wheels and replace with new units. Note: the nut and bolt assembly has a lock washer, it is imperative that the lock washer be replaced when reinstalling.

CAUTION

Do not service more than one wheel at a time. Tilter will become unstable if more than one wheel is serviced simultaneously.

SECTION 6

SERVICE

A. REPLACING CYLINDER SEALS:

1. Lower the tilter to its lowest position and hold down switch for an additional 10 to 20 seconds.
2. Remove the steel plate and battery cover.
3. Disconnect the electrical power:
 - a) 115-volt units must have the plug removed from the receptacle.

C. ORDERING REPLACEMENT PARTS:

1. All key parts are identified and must be replaced with original equipment components.
2. Warranties will be voided where original equipment components are not used.
3. In ordering the replacement parts, be sure to include the serial number and model number of the tilter you are requesting parts for.

FIGURE 3: Wiring Diagram 12V DC

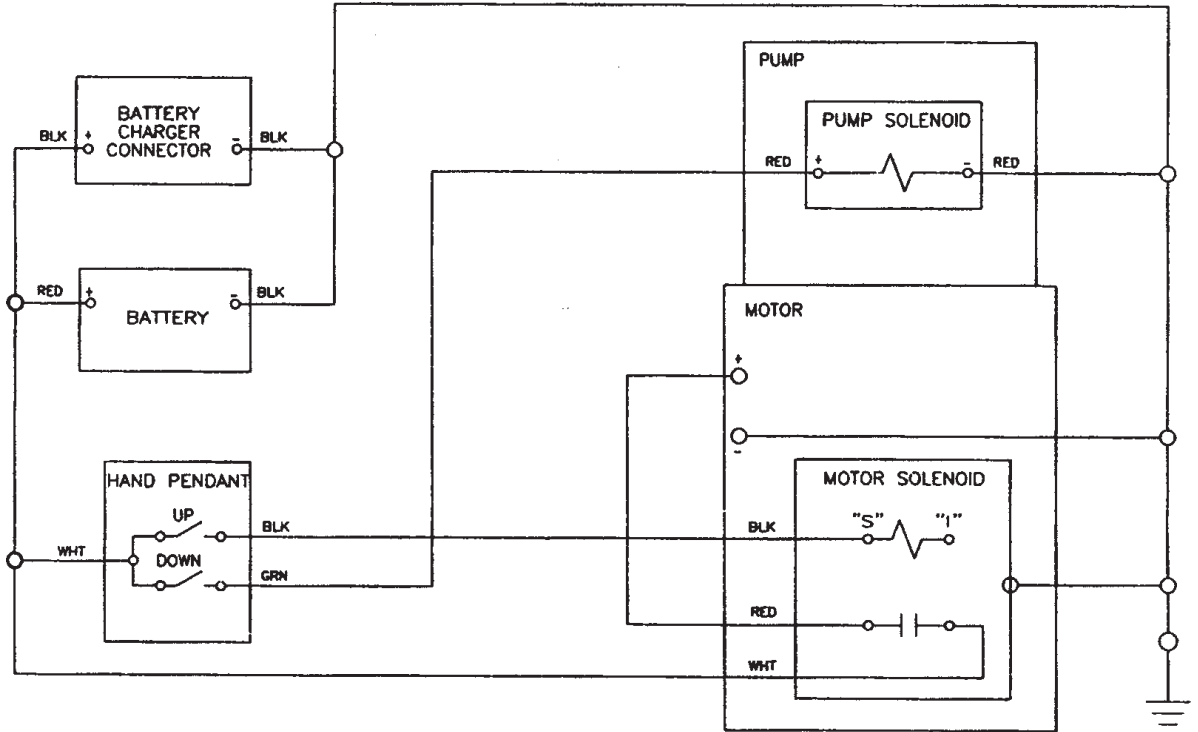

NOTE:
DO NOT CONNECT "I" CONTACT
TO ANY TERMINAL OR "GROUND"

FIGURE 4: Hydraulic Schematic

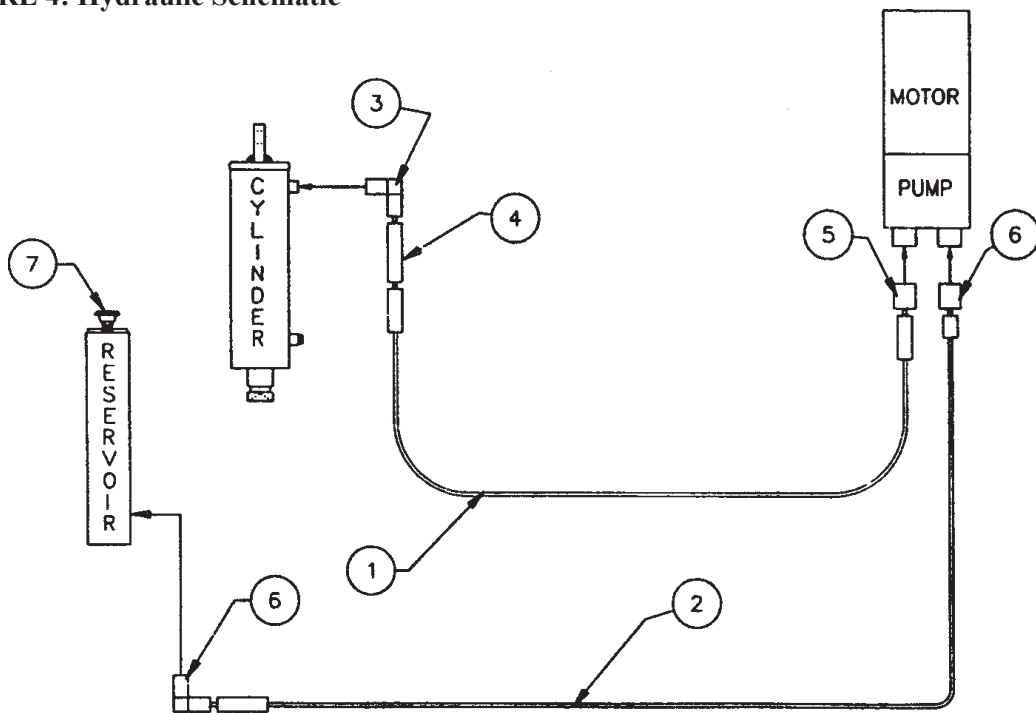
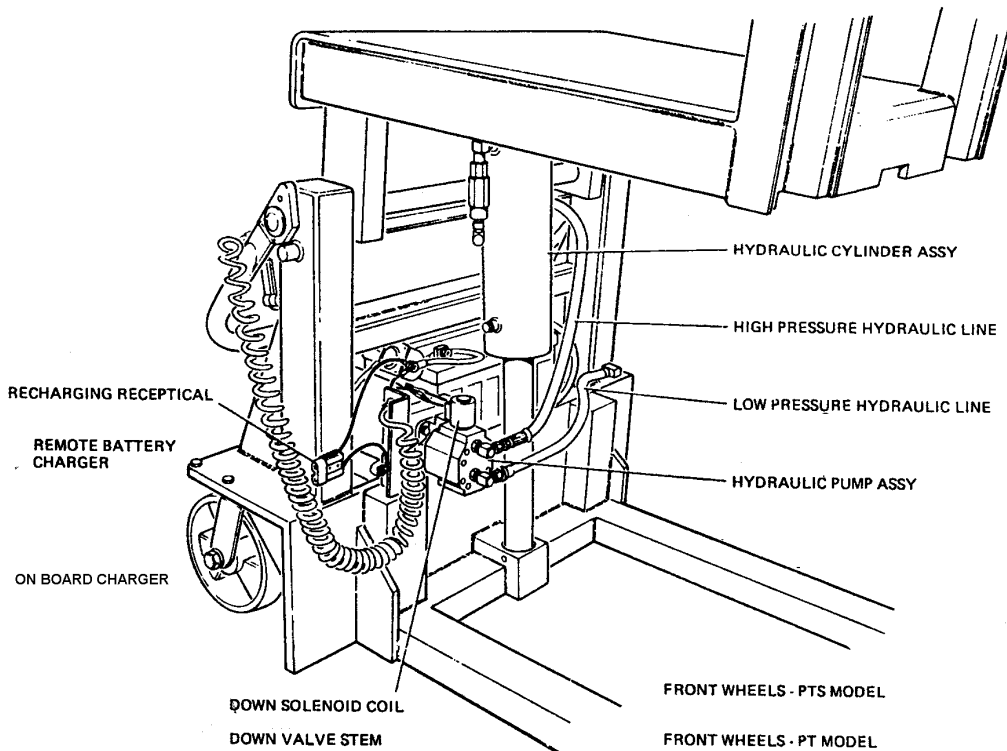
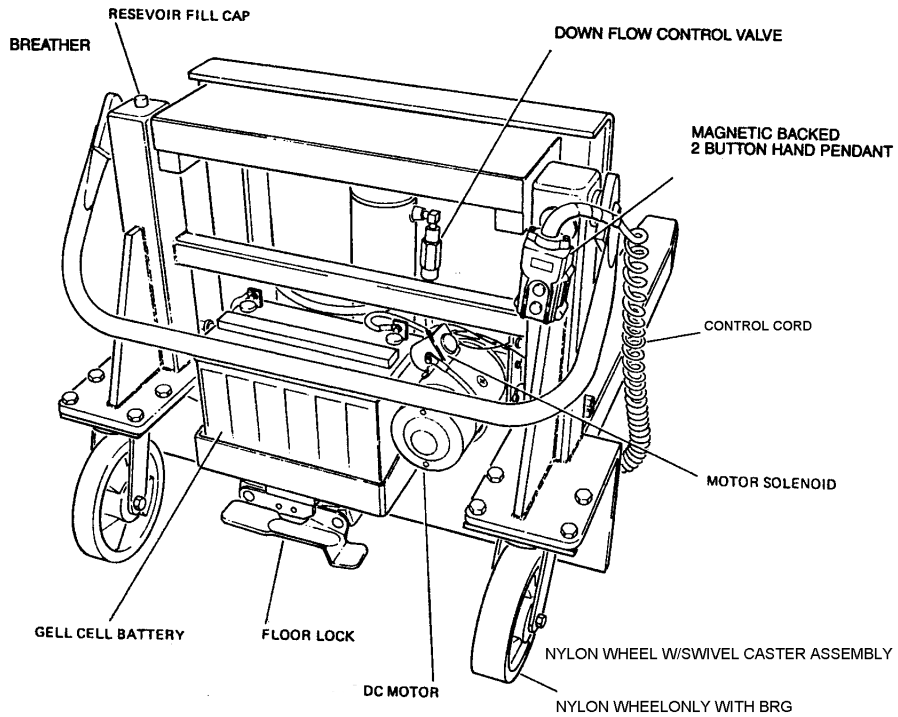
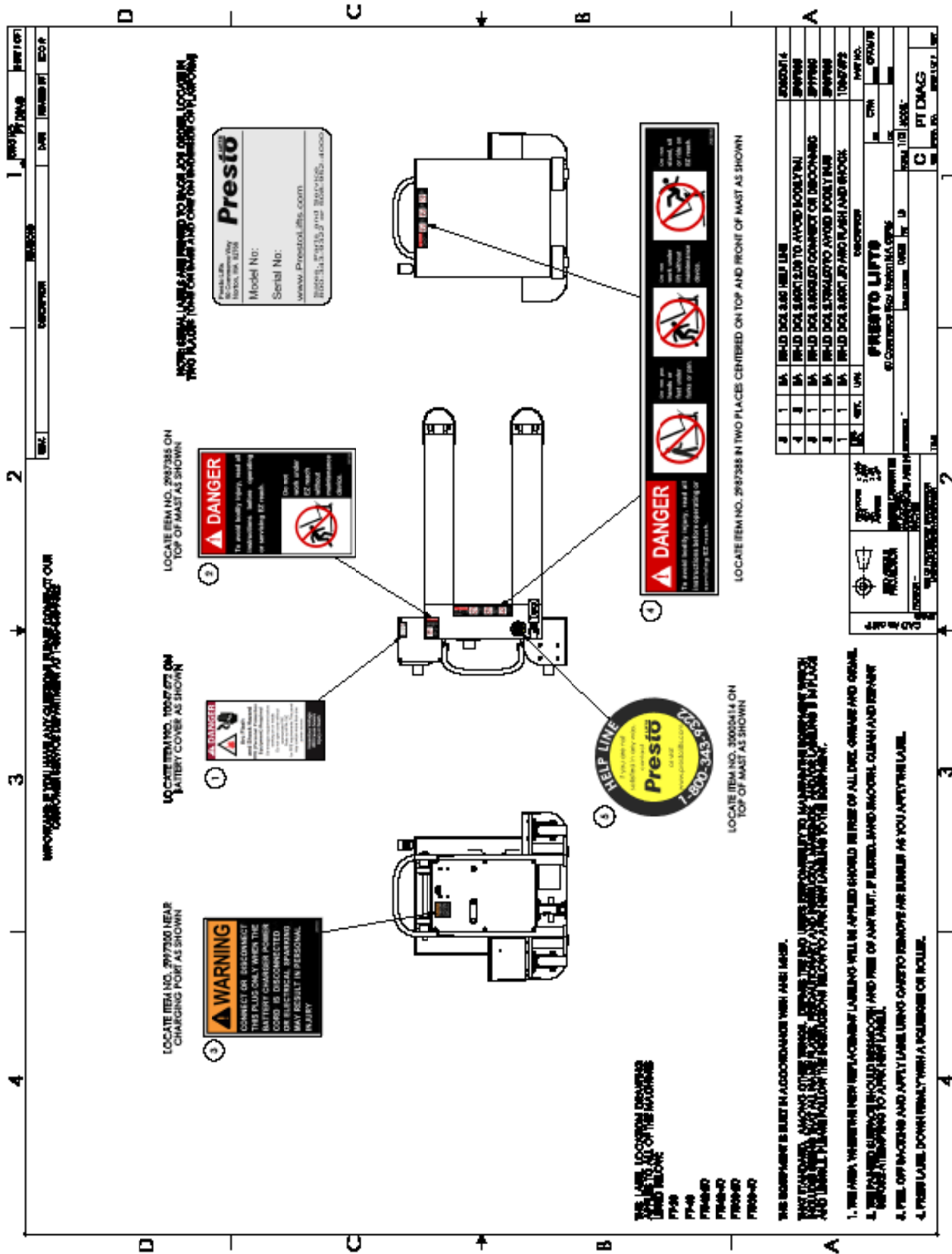

FIGURE 5: Component Identification - DC Units





PARTS

Standard parts may be returned with a 20% restocking fee. Modified or custom-engineered parts are not returnable. Unfortunately, due to potentially concealed damage, all sales of electrical assemblies are final.

QUALITY ISSUES

Should you feel there is a quality problem, please contact the seller to ask questions and gather information on how to rectify the issue. Presto Lift Inc. reserves the right to determine potential credits, as a result of factory defects, based on its inspection of the merchandise.

GENERAL

All products shipped from our factory have passed Quality Assurance inspection and testing. The carrier of choice has signed for, and accepted the product in new working condition. The customer should inspect to ensure it is not received damaged, has no concealed damage or is not incomplete. Parts orders are determined to be complete based upon Presto Lift, Inc. inspection sheets and carrier shipping weights.

RETURN GOODS AUTHORIZATION POLICY

Presto Lifts provides the Return Goods Authorization (RGA) Policy, for specific models, as a courtesy to our distributors in the event they do not receive what they ordered. If a customer wishes to return a Presto Lifts product, please contact the Customer Service Department and request an RGA number. This request must be made on or before the fifteenth calendar day following the date of Presto Lifts' invoice for the merchandise. Not all units are returnable. Quantity orders and special designs cannot be returned under any circumstances. Presto Customer Service reserves the right for final judgment on all product returns.

The RGA number must appear on the outside of any packaging material for a return to be accepted and processed by Presto Lifts. Customers shipping returns from the Continental US, Canada, or Mexico have thirty (30) days from date of RGA issue to have the product arrive at Presto Lifts' facility. All merchandise must arrive Free on Board at Presto Lifts' facility or the shipment will be refused and returned to the sender. All credits are issued less restocking and refurbishing charges, regardless if the merchandise was damaged in transit.

Return addresses: please refer to your RMA for the address to which your product should be returned.

Presto Lift Inc.
715 Highway 77
Manila, Arkansas 72442

Telephone: 800-343-9322
Fax: 888-788-6496

Ordering Replacement Parts

Presto Lifts has carefully chosen the components in your unit to be the best available for the purpose. Replacement parts should be identical to the original equipment. Presto Lifts will not be responsible for equipment failures resulting from the use of incorrect replacement parts or from unauthorized modifications to the unit.

Presto Lifts can supply all replacement parts for your lift. With your order, please include the model number and the serial number of the unit. You can find these numbers on the name plate. This plate is located within the scissors mechanism.

To order replacement parts, please call the Presto Parts Department. Parts are shipped subject to the following terms:

- FOB factory
- Returns only with the approval of our parts department.
- Credit cards preferred (except parts covered by warranty).
- Freight collect for truck (except parts covered by warranty).
- Freight – prepaid and invoice for small parcel shipments (except parts covered by warranty).
- The warranty for repair parts is 30 days from date of shipment.

Parts replaced under warranty are on a “charge-credit” basis. We will invoice you when we ship the replacement part, then credit you when you return the worn or damaged part, and we verify that it is covered by our warranty. Labor is not covered under warranty for Parts orders.

Presto Parts Department

50 Commerce Way
Norton, MA 02766

Telephone: 800-343-9322

FAX: 888-788-6496

Email: service@PrestoLifts.com

www.PrestoLifts.com

Presto Lifts Limited Warranty Policy

Presto Lifts warrants all of its products against defects in the welded structural frame and, if applicable, scissor legs from faulty material and workmanship for a period of five (5) years from the date of invoice.

All batteries and battery chargers have a limited warranty against defects in faulty material and workmanship for a ninety (90) day period from the date of invoice through Presto Lifts.

All other components have a limited warranty against defects in faulty material and workmanship for a two (2) year period from the date of invoice date of invoice and a 30 day limited warranty on labor. Please note that prior authorization from Presto Lifts is required on all warranty work.

There are no implied warranties of any kind, more specifically, there are no warranties of merchantability or fitness for any particular purpose. Presto Lifts' sole warranty shall be as set forth in this limited warranty.

Presto Lifts will elect to repair or replace a defective component without charge, if any components should become defective within the limited warranty period. Proof of purchase is required for warranty. The charge for shipping the defective component is the responsibility of the buyer and must be accompanied with an RMA number. The shipping charge to return the component to the buyer is the responsibility of Presto Lifts, Inc.

This limited warranty does not cover labor expense for removal or reinstallation of components after thirty days. This limited warranty shall not cover, among other things: damages resulting from foreign matter or water, failure to provide reasonable and necessary maintenance, and if applicable, use of product while charger is plugged into an AC outlet, or failure to follow operating instructions. The limited warranty is not valid for damage resulting from negligence, accident, unreasonable use, abuse or misuse, exceeding data plate capacities or altering the product without Presto Lifts authorization.

Presto Lifts expressly disclaims and excludes any liability for consequential, incidental, indirect or punitive damages or financial loss to people or property resulting from any breach of warranty or the operation or failure of this product.

Presto Lifts makes no representation that this product complies with local, state, or federal safety/product standards codes. Should this product fail to comply in any way with those codes, it shall not be considered a defect of materials or workmanship. Presto Lifts shall not be held liable for any damages resulting from noncompliance. It is the dealer's responsibility to exercise this limited warranty. This limited warranty is provided to the original purchaser (defined as the original end user) and is nontransferable. This constitutes the complete and final agreement involving Presto Lifts and limited warranty obligations for products.

MANY NEEDS REQUIRE MANY OPTIONS...

Presto LIFTS



LET PRESTO MEET THOSE NEEDS!

Call Presto Sales
for stock or
customized lift inquiries:
800-343-9322

Email: sales@prestolifts.com

