

WP & WPS Series Work Positioners

Installation, Operation and Service Manual

Model Number _____

Serial # _____

Date placed in service _____

**IMPORTANT: READ CAREFULLY
BEFORE INSTALLING OR OPERATING LIFT**

Part orders are subject to a \$50 minimum charge.



This manual was current at the time of printing. To obtain the latest, most updated version, please contact Presto Lifts Customer Service Department or go to our website: www.PrestoLifts.com -- you will find a complete list of current owner's manuals to print.

TABLE OF CONTENTS

SECTION 1:	
Introduction.....	4
Responsibility of Owners and Users.....	5
SECTION 2:	
Safety Alert Symbols and Signal Words.....	6
Safety.....	8
SECTION 3:	
Installation.....	8
A. Inspection.....	8
B. Removing from Pallet.....	8
SECTION 4:	
Operation.....	9
A. Operating Instructions.....	9
B. Daily Operations Maintenance Checks.....	9
SECTION 5:	
Maintenance.....	10
A. Instructions.....	10
B. Monthly Operations Maintenance Checks.....	10
SECTION 6:	
Service.....	10
ORDERING REPLACEMENT PARTS.....	20
RESTOCKING POLICY.....	21
RETURN MATERIALS AUTHORIZATION (RMA) PROCEDURES.....	21
LIMITED WARRANTY.....	23

List of Figures

Figure 1: Model WP.....	11
Figure 2: Model WPS.....	11
Figure 3: WP & WPS Rear View.....	11
Figure 4: Steering Assembly.....	12
Figure 5: Floor Lock Assembly.....	13
Figure 6: Chain Roller Assemblies.....	13
Figure 7: 1000, 1500 & 2700 lb. Cylinder.....	14
Figure 8: 2000 lb. Capacity Cylinder.....	14
Figure 9: Work Positioner Back Plate Assembly.....	15
Figure 10: DC Power Wiring Schematic.....	16
Figure 11: Old Style Standard DC Power Pack Illustration.....	16
Figure 12: Old Style DC Power Pack With Remote Control Illustration.....	16
Figure 13: AC Power Wiring Schematic.....	17
Figure 14: Old Style Standard AC Power Pack Illustration.....	17
Figure 15: Old Style AC Power Pack With Remote Control Illustration.....	17
Figure 16A: New Style DC Power Pack for stackers.....	18
Figure 16B: New Style DC Power Pack for stackers (end view).....	19

List of Tables

Table 1: Steering Components.....	12
Table 2: Cylinder Components.....	14

SECTION 1

INTRODUCTION

This manual attempts to provide all of the information necessary for the safe and proper installation, operation and maintenance of Presto's Battery Operated Work Positioner. It is important that all personnel involved with the installation, maintenance or operation of the Work Positioner read this manual. Additional manuals are available at www.prestolifts.com

The battery-operated Work Positioner is equipped with a data plate that has a serial number and model identification. Please refer to these numbers when ordering parts or requesting further information.

The battery-operated Work Positioner is designed for lifting, lowering and positioning a wide variety of loads. Call Presto for further instructions where unique situations arise that are not covered in this manual.

The battery-operated Work Positioner is designed for only indoor, non-hazardous locations. These units are not for personnel lifting. All equipment is manually propelled and has a hydraulically powered vertical travel.

Responsibility of Owners and Users

Inspection and Maintenance

The device shall be inspected and maintained in proper working order in accordance with Presto's owner's manual.

Removal from Service

Any device not in safe operating condition such as, but not limited to, excessive leakage, missing rollers, pins, or fasteners, any bent or cracked structural members, cut or frayed electric, hydraulic, or pneumatic lines, damaged or malfunctioning controls or safety devices, etc. shall be removed from service until it is repaired to the original manufacturer's standards.

Repairs

All repairs shall be made by qualified personnel in conformance with Presto's instructions.

Operators

Only trained personnel and authorized personnel shall be permitted to operate PowerStak.

Before Operation

Before using the device, the operator shall have:

- Read and/or had explained, and understood, the manufacturer's operating instructions and safety rules.
- Inspected the device for proper operation and condition. Any suspect item shall be carefully examined and a determination made by a qualified person as to whether it constitutes a hazard. All items not in conformance with Presto's specification shall be corrected before further use of the PowerStak.

During Operation

The device shall only be used in accordance with this owner's manual.

- Do not overload.
- Ensure that all safety devices are operational and in place.

Modifications or Alterations

Modifications or alterations to any Presto industrial positioning equipment shall be made only with written permission from Presto.

SAFETY ALERT SYMBOLS AND SIGNAL WORDS

The safety of all persons operating, maintaining, repairing, or in the vicinity of this equipment is of paramount concern. This is a powerful machine with moving parts, and is capable of causing personal injury if proper precautions are not taken. Therefore, throughout this manual, certain hazards have been identified which may occur in the use of the machine, and there are appropriate instructions or precautions which should be taken to avoid these hazards. In some cases, there are consequences which may occur if instructions or precautions are not followed. Below are the symbols and signal words along with their definitions referenced from ANSI Z535.4 - Product Safety Signs and Labels.

Safety Alert Symbols

These are the safety alert symbols.. They are used to alert you to potential physical injury hazards. Obey all safety messages that follow this symbol to avoid possible injury or death.



For use with DANGER signal word
(Red Background)



For use with WARNING signal word
(Orange Background)



For use with CAUTION signal word
(Yellow Background)

Signal Words

The meaning of different signal words as defined by ANSI Standard Z535.4 indicates the relative seriousness of the hazardous situation.



(Red Background)

DANGER indicates a hazardous situation which, if not avoided, will result in death or serious injury.



(Orange Background)

WARNING indicates a hazardous situation which, if not avoided, could result in death or serious injury.



(Yellow Background)

CAUTION, used with the safety alert symbol, indicates a hazardous situation which, if not avoided, could result in minor or moderate injury.



(Blue Background)

NOTICE is used to address practices not related to personal injury.



(Green Background)

SAFETY INSTRUCTIONS (or equivalent) signs indicate safety-related instructions or procedures.

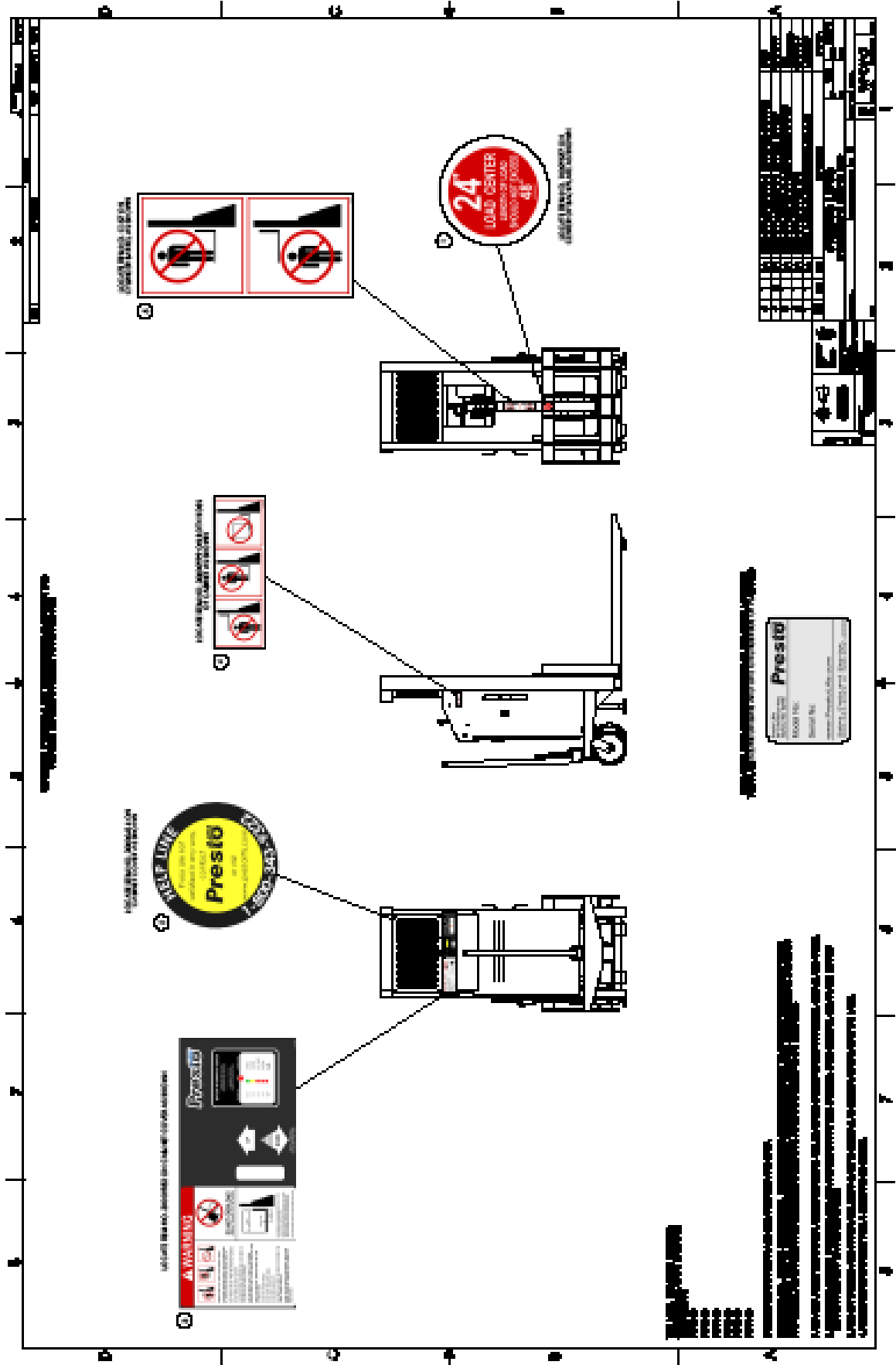

SECTION 2

SAFETY

The battery-operated Work Positioner is a very powerful lift capable of doing large amounts of work.

Carefully read this manual before installing or operating this lift. Some hazards have been identified that may occur during the installation, maintenance and use of this lift.

⚠WARNING

- Do not perform any repair work on lifts if there is a load on the forks or platform.
- Do not perform any repair work if the forks or platform is in the raised position.
- All personnel must stand clear of the lift while in motion.
- Do not put hands or feet under the forks or platform.
- Do not stand underneath the forks or platform.
- Do not stand in front of the Work Positioner while in motion.
- Do not stand, sit or climb on the lift.
- Do not use the lift on soft, uneven or unstable surfaces.
- Do not exceed the load center or capacity.

SECTION 3

INSTALLATION

A. INSPECTION

The lift is tested and inspected prior to shipment. Inspect the Work Positioner completely upon receipt, to determine if there is any damage caused during shipment by the freight company and that the lift is complete. A freight claim must be filed with the freight company if damage is apparent. Do Not use the lift if there appears to be any damage. Check the following with the lift in a collapsed position:

- Check for signs of damage especially to the back cabinet that houses the battery, electrical/hydraulic power pack.

- Check all connections for tightness. Is there hydraulic fluid visible?
- Check base frame for dimensions and structural integrity.
- Inspect for any bent or damaged metal parts.

B. REMOVING FROM PALLET:

Remove all packaging materials prior to removing the lift from the pallet. Visually inspect the lift as closely as possible.

Carefully pick up the lift taking into consideration the center of gravity of the lift with an overhead hoist or forklift. Use a hoist and nylon sling with a minimum of 2,000-lb capacity if you choose to pick the lift up with an overhead hoist. Pick the lift up by the top cross member of the lift. Have all personnel completely cleared from the area because the lift will begin to swing when it is clear of the pallet.

Pick the lift up approximately six inches above the pallet. Once raised and secure remove the pallet from below the lift then lower the lift.

SECTION 4

OPERATION

A. OPERATING INSTRUCTIONS:

1. To raise the lift, push the control handle or activate the UP BUTTON on a remote control.
2. To lower the lift, pull the control handle or activate the DOWN BUTTON on a remote control.
3. Whenever the controls are released, the lift stops.

AUTHORIZED OPERATORS SHOULD READ AND UNDERSTAND ALL INSTRUCTIONS, PRECAUTIONS AND WARNINGS. IMPROPER USE OF THIS LIFT COULD RESULT IN INJURY AND/OR DAMAGE TO THE LOAD AND/OR EQUIPMENT.

- Inspect the lift for damaged or worn parts. Do not use if not in safe operating condition.
- Use lift only on hard level surfaces.
- Make sure load is evenly distributed, not loose or unstable and is as far back as possible on the platform or forks. Do not pick up loads on the tips of the forks or edge of platform.
- Adjust forks to the maximum practical width on a fork model lift if they are adjustable. Pick loads up on both forks, not one.
- Do not overload. Check load center and lift weight capacities that are located on the data plate.
- Make sure work area is clear of all obstructions.
- Check overhead clearance before lifting loads or transporting.
- Make sure floor lock pad is in firm contact with floor before lifting load, lowering load or using as a workstation.
- Brace or block lift when sliding loads on or off platform or forks.

B. DAILY OPERATIONS MAINTENANCE CHECKS:

1. Battery

- Check for corroded and loose terminals. A white powder substance will be present if there is any existing corrosion.
- Check for loose battery tie-downs.
- Visually inspect for any cracks or damage to the casing.

2. Charger

- Inspect wire connections.
- Check power cord for nicks/damage.
- Check charger for proper mounting.

3. Hydraulic System

- Inspect pump and cylinder for oil leaks.
- Check hydraulic oil level. Unscrew breather plug on power unit with forks platform fluid will be $\frac{1}{2}$ - $\frac{3}{4}$ of an inch from opening all the way down.
- Check hydraulic fittings and hoses

4. Frame Assembly

- Check floor lock.
- Check placement of safety screen.
- Check chain roller assembly.
- Check for any worn or damaged parts.

SECTION 5

MAINTENANCE

A. INSTRUCTIONS:

- Grease wheels and casters at least once a month to maintain easy roll of lift.
- Use only Hydraulic Oil (Conoco Super Hydraulic 32 or equivalent) in the hydraulic system. NEVER USE HYDRAULIC BRAKE FLUID.
- *Do not* overload your lift.

B. MONTHLY MAINTENANCE CHECKS:

1. Battery

- Clean terminals.
- Clean battery compartment area.
- Check specific gravity -- fully charged battery should read 1265.
- Check fluid level in all cells. Fill with distilled water as necessary to bring fluid to within $\frac{3}{4}$ " of the top.

2. Hydraulic System

- Clean and inspect hydraulic cylinder.
- Lubricate chains with a rust inhibitive chain lubricant.
- Check chain tension. The chains should be tight enough so that they do not come off the chain roller assembly. The tension should be adjusted so that the chains bear equal amounts of load weight.

3. Frame Assembly

- Clean and lubricate all roller bearings and cam followers.
- Clean and inspect all welds.
- Check wheels for wear and damage.
- Inspect nameplate for legibility. Place the serial and model number shown on the nameplate on the cover of the manual for future reference.

SECTION 6

SERVICE

IF LIFT DOES NOT RISE TO FULL HEIGHT -- check for leaks or shortage of oil. Maintain the proper oil level.

IF THE LIFT TENDS TO CREEP DOWNWARD UNDER A LOAD -- a speck of dirt may be obstructing the seating of the valve and allowing leakage. To correct, follow these instructions:

- Raise lift to full lifting height and then lower it to lowest point of lift. It may be necessary to do this five or six times. In lowering the lift, lower it in stages, that is, lower the lift six inches to a foot at a time. This will dislodge the dirt and lift will operate properly.

WP Component Identification	
Item	Description
1	Cylinder
2	Flow Control Valve
3	Chain Roller Assembly
4	Load Wheel
5	Floor lock Assembly
6	Lead Wheel

Figure 1: Model WP

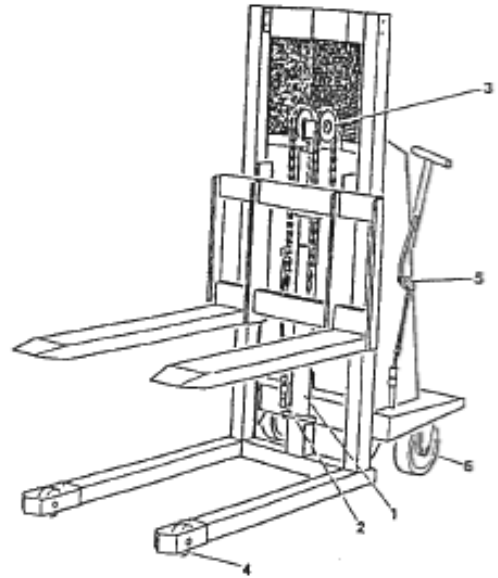
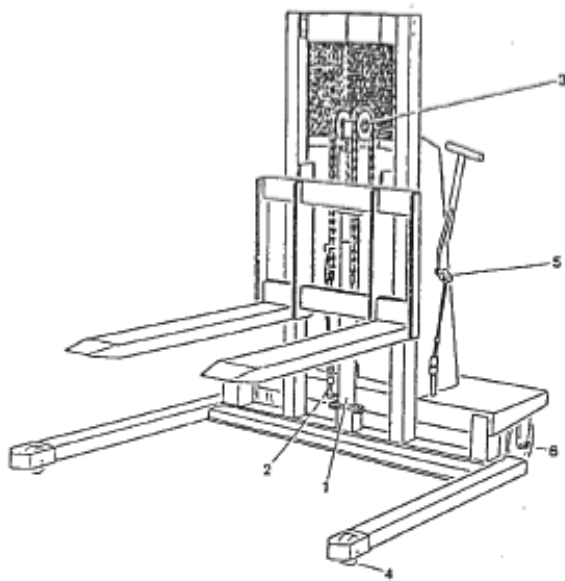

Figure 2: Model WPS



WPS Component Identification	
Item	Description
1	Cylinder
2	Flow Control Valve
3	Chain Roller Assembly
4	Load Wheel
5	Floor lock Assembly
6	Lead Wheel

Component Identification of Rear View of WP and WPS	
Item	Description
4	Load Wheel
5	Floor lock Assembly
6	Lead Wheel
7	Slave Wheel
8	Battery
9	DC Motor
10	Battery Charger
11	Steering Handle
12	Operating Lever

Figure 3: WP & WPS Rear View

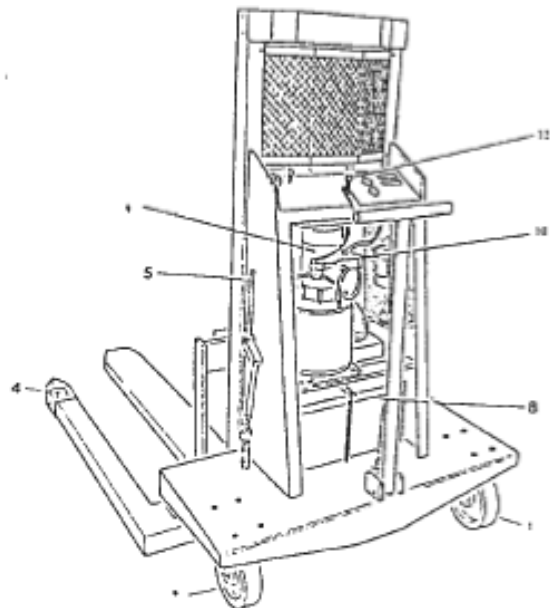

Table 1: Steering Components		Steering Assembly Item and Part Numbers
Item Number	Description and Part Number	
1	N0338 - Washer	
2	N0817 - Bolt	
3	N0250 - Washer, Lock	
4	1004-026 - Bearing	
5	72045-6 - Shaft, Collar	
6	Bearing Holder	
7	1004-010 - Bar, Actuator	
8	1004-043 - Pivot Assembly	
9	1004-025 - Collar With Set Screw	
10	1004-042-01 - Pivot Link (WP)	
10	1004-042-02 - Pivot Link (WPS)	
11	1004-030 - Assembly, Actuator	
12	1004-024-01 - Spring	
13	Assembly Handle	
14	Caster Assembly with Actuator	
15	N1255 - Pin (Expansion)	
16	N1275 - Pin (Expansion)	
17	N1280 - Pin Clevis	
18	Wheel With Bearing 8x2, 1000# & 2000# Capacity	
18	Wheel With Bearing 8x2, 3000# & 4000# Capacity	
19	Coupling	
20	N1081 - Screw	
20	N0280 - Washer	
20	N0160 - Nut	
20	Spacer	

Figure 4: Steering Assembly

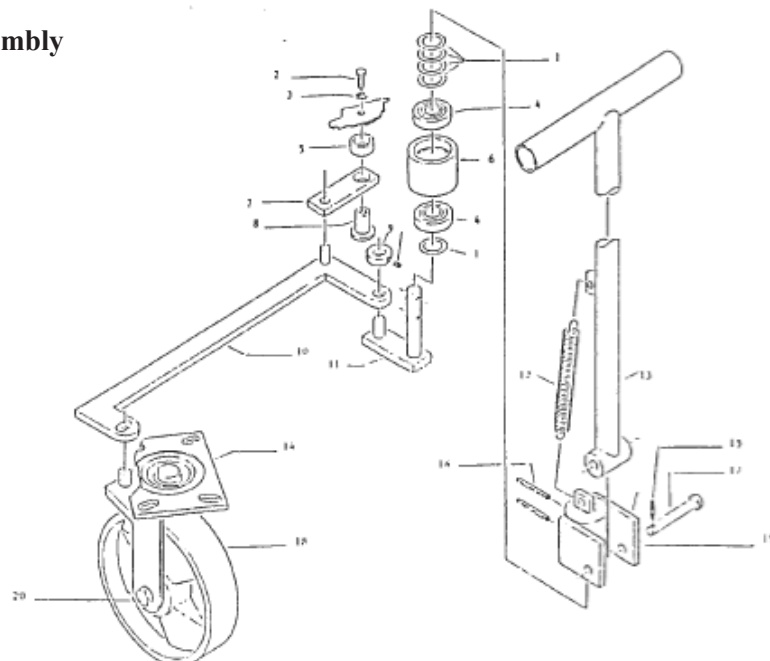

Figure 5: Floor Lock Assembly

Floor Lock Assembly Detail	
Item	Description
1	Handle, Lock
2	N0180 – Nut, Lock Handle
3	Spacer
4	N1110 – Bolt, Lock Handle
5	PSL28A – Rings, Retaining
6	PSL28 – Pin
7	Lever, Lock
8	2340772 – Nut, Locking
9	10029220 – Stud, Adjusting
10	PSL24 – Mount, Rubber
11	PSL26 – Spring, Lock Return
12	PSL21D – Holder, Foot Pad
13	M437 – Pad, Foot

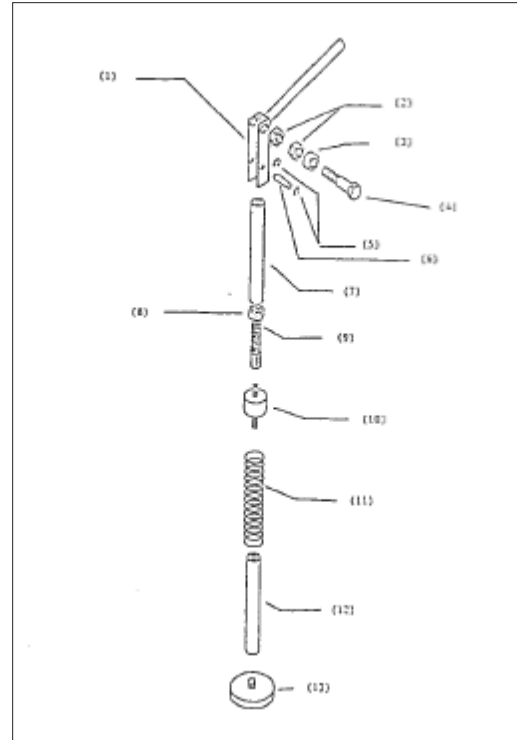

Figure 6: Chain Roller Assemblies; Assemblies Only, No Parts Available.

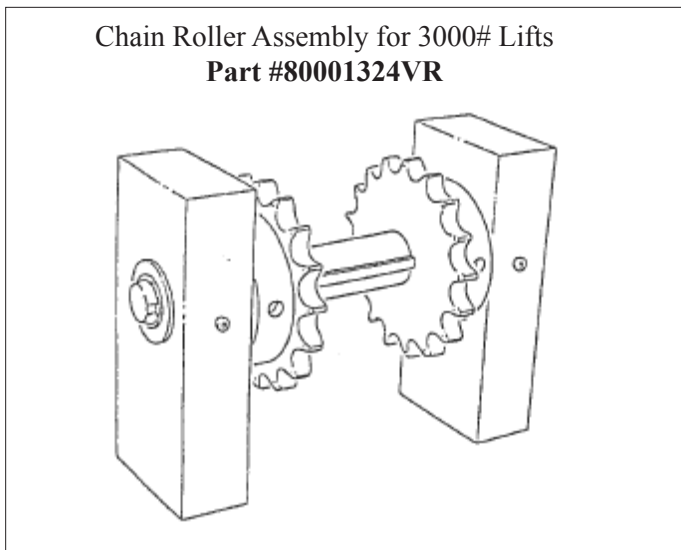

Figure 7: 1000, 1500 & 2700 lb. Cylinder

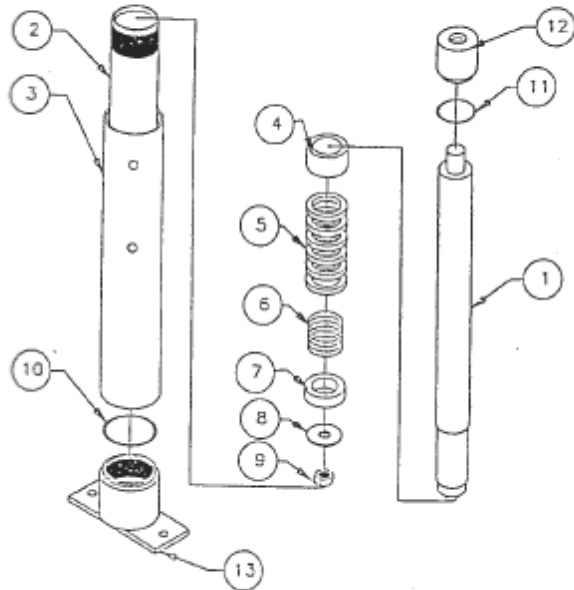

Figure 8: 2000 lb. Capacity Cylinder

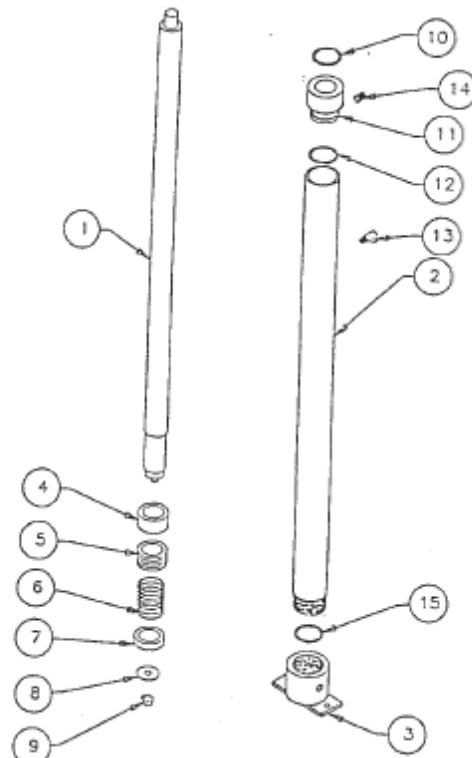
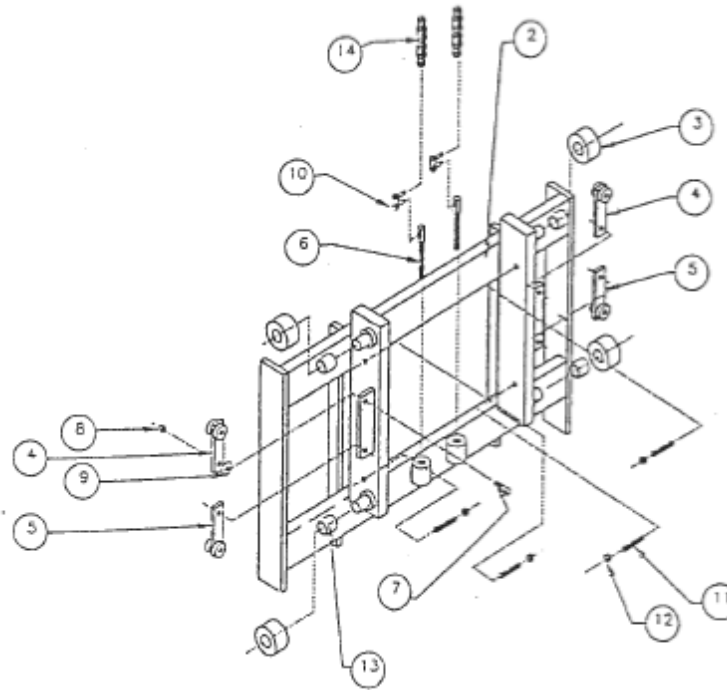

Table 2: Cylinder Components

Figure 3: Cylinder Parts for 1000 & 3000 Lifts	
Item	Description
1	Cylinder Ram
2	Inner Cylinder
3	Outer Cylinder
4	Bearing Chevron Support
5	Chevron Set
6	Chevron Spring
7	Ram Guide
8	Washer Ram Guide
9	Nut Ram Guide
10	“O” Ring Cyl. Base
11	“O” Ring Ram Seal
12	Cap Cylinder
13	Base Cylinder
14	Seal Kit: Items 4-12

Figure 4: Cylinder Parts for 2,000 lb. Lifts	
Item	Description
1	Cylinder Ram
2	Inner Cylinder
3	Base Cylinder
4	Bearing Chevron Support
5	Chevron Set
6	Chevron Spring
7	Ram Guide
8	Washer Ram Guide
9	Nut Ram Guide
10	“O” Ring Upper Cap
11	Cylinder Cap
12	“O” Ring Lower Cap
13	Fitting
14	Set Screw, Vent Plug
15	“O” Ring Ram Seal
16	Seal kit: Items 4-12 plus 15

Figure 9: Work Positioner Back Plate Assembly



Work Positioner Back plate Assembly

Note Item#1-A & -B include 2 thru 13

Item#	P/N#	Description	Qty.
1-A		Back plate and fork assembly 42" forks (forks not shown)	1
-B		Back plate and fork assembly 48" forks (forks not shown)	1
2-A		Back plate and fork assembly 42" forks (forks not shown)	1
2-B		Back plate and fork assembly 48" forks (forks not shown)	1
3		Guide Roller Assembly	4
4		Guide Thrust Left	2
5		Guide Thrust Right	2
6		Adjusting Stud	2
7	NO940	3/8-16x1 1/4 hex head bolt	4
8	NO100	3/8-16 hex nut	4
9	NO324	3/8 ID X 1" CD flat washer	4
10	L434	Link, connector	2
11	NO550	3/8-16 x 2" socket set screw	4
12	NO120	Nut, jam 3/8-16	4
13	C184	Race, bearing (loctite to stud)	4
14	C104-XX	Lift Chain	2

XX = Lift Chain

Figure 10:DC Power Wiring Schematic

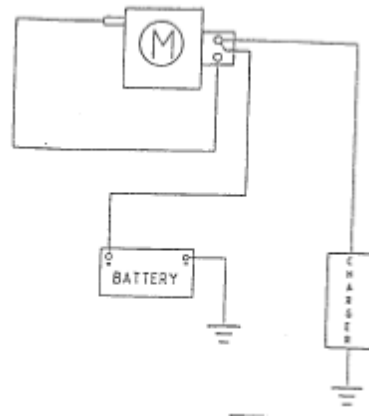

Figure 11: Old DC Power Pack

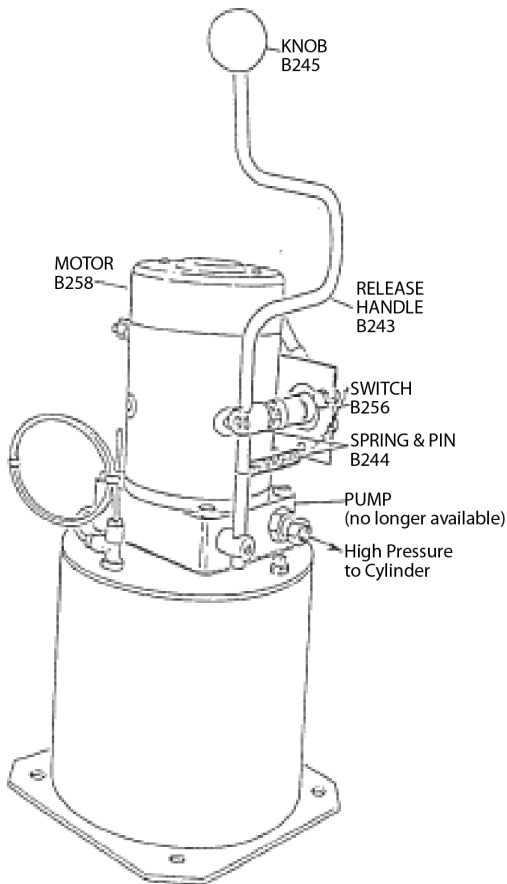

Figure 12: Old DC Power Pack w/ Remote Control

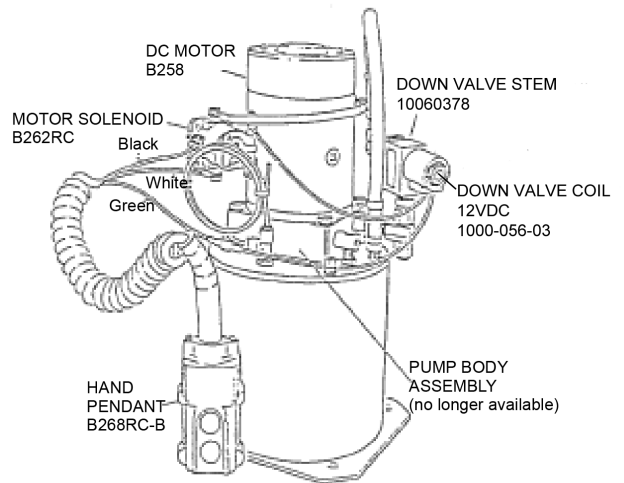

Figure 13: AC Power Wiring Schematic

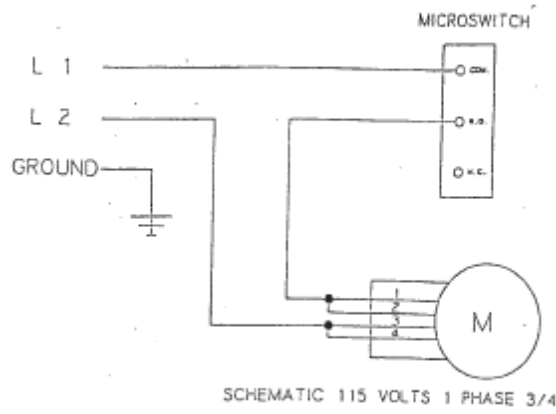

Figure 14: Old Style Standard AC Power Pack

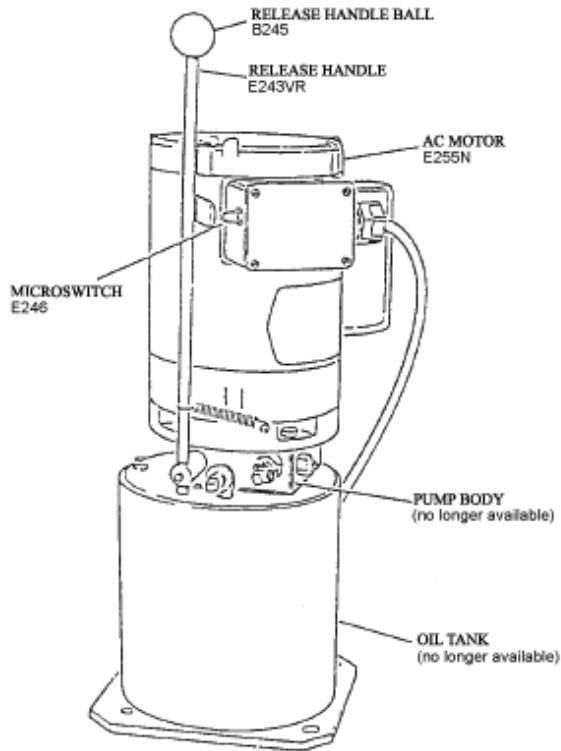

Figure 15: Old Style AC Power w/ Remote Control

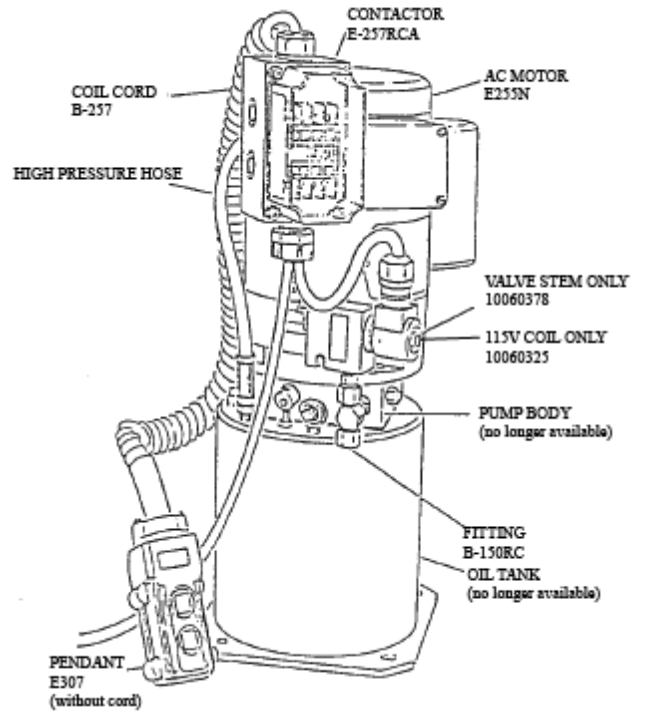
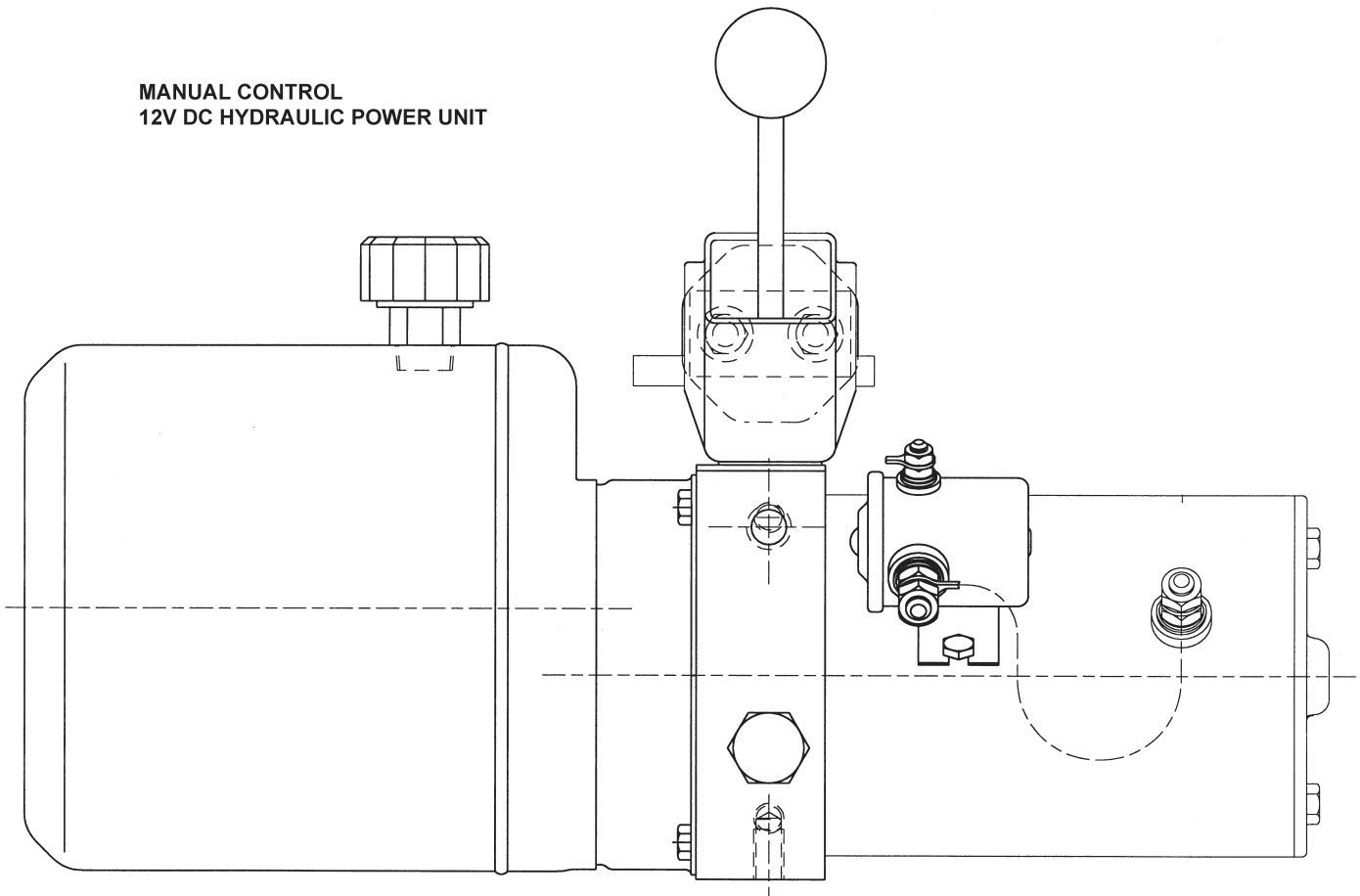
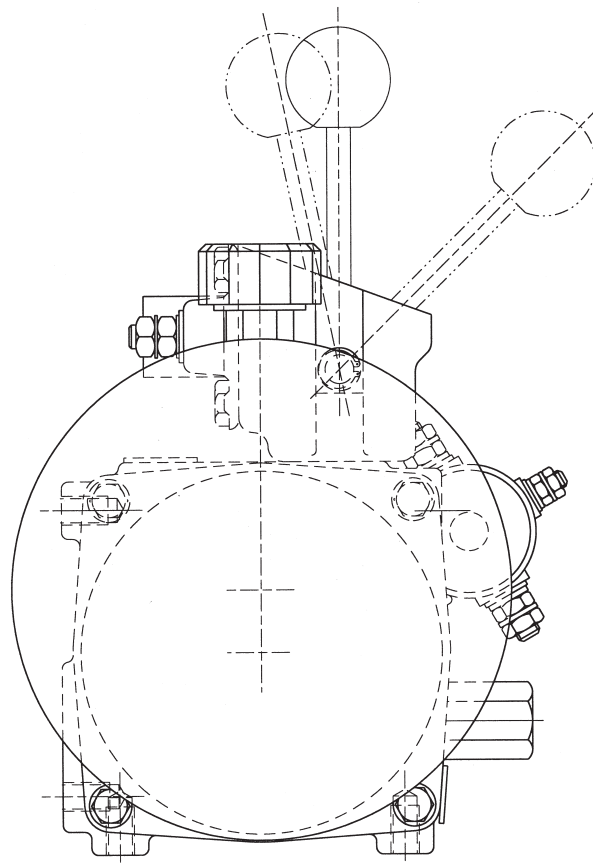

Figure 16A: New Style DC Power Pack for stackers



Call the Presto Parts department to determine available parts for the new style power unit. Have the model and serial number of the lift available.

Figure 16B: New Style DC Power Pack for stackers (end view)



Ordering Replacement Parts

Presto Lifts has carefully chosen the components in your unit to be the best available for the purpose. Replacement parts should be identical to the original equipment. Presto Lifts will not be responsible for equipment failures resulting from the use of incorrect replacement parts or from unauthorized modifications to the unit.

Presto Lifts can supply all replacement parts for your lift. With your order, please include the model number and the serial number of the unit. You can find these numbers on the name plate. This plate is located within the cabinet, or the angle iron cylinder cross support.

To order replacement parts, please call the Presto Parts Department. Parts are shipped subject to the following terms:

- FOB factory
- Returns only with the approval of our Parts Department.
- Credit cards preferred (except parts covered by warranty).
- Freight collect for truck (except parts covered by warranty).
- Freight - prepaid and invoice for small parcel shipments (except parts covered by warranty).
- The warranty for repair parts is 30 days from date of shipment.

Parts replaced under warranty are on a “charge-credit” basis. We will invoice you when we ship the replacement part, then credit you when you return the worn or damaged part, and we verify that it is covered by our warranty. Labor is not covered under warranty for Parts orders.

Presto Lifts Parts Department

50 Commerce Way, Norton, MA 02766

Telephone: 800-343-9322

FAX: 888-788-6496

Email: Service@PrestoLifts.com

www.PrestoLifts.com

PARTS

Standard parts may be returned with a 20% restocking fee. Modified or custom-engineered parts are not returnable. Unfortunately, due to potentially concealed damage, all sales of electrical assemblies are final.

QUALITY ISSUES

Should you feel there is a quality problem, please contact the seller to ask questions and gather information on how to rectify the issue. Presto Lift Inc. reserves the right to determine potential credits, as a result of factory defects, based on its inspection of the merchandise.

GENERAL

All products shipped from our factory have passed Quality Assurance inspection and testing. The carrier of choice has signed for, and accepted the product in new working condition. The customer should inspect to ensure it is not received damaged, has no concealed damage or is not incomplete. Parts orders are determined to be complete based upon Presto Lift, Inc. inspection sheets and carrier shipping weights.

RETURN GOODS AUTHORIZATION POLICY

Presto Lifts provides the Return Goods Authorization (RGA) Policy, for specific models, as a courtesy to our distributors in the event they do not receive what they ordered. If a customer wishes to return a Presto Lifts product, please contact the Customer Service Department and request an RGA number. This request must be made on or before the fifteenth calendar day following the date of Presto Lifts' invoice for the merchandise. Not all units are returnable. Quantity orders and special designs cannot be returned under any circumstances. Presto Customer Service reserves the right for final judgment on all product returns.

The RGA number must appear on the outside of any packaging material for a return to be accepted and processed by Presto Lifts. Customers shipping returns from the Continental US, Canada, or Mexico have thirty (30) days from date of RGA issue to have the product arrive at Presto Lifts' facility. All merchandise must arrive Free on Board at Presto Lifts' facility or the shipment will be refused and returned to the sender. All credits are issued less restocking and refurbishing charges, regardless if the merchandise was damaged in transit.

Return addresses: please refer to your RMA for the address to which your product should be returned.

Presto Lift Inc.
715 Highway 77
Manila, Arkansas 72442

Telephone: 800-343-9322
Fax: 888-788-6496

Presto Lifts Limited Warranty Policy

Presto Lifts warrants all of its products against defects in the welded structural frame and, if applicable, scissor legs from faulty material and workmanship for a period of five (5) years from the date of invoice.

All batteries and battery chargers have a limited warranty against defects in faulty material and workmanship for a ninety (90) day period from the date of invoice through Presto Lifts. All other components have a limited warranty against defects in faulty material and workmanship for a two (2) year period from the date of invoice and a 30 day limited warranty on labor. Please note that prior authorization from Presto Lifts is required on all warranty work.

There are no implied warranties of any kind, more specifically, there are no warranties of merchantability or fitness for any particular purpose. Presto Lifts' sole warranty shall be as set forth in this limited warranty.

Presto Lifts will elect to repair or replace a defective component without charge, if any components should become defective within the limited warranty period. Proof of purchase is required for warranty. The charge for shipping the defective component is the responsibility of the buyer and must be accompanied with an RMA number. The shipping charge to return the component to the buyer is the responsibility of Presto Lifts, Inc.

This limited warranty does not cover labor expense for removal or reinstallation of components after thirty days. This limited warranty shall not cover, among other things: damages resulting from foreign matter or water, failure to provide reasonable and necessary maintenance, and if applicable, use of product while charger is plugged into an AC outlet, or failure to follow operating instructions. The limited warranty is not valid for damage resulting from negligence, accident, unreasonable use, abuse or misuse, exceeding data plate capacities or altering the product without Presto Lifts authorization.

Presto Lifts expressly disclaims and excludes any liability for consequential, incidental, indirect or punitive damages or financial loss to people or property resulting from any breach of warranty or the operation or failure of this product.

Presto Lifts makes no representation that this product complies with local, state, or federal safety/product standards codes. Should this product fail to comply in any way with those codes, it shall not be considered a defect of materials or workmanship. Presto Lifts shall not be held liable for any damages resulting from noncompliance. It is the dealer's responsibility to exercise this limited warranty. This limited warranty is provided to the original purchaser (defined as the original end user) and is nontransferable. This constitutes the complete and final agreement involving Presto Lifts and limited warranty obligations for products.