

## P3 All-Around Spring Level Loader P3-SPRING



### Installation, Operation and Service Manual

Model Number \_\_\_\_\_

Serial # \_\_\_\_\_

Date Placed in Service \_\_\_\_\_

IMPORTANT: READ CAREFULLY

BEFORE INSTALLING OR OPERATING LIFT

Part orders are subject to a \$50 minimum charge.



---

This manual was current at the time of printing. To obtain the latest, most updated version, please contact the Customer Service Department or go to our website: [www.PrestoLifts.com](http://www.PrestoLifts.com) and you will find a complete list of current Owner's Manuals to print.

# Contents

INTRODUCTION .....	Page 4
RESPONSIBILITY OF OWNERS AND USERS .....	5
SAFETY .....	6
Safety Alert Symbols and Signal Words .....	7
Installation Notes .....	8
Operation Notes – Manual Use .....	8
Operation Notes – Use with Fork Lift or Stacker .....	9
SPECIFICATIONS .....	9
INSTALLATION INSTRUCTIONS .....	10
Unpacking the Unit .....	10
Spring Selection Charts .....	10
Installing the Optional Adjustable Feet .....	11
Installing the Springs .....	11-16
OPERATING INSTRUCTIONS .....	17
Loading Manually .....	17
Removing Loads Manually .....	17
Operating Safety – Manual use .....	17
Loading with a Fork Lift .....	17
Unloading with a Fork Lift .....	18
Moving the P3 All-Around Spring.....	18
MAINTENANCE .....	18
Routine Periodic Maintenance.....	18
TROUBLESHOOTING .....	19
ORDERING REPLACEMENT PARTS .....	20
WARRANTY .....	21

## List of Figures

Fig. 1	Safety Labels .....	8
Fig. 2	Pinch Points .....	8
Fig. 3	Orange Spring Installed .....	8
Fig. 4-17	Step by Step Installation .....	12 - 16
Fig. 18	Spring Mounting Positions .....	16
Fig. 19	Loading Manually .....	17
Fig. 20	Unloading Manually .....	17
Fig. 21	Loading with a Fork Lift .....	18
Fig. 22	Unloading with a Fork Lift .....	18
Fig. 23	Moving the P3 All-Around Spring .....	18

# Introduction

The P3 All-Around Spring Level Loader is a simple device which will automatically maintain a load at the ideal height for manual loading and unloading. If a palletized load is placed on the unit, the unit gradually rises as boxes or parts are removed. This automatically maintains the top of the load at the correct working height.

The unit may also be used in another way. An empty pallet may be placed on the P3 All-Around Spring. The unit gradually lowers as boxes or parts are added. Again, this keeps the top of the load at the correct height. Complete pallets may be loaded or unloaded using a fork lift.

Each P3 All-Around Spring unit includes a steel scissor lift mechanism and at least one large compression spring. The calibrated springs are chosen to match the weight and height of a fully loaded pallet. Springs are available for a wide range of weight and height combinations. The P3 All-Around Spring also includes a shock absorber. This eliminates any tendency for the load to bounce on the springs.

This manual contains information to help you to learn about the safe and proper installation, use, and upkeep of your P3 All-Around Spring unit. Please be sure that this manual is available to anyone who uses or services the P3 All-Around Spring unit.

P3 All-Around Spring units may be used in a wide variety of industrial settings. The instructions in this manual are not necessarily all-inclusive, as Presto cannot anticipate all conceivable or unique situations. **In the interest of safety, please read this whole manual carefully. Be familiar with the contents of this manual before you install or use the P3 All-Around Spring unit. If you are not sure of the proper procedure to be followed, please call Presto Lifts for more information.**

Presto's product warranty is shown on the rear cover of this manual. **This instruction manual is not intended to be or to create any other warranty, express or implied, including any implied warranty of merchantability or fitness for a particular purpose, all of which are hereby expressly excluded.** As set forth more specifically in the product warranty, Presto's obligation under that warranty is **limited** to the repair or replacement of defective components, which shall be the buyer's **sole remedy**, and Presto shall not be liable for any loss, injury, or damage to persons or property, nor for any direct, indirect, or consequential damage of any kind resulting from the P3 All-Around Spring unit.

# Responsibility of Owners and Users

## **Inspection and Maintenance**

The device shall be inspected and maintained in proper working order in accordance with Presto's owner's manual.

## **Removal from Service**

Any device not in safe operating condition such as, but not limited to, missing rollers, pins, or fasteners, any bent or cracked structural members, damaged or malfunctioning, etc. shall be removed from service until it is repaired to the original manufacturer's standards.

## **Deflection**

It is the responsibility of the user/purchaser to advise the manufacturer where deflection may be critical to the application.

## **Repairs**

All repairs shall be made by qualified personnel in conformance with Presto's instructions.

## **Operators**

Only trained personnel and authorized personnel shall be permitted to operate the positioner.

## **Before Operation**

Before using the device, the operator shall have:

- Read and/or had explained, and understood, the manufacturer's operating instructions and safety rules.
- Inspected the device for proper operation and condition. Any suspect item shall be carefully examined and a determination made by a qualified person as to whether it constitutes a hazard. All items not in conformance with Presto's specification shall be corrected before further use of the equipment.

## **During Operation**

The device shall only be used in accordance with this owner's manual.

- Do not overload.
- Ensure that all safety devices are operational and in place.

## **Modifications or Alterations**

Modifications or alterations to any Presto industrial positioning equipment shall be made only with written permission from Presto.

# Safety

The P3 All-Around Spring unit has been carefully designed to be as safe as possible for operators and service workers. If you take a few common-sense precautions, you will be able to use the unit safely. However, the P3 All-Around Spring is a powerful unit with moving parts, and is capable of causing personal injury if proper precautions are not taken.

Therefore, throughout this manual, Presto has identified certain hazards which may occur in the use and servicing of the P3 All-Around Spring unit, and provided appropriate instructions or precautions which should be taken to avoid these hazards. In some cases, Presto has also pointed out the consequences which may occur if Presto's instructions or precautions are not followed. Presto uses the following system of identifying the severity of the hazards associated with its products:

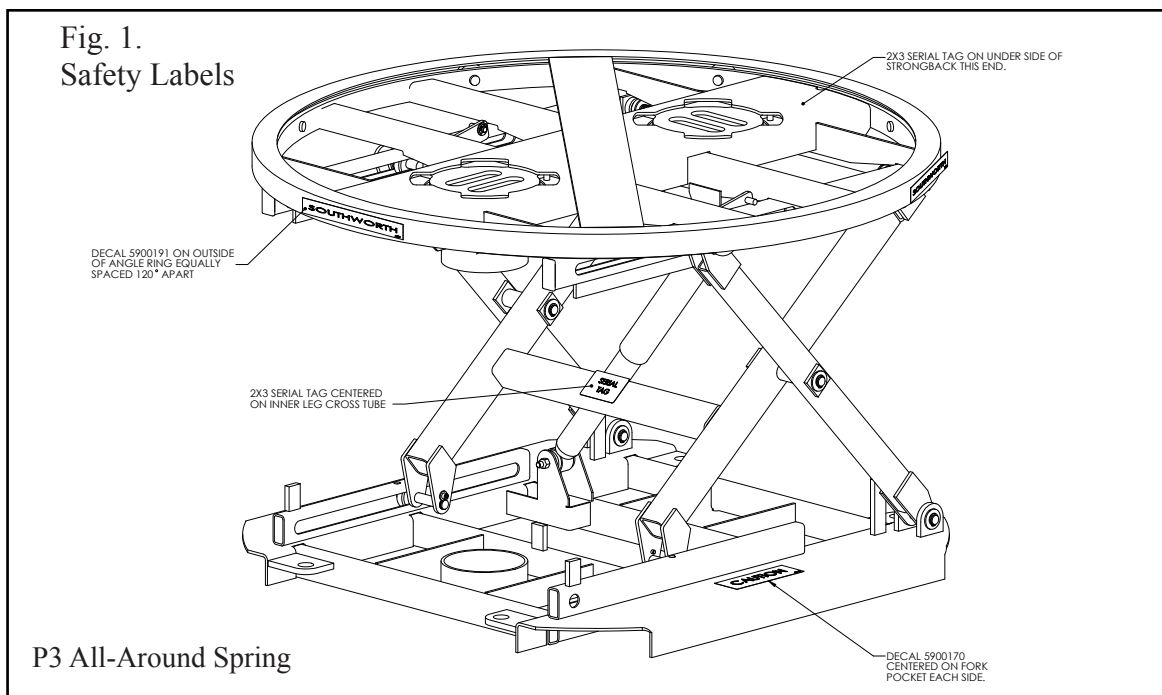
**⚠ DANGER** Immediate hazard which will result in severe personal injury or death.

**⚠ WARNING** Hazard or unsafe practice which could result in severe personal injury or death.

**⚠ CAUTION** Hazard or unsafe practice which could result in minor personal injury or property damage.

**Please read and follow this instruction manual, including all safety instructions and precautions, carefully and completely.**

Figure 1 shows the safety labels on this unit. Please be sure that all of the labels are in place, and are visible to the machine operators. Never paint over the labels. If any of the labels are missing, please contact Presto for replacements. **The safety labels help to protect your workers.**



# SAFETY ALERT SYMBOLS AND SIGNAL WORDS

The safety of all persons operating, maintaining, repairing, or in the vicinity of this equipment is of paramount concern. This is a powerful machine with moving parts, and is capable of causing personal injury if proper precautions are not taken. Therefore, throughout this manual, certain hazards have been identified which may occur in the use of the machine, and there are appropriate instructions or precautions which should be taken to avoid these hazards. In some cases, there are consequences which may occur if instructions or precautions are not followed. Below are the symbols and signal words along with their definitions referenced from ANSI Z535.4 - Product Safety Signs and Labels.

**4.11 Safety Alert Symbols:** A symbol that indicates a hazard. It is composed of an equilateral triangle surrounding an exclamation mark. The safety alert symbol is only used on hazard alerting signs. It is not used on safety notice and safety instructions signs.



**A): for use with DANGER signal word;** (safety white triangle, safety red exclamation mark, safety red background)

**B): for use with WARNING signal word;** (safety black triangle, safety orange exclamation mark)

**C): for use with CAUTION signal word;** (safety black triangle, safety yellow exclamation mark)

**D) and E): for use with DANGER, WARNING, or CAUTION signal word;** (D: is a safety yellow triangle with a black border and safety black exclamation mark; E: is a safety yellow triangle with a safety black exclamation mark and a safety yellow border around a safety black band)

NOTE: D and E are provided to allow for consistency with certain ISO standards such as ISO 3864-1 and ISO 3864-2.

**4.14 Signal Words:** The words used in the signal word panel. The signal words for hazard alerting signs are “DANGER,” “WARNING,” and “CAUTION.” Safety notice signs use the signal word “NOTICE.” Safety instruction signs use signal words that are specific to the situation.



DANGER indicates a hazardous situation which, if not avoided, will result in death or serious injury.



WARNING indicates a hazardous situation which, if not avoided, could result in death or serious injury.



CAUTION indicates a hazardous situation which, if not avoided, could result in minor or moderate injury.



NOTICE is used to address practices not related to physical injury.



SAFETY INSTRUCTIONS (or equivalent) signs indicate specific safety-related instructions or procedures.

NOTE: DANGER, WARNING or CAUTION should not be considered for property damage accidents unless personal injury risk appropriate to these levels is involved.



## Installation Notes

### NOTICE

The unit must be installed on a firm, nearly level surface. The frame of the unit must sit firmly on the floor, and the floor must be level. If the frame is not supported correctly, stresses may develop in the frame. The unit may bind or not work easily. The rotating ring may not rotate correctly.

### WARNING

After the springs are installed, if the springs are not seated correctly, or the twist-lock caps are not tightened, the parts may pop loose when the unit is used. You may be hurt, or the load may be damaged.

## Operation Notes – Manual Use

### WARNING

Never operate the unit if anyone is sitting or riding on the rotating ring.

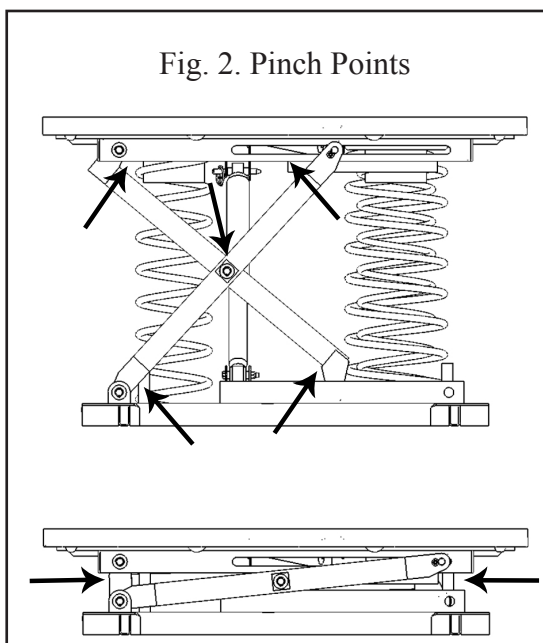
Never operate the unit if the load is off-center. The load may shift, and you may be injured. This can also damage the unit.

As the unit moves, keep away from the “pinch points” where metal parts meet. See Fig. 2.

Keep the area around the unit clean. Do not allow any dirt, debris, spilled oil, or excess grease to collect. These materials may cause you to slip while the unit is operating, and you may be injured.

Stay clear of the rotating ring when it is moving. As the pallet turns, a part of the load may rotate around and hit you. Never turn the load when anyone is standing beside the unit.

Do not try to use this unit with damaged or broken pallets. Broken pallets may have boards or nails which hang down below the main part of the pallet. As the pallet is turned, these boards or nails may catch on the frame of the unit. This can cause the pallet to stop turning suddenly, causing the load to shift.



You may be injured, and the unit may be damaged. The boards or nails on the bottom of the pallet should not extend down more than  $\frac{1}{8}$  inch.



## Operation Notes:

### Use with Fork Lift or Stacker

You must take some special precautions when using a fork lift or stacker with the unit:

#### When loading using a fork lift or stacker –

##### **⚠ WARNING**

When adding a load to the unit, lower the forks completely before removing the fork lift. The pallet must be completely supported by the P3 All-Around Spring. If you do not do this, the load may be dropped when you remove the fork lift. The unit or the load may be damaged, or you may be hurt. Figure 7 shows the correct way to load using a fork lift.

#### When unloading using a fork lift or stacker –

##### **⚠ WARNING**

When removing a load from the unit, lift the load clear of the P3 All-Around Spring before backing out the fork lift. If you do not do this, the top of the unit may jump up when you remove the fork lift. The unit or the load may be damaged, or you may be hurt. Figure 8 shows the correct way to unload using a fork lift.

#### When moving the P3 All-Around Spring -

##### **NOTICE**

Do not move the P3 All-Around Spring while it is loaded. This will damage the base frame of the unit. The pockets on the base frame are designed to support an unloaded P3 All-Around Spring, they cannot support any extra weight.

---

---

## Specifications

Load capacity .....	400 to 4500 lbs., depending on springs
Load size .....	50" wide x 50" long x 72" high (max.)
Length .....	45 <sup>1</sup> / <sub>4</sub> inches
Width (base frame) .....	36 <sup>3</sup> / <sub>4</sub> inches
Compressed height .....	9 <sup>1</sup> / <sub>2</sub> inches
Extended height .....	27 <sup>3</sup> / <sub>4</sub> inches
Rotating ring, outside diameter .....	43 <sup>5</sup> / <sub>8</sub> inches
Rotating ring, inside diameter.....	40 <sup>5</sup> / <sub>8</sub> inches
Adjustment for sloping floors .....	Can adjust for floor slope up to 1:25 using optional adjustable feet
Net weight .....	380 lbs., with (3) springs installed

# P3 All-Around Spring Selection Guide

		Weight of Fully Loaded Pallet (lbs and kgs)											
		0-400lb	400-800lb	800-1200lb	1200-1600lb	1600-2000lb	2000-2400lb	2400-2800lb	2800-3200lb	3200-3600lb	3600-4000lb	4000-4500lb	
		0-180kg	180-360kg	360-540kg	540-720kg	720-900kg	900-1080kg	1080-1260kg	1260-1440kg	1440-1620kg	1620-1800kg	1800-2025kg	
Height of Fully Loaded Pallet (ins. and mm)	58-60"	1475-1525 mm	0	0	1	1	1	1	2	2	2	3	3
	56-58"	1420-1475 mm	0	0	1	1	1	2	2	2	2	3	3
	54-56"	1370-1420 mm	0	0	1	1	1	2	2	2	2	3	3
	52-54"	1320-1370 mm	0	1	1	1	1	2	2	2	3	3	3
	50-52"	1270-1320 mm	0	1	1	1	1	2	2	2	3	3	4
	48-50"	1220-1270 mm	0	1	1	1	1	2	2	2	3	3	4
	46-48"	1170-1220 mm	0	1	1	1	1	2	2	3	3	3	4
	44-46"	1120-1170 mm	0	1	1	1	2	2	3	3	3	4	4
	42-44"	1065-1120 mm	0	1	1	2	2	2	3	3	4	4	4
	40-42"	1015-1065 mm	0	1	1	2	2	3	3	3	4	4	4
	38-40"	965-1015 mm	0	1	1	2	2	3	3	4	4	4	4
	36-38"	915-965 mm	0	1	1	2	2	3	4	4	4	4	4
	34-36"	865-915 mm	1	1	2	2	3	3	4	4	4	4	-
	32-34"	815-865 mm	1	1	2	3	3	4	4	4	4	-	-
30-32"	760-815 mm	1	1	2	3	3	4	4	4	4	-	-	

**0** Range 0 – White Spring Only (see below)

**1** Range 1 – Orange Spring (1 Spring)

**2** Range 2 – Orange and Gray Springs (2 Springs)

**3** Range 3 – Orange and Purple Springs (2 Springs)

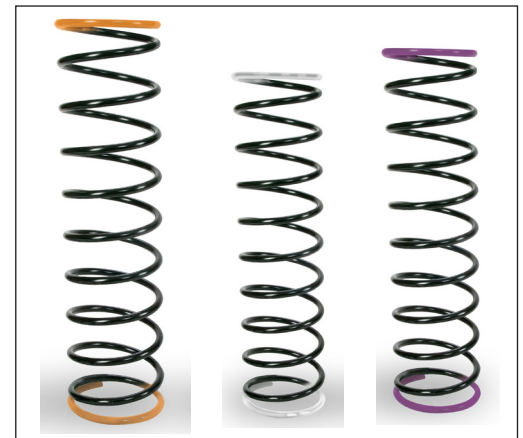
**4** Range 4 – Orange, Gray, and Purple Springs (3 Springs)

P3 All-Around comes complete with rotator ring, fork truck pockets in base and selected range spring package.

1. Fill in the weight of a fully loaded pallet here: \_\_\_\_\_  
(Do not guess. Get actual weight or have a pallet weighed)<sup>1</sup>

2. Fill in the height of a fully loaded pallet here: \_\_\_\_\_  
(Do not guess. Get actual height or measure a loaded pallet)<sup>1</sup>

3. Using the chart, select the correct PalletPal range: \_\_\_\_\_



P3 All-Around Spring springs are precisely calibrated and will work best within the load weight and height ranges selected. Selection based on higher or lower than actual weight will result in restricted raising or lowering capability. Should pallet weight or height requirements dramatically change, P3 All-Around Spring can be adapted in the field at any time by simply changing the spring combination used.

# Installation Instructions

## Unpacking the P3 All-Around Spring

1. Before you start to install the unit, check for local codes and ordinances which may apply. It is your responsibility to obtain any necessary permits.
2. Please read all of these instructions carefully. Be sure to read and understand all of the warnings.
3. Inspect the shipping pallet carefully for any damage which may have affected the unit. If you see signs of damage, tell the trucker. Also make a note of this on the shipping papers which you are asked to sign.
4. Choose the place where you want to use the unit. It is very important that the P3 All-Around Spring be set up on a smooth and flat surface. Check the floor surface carefully and make sure that it is free of all loose debris and dirt.

Using optional adjustable feet, the unit can compensate for a slightly sloping floor (1:25), but the surface must be smooth and solid.

### **CAUTION**

**The unit must be installed on a smooth flat surface. If the floor is not flat, this can create stresses in the frame of the unit. The unit may not work properly, or parts of the unit may wear more quickly than they should. You may be hurt or the load may be damaged.**

5. Position the P3 All-Around Spring beside the point where the unit will be set up.
6. Remove the banding which secures the unit to the pallet. Remove all packing material. Shift the unit to the floor. Support the base as you do this.
7. Check to see that the frame of the unit is sitting firmly on the floor. Try to move or rock the frame of the unit. The base frame should be stable, and should not move. Check to see that the base frame is level. (If any part of the frame is more than  $\frac{1}{2}$ " out of level in relation to any other part, you must install the optional adjustable feet to level the unit. See the instructions below.)
8. Remove the springs and lay them out on the floor.
9. If you have any questions about the steps in the installation process, please call Presto Customer Service at 1-800-343-9322.

## Setting up and Installing the Springs

1. The P3 All-Around Spring will always have at least one spring. This spring has an orange mark, and is larger in diameter than the others. This large orange spring is always placed in the front of the unit. Figure 3 shows the position of the first spring.

The frame of the unit can handle loads of up to 4500 lbs. In order to adapt the unit for different pallet loads, the springs are changed. The springs are chosen to match the weight and height of a fully loaded pallet. A unit may have one to three springs.

Each time the pallet weight or pallet height is changed, the springs may also need to be changed. Table 1 on page 10 show how the springs are selected.

2. The unit is shipped without springs installed. The installation of the first spring (orange) requires two people. Lift off rotating ring and both yellow bayonets. Set them aside, they will be installed later.

Fig. 3  
Orange Spring Installed



### **Optional Adjustable Feet**

Adjust each of the feet until the base frame of the P3 All-Around Spring unit is level. All four of the feet must touch the floor. Once the settings are correct, tighten the nuts against the mounting frame.

Fig. 4

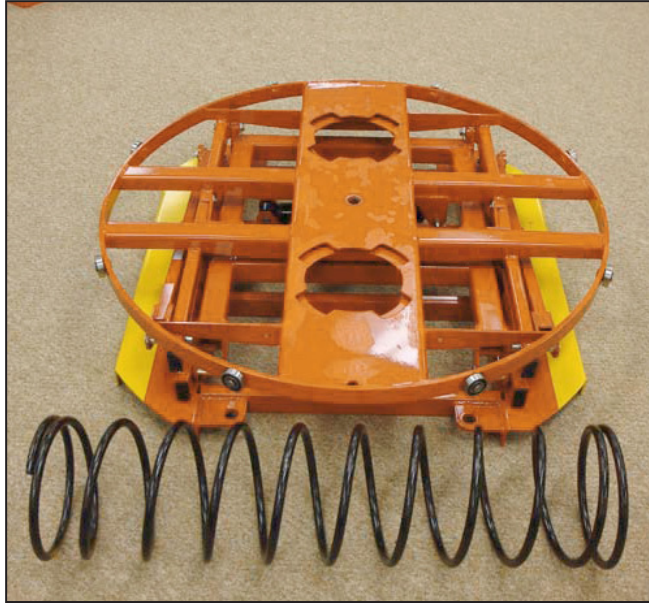


Fig. 5



3. The shock absorber is attached to the top frame of the unit with a pivot pin, and this is held in place by a linch pin. The pivot pint is used to hold the table frame in the raised position. Take a look at the mechanism and note the positions of the parts. Remove the linch pin and remove the pivot pin. Lay the free end of the shock absorber down.

Fig. 6



4. With the help of an assistant, lift the top frame until it hits the upper latch stops.



Fig. 7



5. While holding both latches up and lift the top frame pass the latches until it is at its full, upper most position. Have the assistant hold the weight and insert the pivot pin in the hole in the base frame. See Fig. 8. With the P3 All-Around Spring in this full upper most position the orange spring can be installed.

Fig. 8



Fig. 9



Alignment Tab

6. Insert either end of the large orange spring into the lower pocket. Be sure the bottom spring coil is positioned outside the alignment tab as shown.

Fig. 10



7. Grasp the spring by the second or third coil down from the top (do NOT grasp the top coil or rung) and push the spring down and under the edge of the top frame.

Fig. 11



8. While pushing down to compress spring push it forward into the pocket up under the top frame. It will "snap" into position when completely in the pocket.

Fig. 12



**CORRECT**  
Fully inserted into pocket

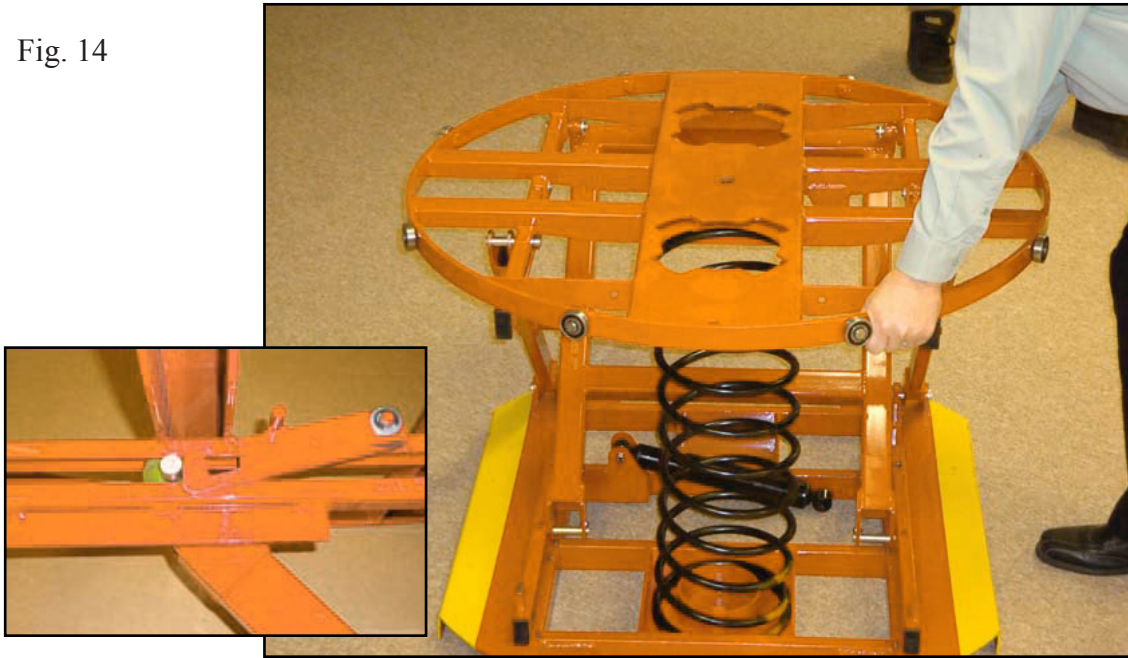
Fig. 13



**INCORRECT**  
Spring NOT fully inserted into pocket

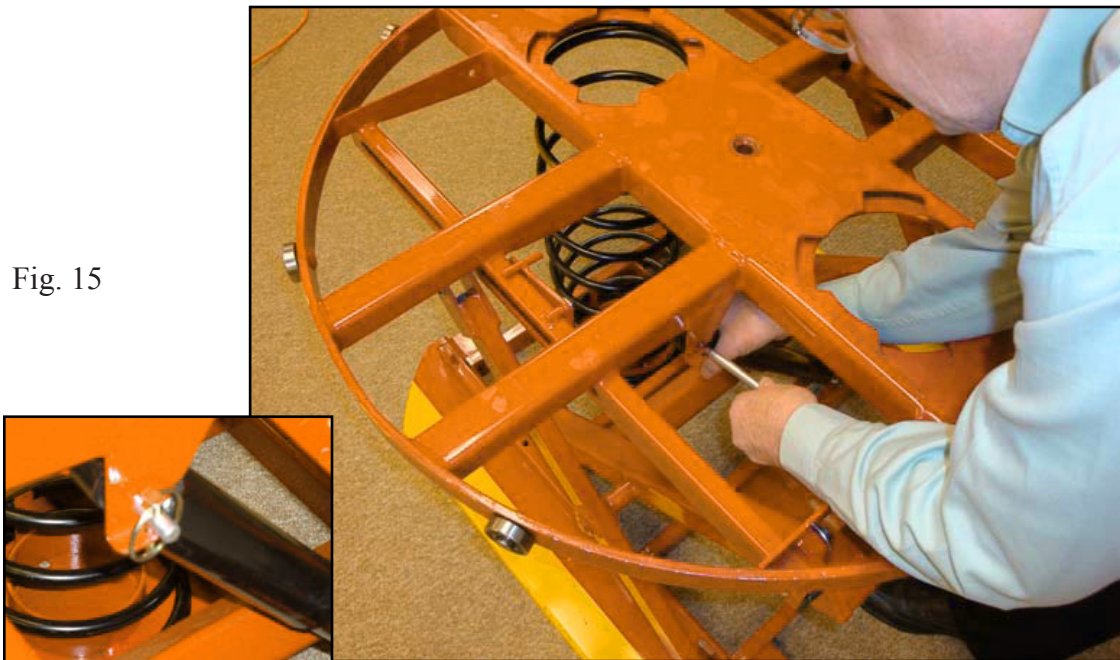


Fig. 14



9. Remove the shock absorber pivot pin. Push down on top frame until latches engage. (Both latches will drop into place).

Fig. 15



10. Reinstall the shock absorber pivot pin and lynch pin.





Fig. 16

11. Install additional springs as needed through the bayonet openings. Reinsert the yellow bayonets and twist to lock them in place.



Fig. 17

12. Reinstall the rotator ring.

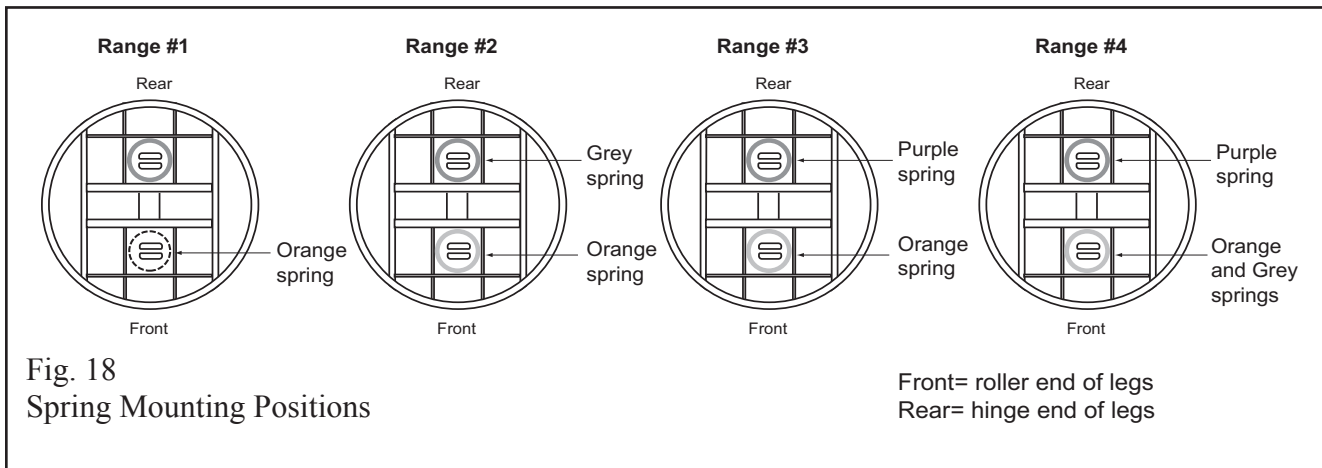


Fig. 18  
Spring Mounting Positions

13. Figure 4 shows the position of additional springs if needed. Double-check to be sure you have the correct springs. Refer to Table 1 on page 10 and see that you have the correct springs for your application.

Before using the unit, do a safety check. Be sure that each of the spring bayonet caps is in place and rotated to their locked position. Check the top and bottom of each spring to be sure it is seated correctly. Check the linch pin at the top of the shock absorber. These checks are very important.

**The P3 All-Around Spring is now ready for use!**

# Operating Instructions

## Loading Manually

Add boxes or parts until the pallet is full. Load the pallet in layers. Use the rotating ring to position the pallet to eliminate walking around. The unit will gradually lower the pallet until it reaches the bottom. See Fig. 19.

## Removing Loads Manually

Remove boxes or parts until the pallet is empty. Unload the pallet in layers. Use the rotating ring to position the pallet to eliminate walking around. The unit will gradually raise the pallet. See Fig. 20.

## Operating Safety - Manual Use

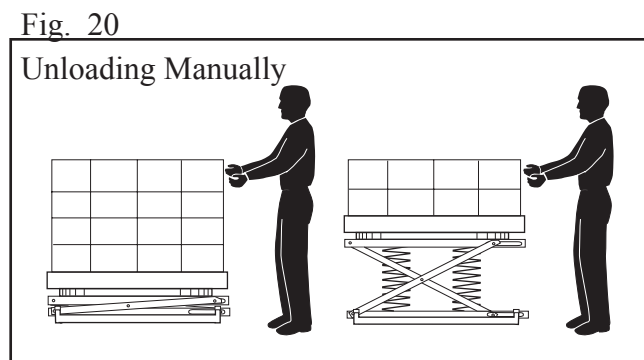
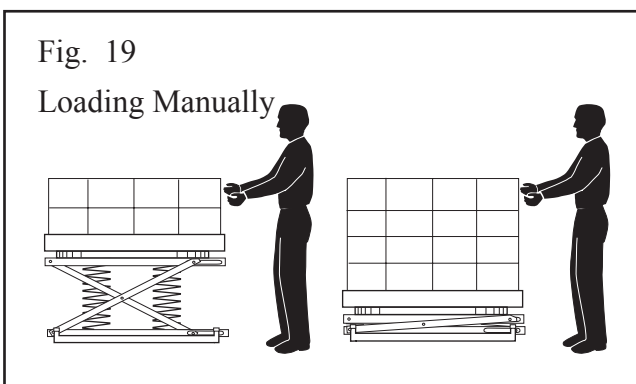
1. Do not use this unit with a load greater than the rated load. This includes the weight of the payload and the weight of the pallet. Table 1 on page 10 shows how to be sure you have the correct spring combination for your application.
2. Never push the load off of the side of the unit. If you do this, the frame of the unit may jump upward.
3. Never use the unit when anyone is sitting or riding on the rotating ring.
4. Do not try to use this unit with damaged or broken pallets. Broken pallets may have boards or nails which hang down below the main part of the pallet. As the pallet is turned, these boards or nails may catch on the frame. The pallet may stop turning suddenly and this can cause the load to shift. You may be injured and the unit may be damaged. If the boards or nails on the bottom of the pallet extend down more than  $\frac{1}{8}$  inch, they will interfere with the turning action.
5. Stay clear of the rotating ring when it is moving. As the pallet turns, a part of the load may rotate around and hit you.
6. Keep the area around the unit clean. Do not allow any dirt, debris, spilled oil, or excess grease to collect. These materials may cause you to slip while the unit is operating and you may be injured.

## Loading with a Fork Lift

1. Place the load on the lift, then lower the fork lift. Before removing the load, be sure the unit is carrying the weight, not the fork lift. See Fig. 21.
  - Lower the load until the springs on the P3 All-Around Spring are fully compressed.
  - Be sure the forks on the lift are clear of the inside of the pallet.

### **CAUTION**

**Rotate the pallet load. Never place your hands on the rotator ring. You may be hurt.**



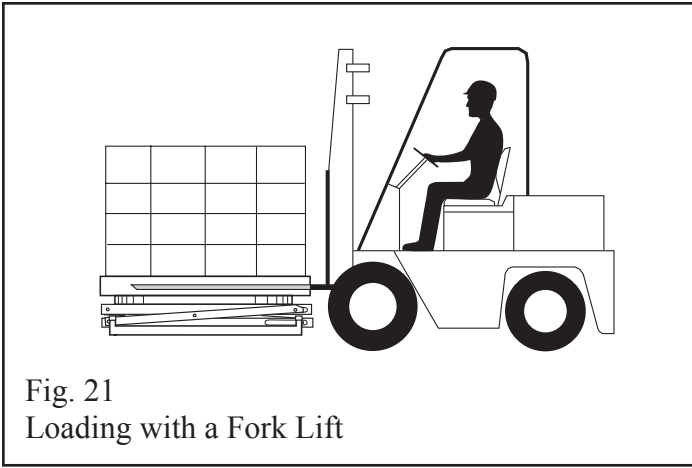


Fig. 21  
Loading with a Fork Lift

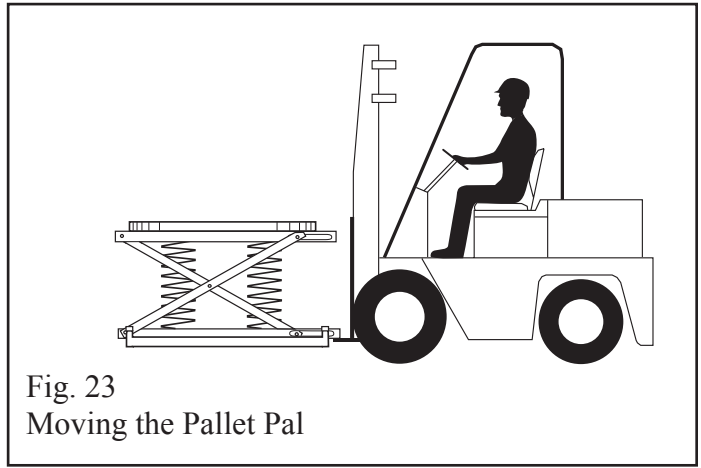


Fig. 23  
Moving the Pallet Pal

**WARNING!**

If you skip these steps, the load may drop suddenly when you remove the fork lift. You may be hurt or the unit or load may be damaged.

**WARNING!**

Never drop the load on the rotating ring. If you do this while the rotating ring is moving, the load may shift. You may be injured or the unit may be damaged. If you drop the load while the rotating ring is stopped, the unit may be damaged.

2. Be sure the load is centered on the unit.

**WARNING!**

If the load is off-center, it may shift when the rotating ring is turned. You may be hurt or the unit or load may be damaged.

**Unloading with a Fork Lift**

1. Insert the forks fully into the pallet, and lift the pallet straight up and clear of the top of the unit. See Fig. 22.

- Raise the pallet until the springs on the P3 All-Around Spring are fully extended.
- Be sure the pallet clears the top of the rotating ring before you move the fork lift.

**WARNING!**

If you skip these steps, the unit may jump up suddenly when you remove the pallet. You may be hurt or the unit or load may be damaged.

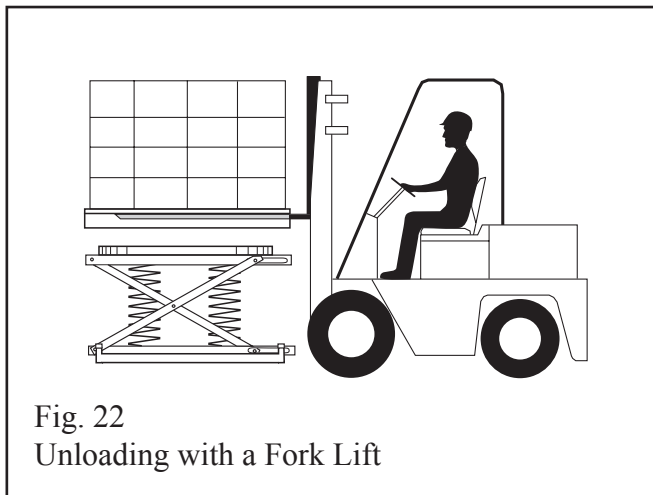


Fig. 22  
Unloading with a Fork Lift

**Moving the Pallet Pal**

**NOTICE**

Do not move the Pallet Pal while it is loaded. This will damage the base frame of the unit. The pockets on the base frame are designed to support an unloaded P3 All-Around Spring, but cannot support any extra weight.

1. Remove any load from the top of the Pallet Pal.
2. Insert the forks into the pockets in the base frame. See Fig. 23.

# Maintenance

## Routine Periodic Maintenance

Every 90 days -

### ⚠ WARNING

- As the lift moves up and down, "pinch points" are formed as shown in Figure 2. Keep hands, feet, and loose clothing away from these pinch points. If your hand or arm or a part of your clothing is caught, you may be hurt.
- A falling lift can cause severe personal injury. Before working under the lift remove any load from the platform and insert the maintenance device as described and shown on page 13, paragraph 5, figure 8.

- Check for loose hardware and signs of excessive wear. On the models where the shock absorber is used, check for signs of leakage.
- Check to be sure that the unit is placed on a firm level surface. If the optional feet are installed, be sure that all four feet are touching the floor and are locked in position.

# Troubleshooting

## Troubleshooting Check List

Problem	Possible Cause	Check This
The unit lowers too easily (too early).	The spring combination may be too weak for the load.	Check the spring ratings. See Table 1 on page 10.
The unit does not lower enough (too late).	The spring combination may be too strong for the load.	Check the spring ratings. See Table 1 on page 10.
The top of the unit rotates away from you.	The frame of the unit may not be level.	Move the unit to a level surface or install the optional adjusting feet.
The top of the unit bounces.	The shock absorber may be damaged.	Check for leaks or dents. Replace if damaged.
Excessive "rumble" when the ring rotates	Wear or lack of lubrication to bearings under rotating ring.	Remove turntable, lubricate or replace bearings.
Wear or metal flaking from underside of rotating ring.	Normal condition caused by work-hardening of metal.	No repair necessary. This will stop once the rotator ring wears in.

# Ordering Replacement Parts

Presto Lifts has carefully chosen the components in your unit to be the best available for the purpose. Replacement parts should be identical to the original equipment. Presto Lifts will not be responsible for equipment failures resulting from the use of incorrect replacement parts or from unauthorized modifications to the unit.

Presto Lifts can supply all replacement parts for your lift. With your order, please include the model number and the serial number of the unit. You can find these numbers on the name plate. This plate is located within the cabinet, or the angle iron cylinder cross support.

To order replacement parts, please call the Presto Parts Department. Parts are shipped subject to the following terms:

- FOB factory
- Returns only with the approval of our Parts Department.
- Credit cards preferred (except parts covered by warranty).
- Freight collect for truck (except parts covered by warranty).
- Freight - prepaid and invoice for small parcel shipments (except parts covered by warranty).
- The warranty for repair parts is 30 days from date of shipment.

Parts replaced under warranty are on a “charge-credit” basis. We will invoice you when we ship the replacement part, then credit you when you return the worn or damaged part, and we verify that it is covered by our warranty. Labor is not covered under warranty for Parts orders.

Presto Lifts Parts Department  
50 Commerce Way, Norton, MA 02766

Telephone: 800-343-9322  
FAX: 888-788-6496  
Email: [Service@PrestoLifts.com](mailto:Service@PrestoLifts.com)

**[www.PrestoLifts.com](http://www.PrestoLifts.com)**

# Presto Lifts Limited Warranty Policy

Presto Lifts warrants this product against defects in the welded structural frame and, including the scissor legs from sub-standard material and workmanship for a period of five years from the date of invoice.

All other components have a limited warranty against defects in faulty material and workmanship for a two year period from the date of invoice date of invoice and 30 day limited warranty on labor. Please note that prior authorization from Presto Lifts is required on all warranty work.

There are no implied warranties of any kind, more specifically, there are no warranties of merchantability or fitness for any particular purpose. Presto Lifts' sole warranty shall be as set forth in this limited warranty.

Presto Lifts will elect to repair or replace a defective component without charge, if any components should become defective within the limited warranty period. Proof of purchase is required for warranty. The charge for shipping the defective component is the responsibility of the buyer and must be accompanied with an RMA number. The shipping charge to return the component to the buyer is the responsibility of Presto Lifts, Inc.

This limited warranty does not cover labor expense for removal or reinstallation of components after thirty days. This limited warranty shall not cover, among other things: damages resulting from foreign matter or water, failure to provide reasonable and necessary maintenance or failure to follow operating instructions. The limited warranty is not valid for damage resulting from negligence, accident, unreasonable use, abuse or misuse, exceeding data plate capacities or altering the product without Presto Lifts authorization.

Presto Lifts expressly disclaims and excludes any liability for consequential, incidental, indirect or punitive damages or financial loss to people or property resulting from any breach of warranty or the operation or failure of this product.

Presto Lifts makes no representation that this product complies with local, state, or federal safety/product standards codes. Should this product fail to comply in any way with those codes, it shall not be considered a defect of materials or workmanship. Presto Lifts shall not be held liable for any damages resulting from noncompliance. It is the dealer's responsibility to exercise this limited warranty. This limited warranty is provided to the original purchaser (defined as the original end user) and is nontransferable. This constitutes the complete and final agreement involving Presto Lifts and limited warranty obligations for products.

MANY NEEDS REQUIRE MANY OPTIONS...

**Presto** LIFTS



LET PRESTO MEET THOSE NEEDS!

Call Presto Sales  
for stock or  
customized lift inquiries:  
**800-343-9322**

Email: [sales@prestolifts.com](mailto:sales@prestolifts.com)

