

# XZ Floor Level Lifts, TZ Floor Level Tilts & XZT Floor Level Lift & Tilts

## Installation, Operation and Service Manual

Model Number \_\_\_\_\_

Serial # \_\_\_\_\_

Date placed in service \_\_\_\_\_

**IMPORTANT: READ CAREFULLY  
BEFORE INSTALLING OR OPERATING LIFT**

Part orders are subject to a \$50 minimum charge.





**This label (part # 10095524)  
is required by California law.  
For more information visit  
[www.P65Warnings.ca.gov](http://www.P65Warnings.ca.gov).**

# Presto Lifts Limited Warranty Policy

Presto Lifts warrants this product to be free from defects in material or workmanship for the duration of the warranty period. Warranty periods vary and begin on the date of shipment. For specific warranty information, contact Presto Lifts with the machine's serial number.

Any claim for breach of this warranty must be received in writing by Presto Lifts within the warranty period. Warranties shall not cover failure or defective operation, caused by misuse, misapplication, negligence or accident, exceeding recommended capacities, or any alteration or repair of the item purchased which has not been authorized by Presto Lifts. Except as set forth herein, Presto Lifts makes no other warranties, express or implied, including THE WARRANTIES OF MERCHANTABILITY AND OF FITNESS FOR A PARTICULAR PURPOSE, all of which ARE HEREBY EXCLUDED.

Presto Lifts meets the labeling requirements of California's Proposition 65. Presto Lifts makes no warranty or representation with respect to the compliance of any product with other State or local safety or product standard codes and any failure to comply with such codes shall not be considered a defect of material or workmanship under this warranty. Presto Lifts shall not be liable for any direct or consequential damages arising out of such non-compliance.

Presto Lifts' obligations under any warranty or for any other damages which may arise under any sale, agreement, or contract, are limited to the replacement or repair of defective components at its factory or another location at Presto Lifts' discretion. This is buyer's sole remedy under any such warranty, sale, agreement, or contract. Presto Lifts will not be liable for consequential, incidental, exemplary, or punitive damages of any kind resulting from a breach of any warranty that it has provided or for breach of any term of any sale, agreement, or contract. Any warranty may be altered only in writing by Presto Lifts.

All commodities, software, or technology purchased from Presto Lifts are subject to the export and re-export control laws and regulations of the United States, including but not limited to the Export Administration Regulations ("EAR") and Department of the Treasury Office of Foreign Asset Controls ("OFAC") Regulations. Presto Lifts expects all distributors and customers to comply with these laws and regulations. Without limiting the foregoing, the distributor/customer cannot, without proper authorization from the applicable United States Government Agency, export, re-export, or transfer any commodity, software, or technology purchased from Presto Lifts, either directly or indirectly, to any entity, country, or national of any country in breach of such laws and regulations. Furthermore, Presto Lifts expects that the distributor/customer shall indemnify and hold harmless Presto Lifts from and against any claim, proceeding, action, fine, loss, cost and damages arising out of or relating to any noncompliance with export control regulations by distributor/customer, and distributor/customer are expected to compensate Presto Lifts for all losses and expenses resulting thereof, unless such noncompliance was clearly not caused by fault of the distributor/customer.

# CONTENTS

WARRANTY .....	4
<b>SECTION 1: Introduction</b> .....	5
Responsibility of Owners and Users.....	6
<b>SECTION 2: Safety</b> .....	7
Safety Alert Symbols and Signal Words .....	9
<b>SECTION 3: Installation</b> .....	10
A. Inspection.....	10
B. Installing.....	10
C. Electricals.....	10
D. Hydraulics.....	11
<b>SECTION 4: Operation</b> .....	11
<b>SECTION 5: Maintenance</b> .....	13
A. Routine Inspection and Maintenance .....	13
B. Chocking Procedures.....	13
C. Troubleshooting Maintenance .....	14
<b>SECTION 6: Service</b> .....	15-16
ORDERING REPLACEMENT PARTS .....	31
LABEL LOCATIONS.....	32
RESTOCKING POLICY & RMA POLICY.....	33 & 34
<b>LIST OF FIGURES:</b>	
Chocking Procedures XZ .....	Figure 1
Chocking Procedures TZ.....	Figure 2
TZ Pinch Points .....	Figure 3
XZ Pinch Points.....	Figure 4 & 5
Electrical Schematic 115 Volt AC, 1 Phase .....	Figure 6
Electrical Schematic 208-480 Volt, AC 3 Phase.....	Figure 7
Hydraulic Schematic .....	Figure 8
Electrical Schematic XLT 115.....	Figure 9
Electrical Schematic XLT 208-48 3 phase .....	Figure 10
Hydraulic Parts Layout.....	Figure 11
Hydraulic Schematic XLT .....	Figure 12
Replacement Parts for XLT .....	Figure 13
XZT HPU mounted on stand.....	Figure 14
Hydraulic Parts Layout.....	Figure 15a & 15b
XLT with Up/Down Alarm Pedestal Control .....	Figure 16
XZ Labels and locations.....	Figure 17

## **SECTION 1**

# **INTRODUCTION**

The Presto XZ and TZ Series Lift models are designed for lifting and/or tilting and positioning a wide variety of loads. Each lift is provided with an entrance ramp allowing easy access to the lift and also acts as a safety toe bar for the operator during the lowering cycle. The XZ and TZ Series Lifts are designed for indoor non-hazardous location use.

This manual provides information necessary for the safe and proper installation, operation and maintenance of these lifts. It is important that this manual be read by all personnel involved with the installation, maintenance or operation of the scissor lift. Where unique situations arise, which are not covered in this manual, contact Presto Lifts, Inc. for further instructions. Additional manuals are available upon request.

The floor level lifts have a nameplate that provides the load capacity ratings, serial number and model identification. Please refer to these numbers when ordering parts or requesting further information.



**Hazard or unsafe practice possibly resulting in personal injury or property damage.**

# Responsibility of Owners and Users

## **Inspection and Maintenance**

The device shall be inspected and maintained in proper working order in accordance with Presto's owner's manual.

## **Removal from Service**

Any device not in safe operating condition such as, but not limited to, excessive leakage, missing rollers, pins, or fasteners, any bent or cracked structural members, cut or frayed electric, hydraulic, or pneumatic lines, damaged or malfunctioning controls or safety devices, etc. shall be removed from service until it is repaired to the original manufacturer's standards.

## **Repairs**

All repairs shall be made by qualified personnel in conformance with Presto's instructions.

## **Operators**

Only trained personnel and authorized personnel shall be permitted to operate PowerStak.

## **Before Operation**

Before using the device, the operator shall have:

- Read and/or had explained, and understood, the manufacturer's operating instructions and safety rules.
- Inspected the device for proper operation and condition. Any suspect item shall be carefully examined and a determination made by a qualified person as to whether it constitutes a hazard. All items not in conformance with Presto's specification shall be corrected before further use of the PowerStak.

## **During Operation**

The device shall only be used in accordance with this owner's manual.

- Do not overload.
- Ensure that all safety devices are operational and in place.

## **Modifications or Alterations**


Modifications or alterations to any Presto industrial positioning equipment shall be made only with written permission from Presto.


## **SECTION 2**

### **SAFETY**

The XZ and TZ Series lifts are very powerful lifts capable of doing large amounts of work. They are hydraulically actuated and capable of causing serious injury or damage if adequate precautions are not taken. **DO NOT INSTALL OR OPERATE THESE LIFTS WITHOUT CAREFULLY READING THIS MANUAL.** Presto Lifts, Inc. has identified certain hazards which may occur during the installation, maintenance and use of these lifts.

The TZ Lifts are serviced or repaired in the collapsed position. The XZ lifts are serviced in a raised position supported by safety devices. When the maintenance is performed properly according to Sections 5 and 6, it will greatly reduce the possibility of injury. Both the XZ and TZ lifts have hydraulic safety fuses attached to each cylinder. These will prevent the lifts from lowering in the event of a catastrophic hydraulic pump or line failure.

 **DANGER** - Immediate hazard that will result in severe personal injury or death.

 **WARNING** - Hazard or unsafe practice that could result in severe personal injury or death.

 **CAUTION** - hazard or unsafe practice that could result in minor personal injury or property damage.

**In the interest of safety, please read the entire manual carefully. You must understand the material in this manual before you install, use, or service the unit. If you have any question about any of the instructions in this manual, please contact Presto Lifts Inc. at 1-800-343-9322.**



**Do not perform any repair work on a lift in a fully extended position.**

**All personnel must stand clear of the lift when the lift is in motion.**

**Do not put hands or feet under lift.**

**Do not work under lift without securing it first with proper maintenance devices.**

**Do not stand, sit or climb on the lift at any time.**

**Do not use the lift on soft, uneven or unstable surfaces.**

**Do not exceed the load capacity rating on the data plate.**

**Do not place a load on a moving lift.**

**Place a load in the center of the lift and be sure that the load is secured properly.**



# SAFETY ALERT SYMBOLS AND SIGNAL WORDS

The safety of all persons operating, maintaining, repairing, or in the vicinity of this equipment is of paramount concern. This is a powerful machine with moving parts, and is capable of causing personal injury if proper precautions are not taken. Therefore, throughout this manual, certain hazards have been identified which may occur in the use of the machine, and there are appropriate instructions or precautions which should be taken to avoid these hazards. In some cases, there are consequences which may occur if instructions or precautions are not followed. Below are the symbols and signal words along with their definitions referenced from ANSI Z535.4 - Product Safety Signs and Labels.

## Safety Alert Symbols

These are the safety alert symbols. They are used to alert you to potential physical injury hazards. Obey all safety messages that follow this symbol to avoid possible injury or death.



**For use with DANGER signal word**  
(Red Background)



**For use with WARNING signal word**  
(Orange Background)



**For use with CAUTION signal word**  
(Yellow Background)

## Signal Words

The meaning of different signal words as defined by ANSI Standard Z535.4 indicates the relative seriousness of the hazardous situation.



(Red Background)

DANGER indicates a hazardous situation which, if not avoided, will result in death or serious injury.



(Orange Background)

WARNING indicates a hazardous situation which, if not avoided, could result in death or serious injury.



(Yellow Background)

CAUTION, used with the safety alert symbol, indicates a hazardous situation which, if not avoided, could result in minor or moderate injury.



(Blue Background)

NOTICE is used to address practices not related to personal injury.



(Green Background)

SAFETY INSTRUCTIONS (or equivalent) signs indicate safety-related instructions or procedures.

## **SECTION 3**

# **INSTALLATION**

### **A. INSPECTION:**

Inspect the lift completely to determine if there is any damage that occurred during shipment and that the lift is complete. Do not use the lift if there appears to be any damage. Check the following with the lift in the collapsed position:

1. Check for signs of damage to the electrical and hydraulic components of the remote power pack. Check the hydraulic hoses going to the lift and the hydraulic components on the lift.
2. Check all connections for tightness. Check for visible hydraulic fluid around all components of the lift and power pack or on the floor nearby.
3. Check base frames for flatness and for bent or damaged metal parts.
4. Inspect the lifting eyes making sure they are completely threaded into the nuts provided on the lift and the locking nut is secured.

### **B. INSTALLING:**

Make sure that the electrical system is wired correctly and that there is full compliance with the local electrical codes and ordinances.



**These lifts require bolting to the floor before operation.**

1. Floor Installation
  - a. Make sure that the floor in the installation area is flat, stable, relatively smooth and free from dirt, obstacles or surface defects.
  - b. Place the lift in the exact operating position using a sling attached to all four lifting eyes.



**When moving the lift never ever attempt to pick it up by the corners or the base. The lift should be picked up only by the lifting eyes. The use of a spreader strap/sling is suggested. Be sure that the eye bolts are secured in place with locking nuts prior to lifting.**

- c. Make sure that the complete base of the lift is in contact with the floor. In order to provide complete contact with the floor, the base may be shimmed or grouted.



**Do not spot shim. The complete base must be in contact with the floor. Shim to have continuous contact of base and floor.**

- d. The lift is provided with lag plates or brackets. Place the lift in the exact operating position before spotting or drilling holes for the bolts. Bolt the lift securely using at least four (4) large bolts with a minimum of 2,000 lb. Pull out strength per bolt.
- e. All XZ and TZ lifts have a remote power pack that is hydraulically connected to the lift at the factory. Be sure all hydraulic reconnections are made according to the information contained in Section 3; paragraph D3.
- f. Electrical connections must be made according to the electrical schematics and information contained in Section 3C, and in compliance with local codes and ordinances.

### **C. ELECTRICALS:**

1. The motors on the XZ and TZ power pack are intermittent duty motors with high pull up torque.



**All wiring must conform to local code and must be performed by licensed electricians. The standard AC single phase motor requires a 120 volt 20 amp fused outlet, do not remove or replace the plug or cord set provided. Do not use an extension cord.**

2. The following chart recommends the power source for various motors supplied with the XZ and TZ lifts:

<b>AC Motor Size</b>	<b>Fuse</b>	<b>Breaker</b>
1HP 120 Volt 1 PH	20 AMP	20 AMP
1HP 240 Volt 1 PH	15 AMP	15 AMP
1-1/2 HP 20S-240 Volt 3 PH	15 AMP	10 AMP
1-1/2 HP 460 Volt 3 PH	7-1/2 AMP	5 AMP

### 3. Wiring schematics for motors:

See Figure 8 for 115 Volts 1 PH

See Figure 9 for 208-480 Volts 3 PH

#### **⚠ WARNING**

**Do not tamper with or remove the cover for the electrical junction box. Only authorized qualified personnel are allowed to service the electrical system.**

#### **⚠ WARNING**

**Failure to make electrical connections according to nameplate ratings and wiring diagrams may lead to pump and motor failure. The 3 phase motor direction is most critical. The pumps can not be run backwards or in reverse for more than three (3) seconds. If lift does not rise immediately. STOP. Inspect connections for correct wiring and polarity.**

### D. HYDRAULICS:

1. Before using the lift, check the hydraulic oil level and add oil if necessary. Check fittings for tightness. Remove the solid plug on the reservoir and replace it with the vented plug provided. If the vented plug is not installed, you may damage the pump. Note: If the vented plug is not available, remove the solid plug and drill a 1/8" diameter hole through the center of the plug. Replace the plug.

2. Use hydraulic oil only for the lift. The lift has been supplied with Conoco Super Hydraulic 32. Use only the recommended oils listed in the hydraulic schematic located in the rear of this manual in Figure 10.

#### **⚠ WARNING**

**Do not use automotive hydraulic brake or transmission fluids. They will destroy the pump and cylinder seals. They pose a serious fire hazard.**

3. External power pack units are shipped connected. If disconnection is required during installations, the lines must be blown out and bled prior to being reconnected.

#### **⚠ CAUTION**

**The XZ and TZ lifts are designed for normal factory environments. Where below freezing temperatures sometimes exist, special oils must be used. Contact Presto Lifts, Inc. for information and recommendations when freezing conditions exist.**

### E. TESTING THE LIFT WITH NO LOAD:

1. Before testing the lift, clear the area of any loose material. Be sure the lift has no obstructions above it or on any side. Briefly operate the lift for 2-5 seconds. If the lift begins to rise with a humming sound and functions properly, continue to the full upright position.

#### **⚠ WARNING**

**If the lift does not rise immediately or there is any operational problem, stop it. Before continuing, check the rotation of the motor and the voltage at motor terminals. Again, briefly operate the lift. If the lift does not move smoothly with the humming sound, stop and review the procedures in Section 5C, Troubleshooting Maintenance.**

## SECTION 4

# OPERATION

### A. METHOD OF OPERATION:

All XZ and TZ lifts are provided with a relief valve and are factory preset to the maximum safe load capacity of the lift. Activating and holding the upswitch will energize the motor. The motor is attached to a positive displacement pump which draws hydraulic fluid from the reservoir and transfers it under pressure to the cylinders. This forces the ram forward and raises or tilts the platform. Releasing the up switch will stop the lift. A check valve built into the pump holds the lift in position. Depressing and holding the down switch of the switch will energize a solenoid which allows the oil from the cylinder to return to the reservoir through a pressure flow control valve and the pump. This allows the lift to lower smoothly and at a controlled factory preset speed.

**⚠ WARNING**

**Do not maintain the switches energized if the lift does not move or has reached its up or down limits. This may cause damage to the motor, pump and controls.**

**B. OPERATION PROCEDURES:**

In order to operate the lift, follow these operating procedures:

1. Read and understand all the instructions before operating. If the lift has modifications or accessories, read and understand their functions. Review Section 3E and Pinch Points figures 3, or 4 and 5.

2. Load the lift correctly.

- a. Do not exceed the maximum rated load capacity.  
The load capacity is marked on the data plate on the left.
- b. Place the load in the center and at the very back of the platform.
- c. If the load is unstable or may become unstable, fasten it into position.
- d. Use additional precautions when tilting a load of loose parts of the TZ lift. Excessive tilting can cause parts to roll out.

3. Operate the lift.

- a. To raise the lift, press and hold the up switch.
- b. To lower the lift, press the down switch.
- c. Release the switch to stop the lift in either direction.

4. Wait until the lift has come to a complete stop before loading or unloading.

5. All people and unrelated objects must stand clear of the lift when operating in order to avoid personal injury or property damage.

**⚠ WARNING**

**a. Do not load or unload a moving lift.**

**b. Stop immediately if the lift fails to move or**

**exhibits strange movements or sound. Do not continue to operate the lift until it has been checked and repaired.**

**c. When operating the lift, stand clear of the scissor legs and the platform.**

**d. Obey all warning labels.**

**e. Do not stand near the tilting side when tilting containers with loose parts. Parts may fall out of the container and could harm the operator.**

## SECTION 5

# MAINTENANCE

Generally, the XZ and TZ Series Lifts will require little maintenance. However, routine maintenance and inspection will minimize cost of repairs and hazardous conditions.

### **⚠ DANGER**

**Before servicing the lifts, read and understand this complete manual.**

**Never put any part of your body under the lift or service the lift with a load on the platform. If possible, service the lift in a down position.**

#### A. ROUTINE MAINTENANCE:

All routine maintenance should be performed monthly and can be performed monthly and can be performed in a lowered position. Before performing any maintenance, shut the power off and disconnect switches using lockout/tagout procedures. Perform the routine listed checks in 1a-1g.

### **⚠ WARNING**

**Safety Chocks and/or safety pins must be installed on the lift while maintenance is being performed on the lift if it is in a partially raised position. Follow chocking procedures in Section 5B. These chocks and/or pins are provided and are attached to the lift. Contact Presto Lifts, Inc. for the recommended parts, if yellow safety chocks are not available.**

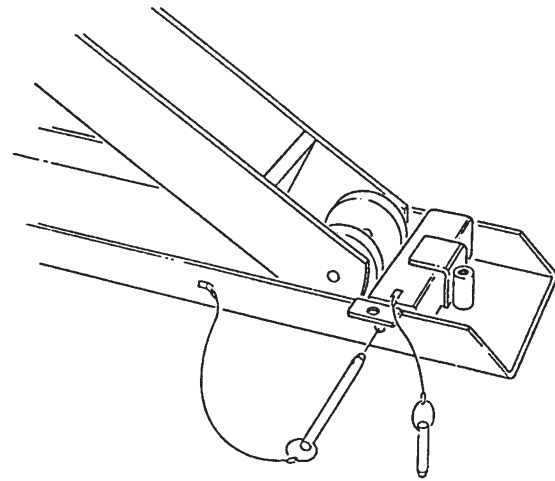
1. Inspect the following:
  - a. Check the reservoir oil level and add correct oil according to Figure 10, if necessary.
  - b. Check the rollers for sign of wear. Replace if damaged.
  - c. Check snap ring and shield on rollers. Replace if damaged.
  - d. Check hydraulic lines for damage or leaking. Replace if damaged.
  - e. Check for oil spots on the floor. Trace the leak to the proper fitting and tighten or replace.
  - f. Check wiring for damage. Replace immediately if any signs of wear are evident.

- g. Bearings on all lifts are permanently lubricated and require no servicing. Do not oil these bearings.

#### B. CHOCKING PROCEDURES:

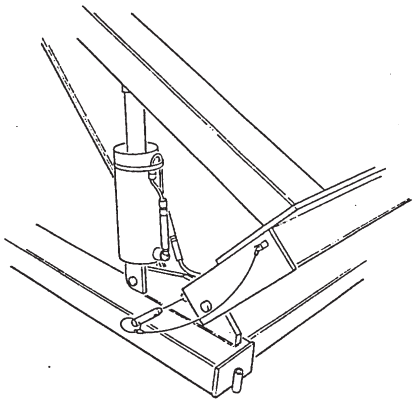
1. Raise the lift to its maximum height.

### **NOTE: XZ Prior to 2005**



**FIGURE 1: Chocking Procedures XZ**

2. Using only the chock assembly provided, place the square tubing in the wheel tray sideways and adjacent to the welded long lifting eye nut.
3. Insert the pin which is secured to the lift through the holes provided in the wheel tray. Be sure the pin enters both holes and through the center of the tubing.
4. Lower the lift until the wheels come in contact with the chock and hold the “down” button for another 2 seconds.
5. Perform routine maintenance according to Section 5A.
6. Raise lift, remove and replace chock to its straight position.



**FIGURE 2: Chocking Procedures TZ**

1. Raise the empty lift to its maximum height.
2. Using only the safety chock pin provided, insert the pin in the hole in the pivot block.
3. Be sure the pin extends through the block 1/2" beyond the pivot block.

### C. TROUBLESHOOTING MAINTENANCE:

All servicing should be done by qualified personnel who have read and understand all of the information provided in the Operating, Installation and Maintenance sections of this manual.

#### LIFT WILL NOT MOVE

1. Lift will not raise or tilt:
  - a. Check the power switch, fuses, overloads and breaker.
  - b. Check the voltage at motor; motor may have failed.
2. Operational noises, erratic or noisy performance.
  - a. Lift may be overloaded or jammed. Check load weights and obstructions (see nameplate for capacity).
  - b. Motor (3 phase) single phasing. Check voltage at motor terminals.
  - c. Motor (3 phase) reversed.
  - d. Motor (1 phase) low voltage. Check voltage at motor terminal.
  - e. Oil shortage: Reservoir low or oil line failure. Repair or replace.
  - f. Down valve open: check wiring for damage. Remove and replace if necessary.

3. Motor overheats:
  - a. Excessive cycle rates (15 cycles per hour max.)  
Check actual time in use.
  - b. Low voltage: Check voltage at motors.
  - c. Oil starvation: Check filter in reservoir.

#### LIFT OPERATING SLOWLY

1. Up cycle:
  - a. Oil starvation: Check filter in reservoir. Check for pinched hydraulic lines.
  - b. Oil viscosity: Oil is too heavy or too thin.
  - c. Air in cylinder: Cycle lift with no load, 2 or 3 times and depress the "up" switch for 5 seconds after reaching maximum height on each cycle.
2. Down Cycle:
  - a. Down solenoid valve filter dirty: Remove and clean.
  - b. Check oil condition: Replace if dirty.
  - c. Oil viscosity is too heavy: Replace.
3. Lift raises, then slowly lowers without power:
  - a. Leaking hydraulic lines or fittings: Check for tell-tale oil spots.
  - b. Pump check valve in pump may be inoperative: Pump must be replaced.
4. Lift will not lower when energized:
  - a. Down solenoid faulty: Check voltage; may be low or wrong voltage for coil or coil may be wrong voltage for secondary voltage.
  - b. Check continuity of coil: Could be burned out.

## **SECTION 6**

# **SERVICE**

### **A. ORDERING REPLACEMENT PARTS:**

1. Standard replacement parts for each lift are provided by part number and lift models, see Figure 6.
2. All key parts are identified and must be replaced with original equipment components.
3. The warranty is void where original equipment components are not used.
4. Be sure to have the serial number and the model number of the lift available when you are requesting replacement parts.

### **B. REPLACING CYLINDER SEALS:**

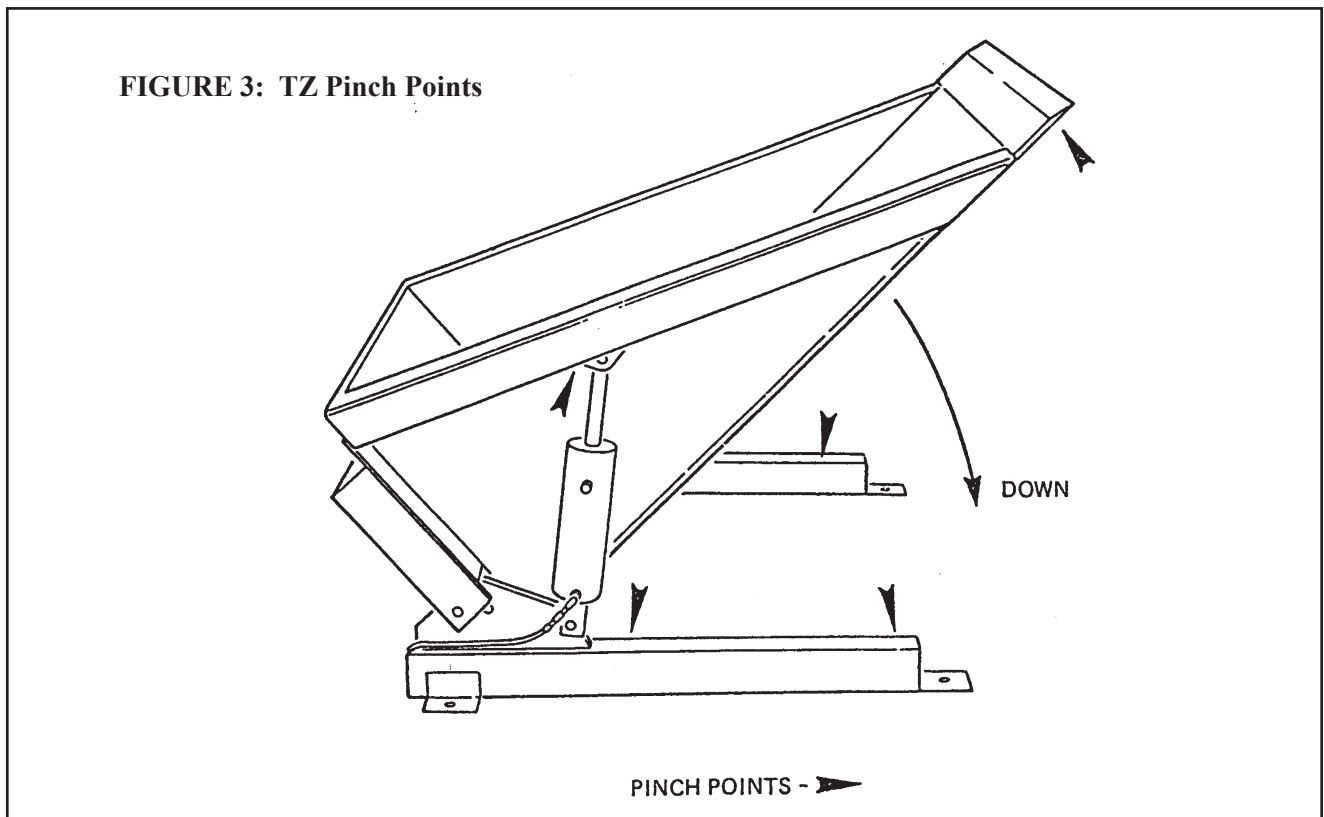
1. Raise the lift. Chock the lift with safety chocks provided and secure per Section 5B.
2. Disconnect the electrical power.

3. Disconnect the hydraulic hose from the cylinder and cap the line to prevent hydraulic fluid loss.
4. Remove the cylinder pin by loosening the set screws holding the pin. Remove the bolt holding the cylinder base.
5. Lift the cylinder out of the lift.



**Hold the cylinder securely when removing the pins to prevent it from falling to the floor and being damaged.**

6. Clamp cylinder securely at the base end.
7. Completely collapse cylinder piston.
8. Push gland into the cylinder 1/8" – 3/16".
9. Remove retainer ring.
10. Remove piston ram, piston and gland from cylinder.
11. Remove ram nut, piston and gland.



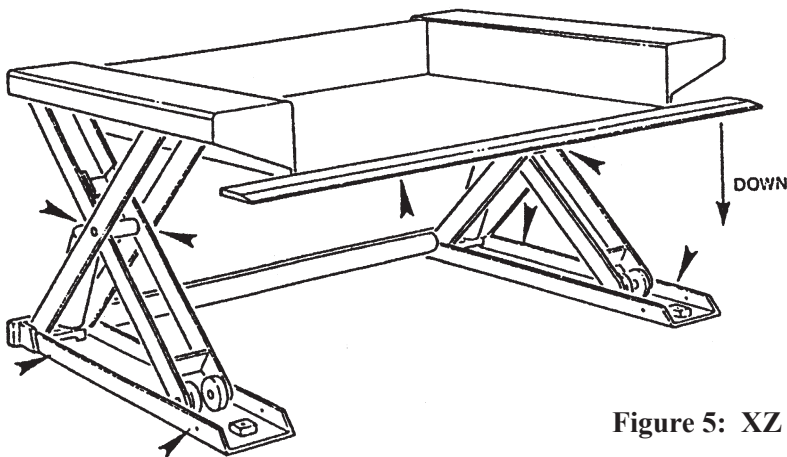
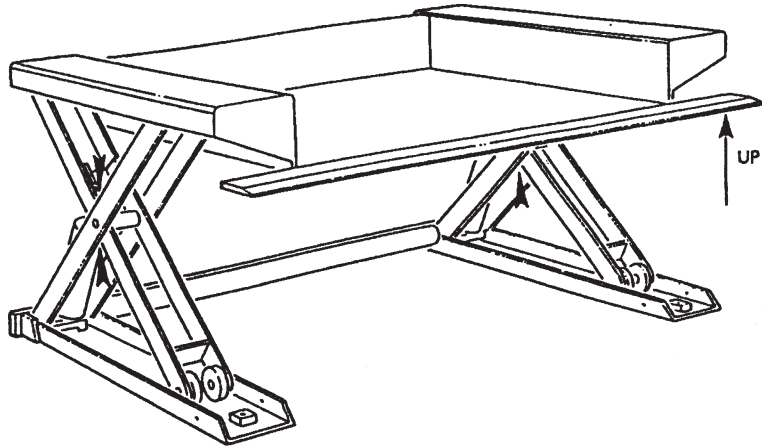
12. Remove and replace seals and wipers.
13. Assemble piston and gland to piston ram.
14. Assemble ram nut to piston ram and torque to 100 ft/lb.
15. Lubricate piston and seals and install cylinder.
16. Insert retainer ring.
17. Install cylinder and hydraulic lines.
18. Fill reservoir.
19. Cycle lift up and down a few inches, remove

chocks, cycle lift 2-3 times and recheck oil reservoir for oil level.

### C. REPLACING LEG ROLLERS ON XZ LIFT:

1. Raise the lift. Chock lift with safety chocks provided and secure per Section 5B.
2. Disconnect the electrical power.
3. Replace one roller at a time by removing retainer clips, shields and roller. Clean and do not lubricate axle. Replace with new rollers, shields and clips.
4. Raise lift and remove chocks. Cycle lift 2-3 times and check shields and clips prior to returning to service.

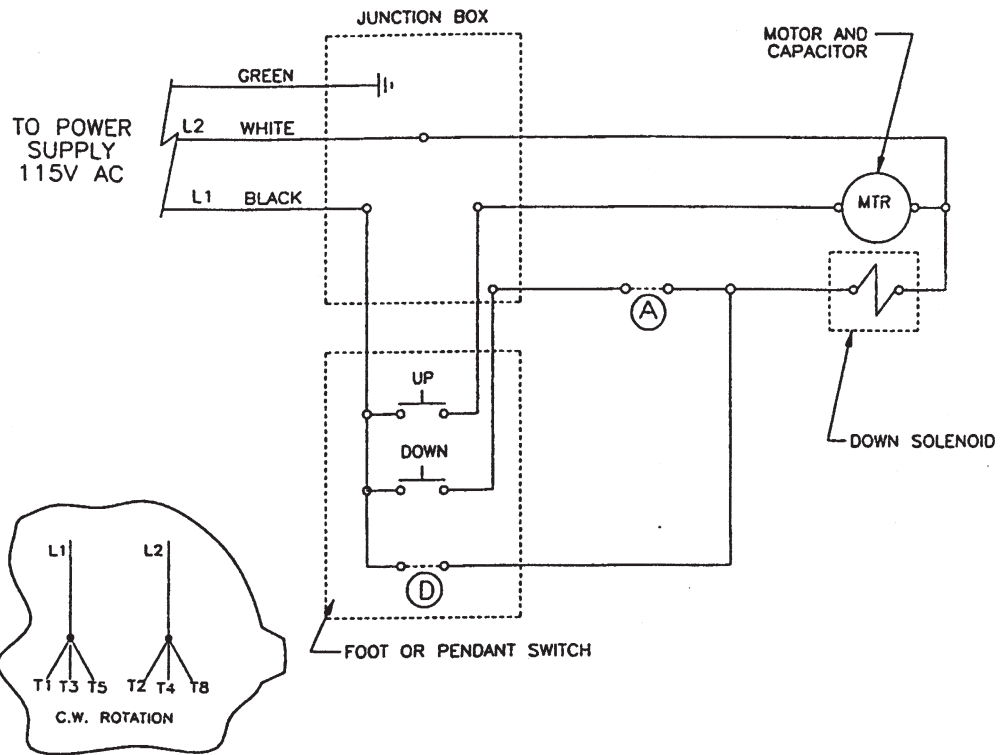
**FIGURE 4: XZ Pinch Points, UP**



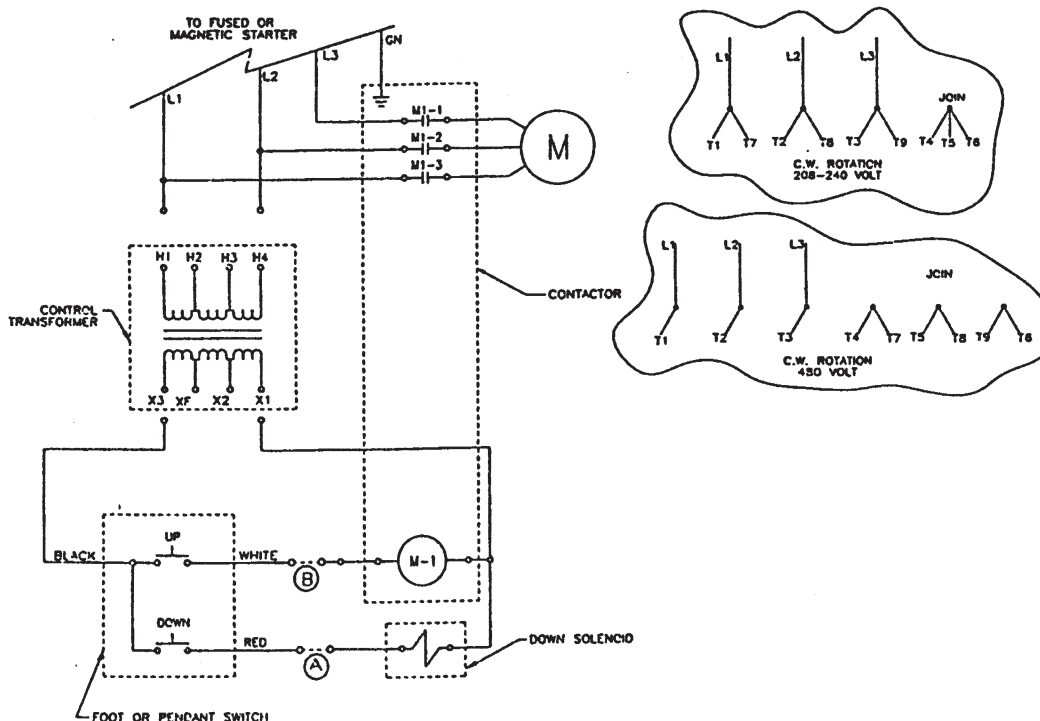
**Figure 5: XZ Pinch Points, DOWN**



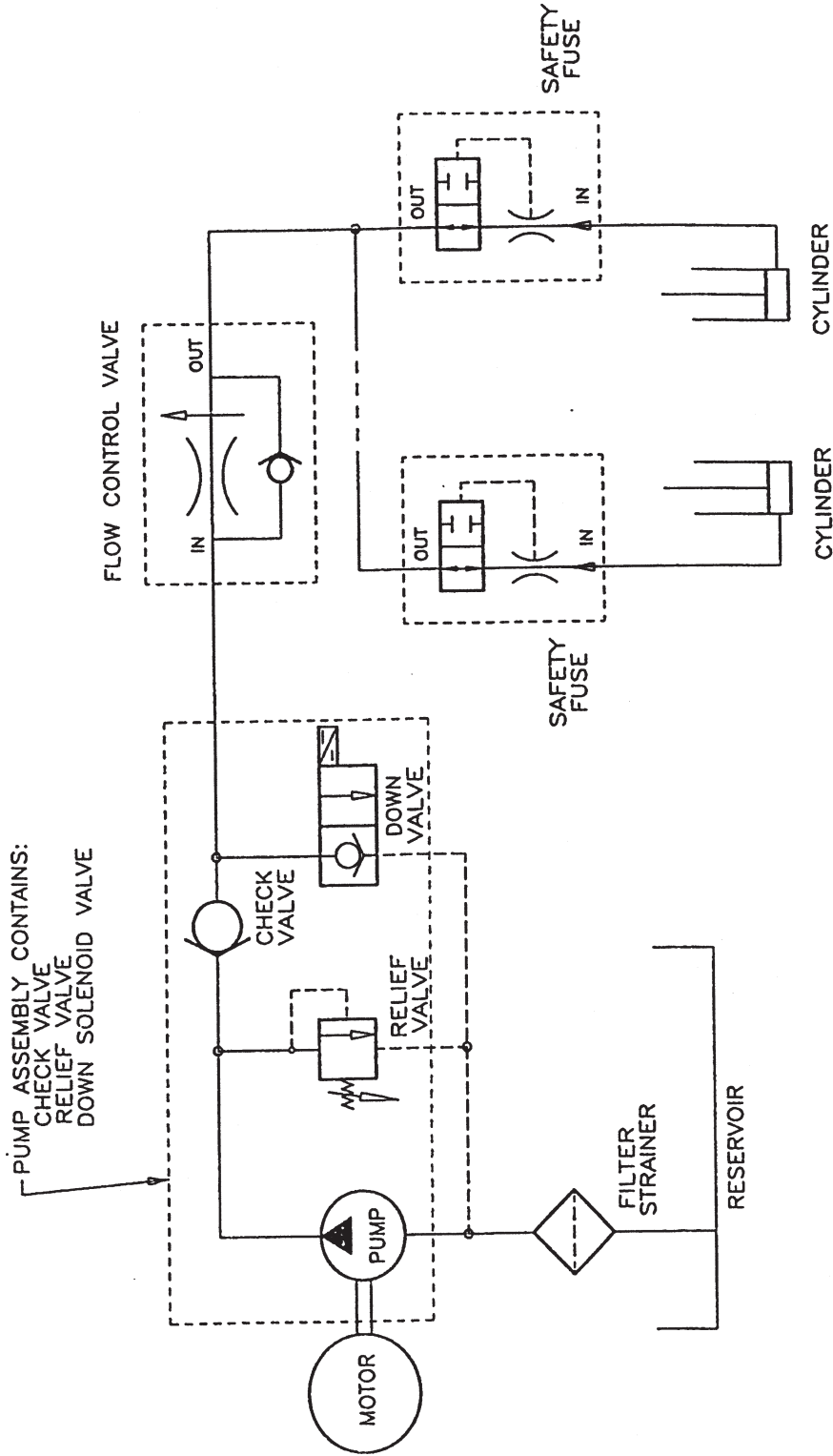
**Figure 6: Electrical Schematic 115 Volt AC, 1 Phase XZ & TZ**



**Figure 7: Electrical Schematic 208, 220, 460 Volt AC, 3 Phase ZX & TZ**

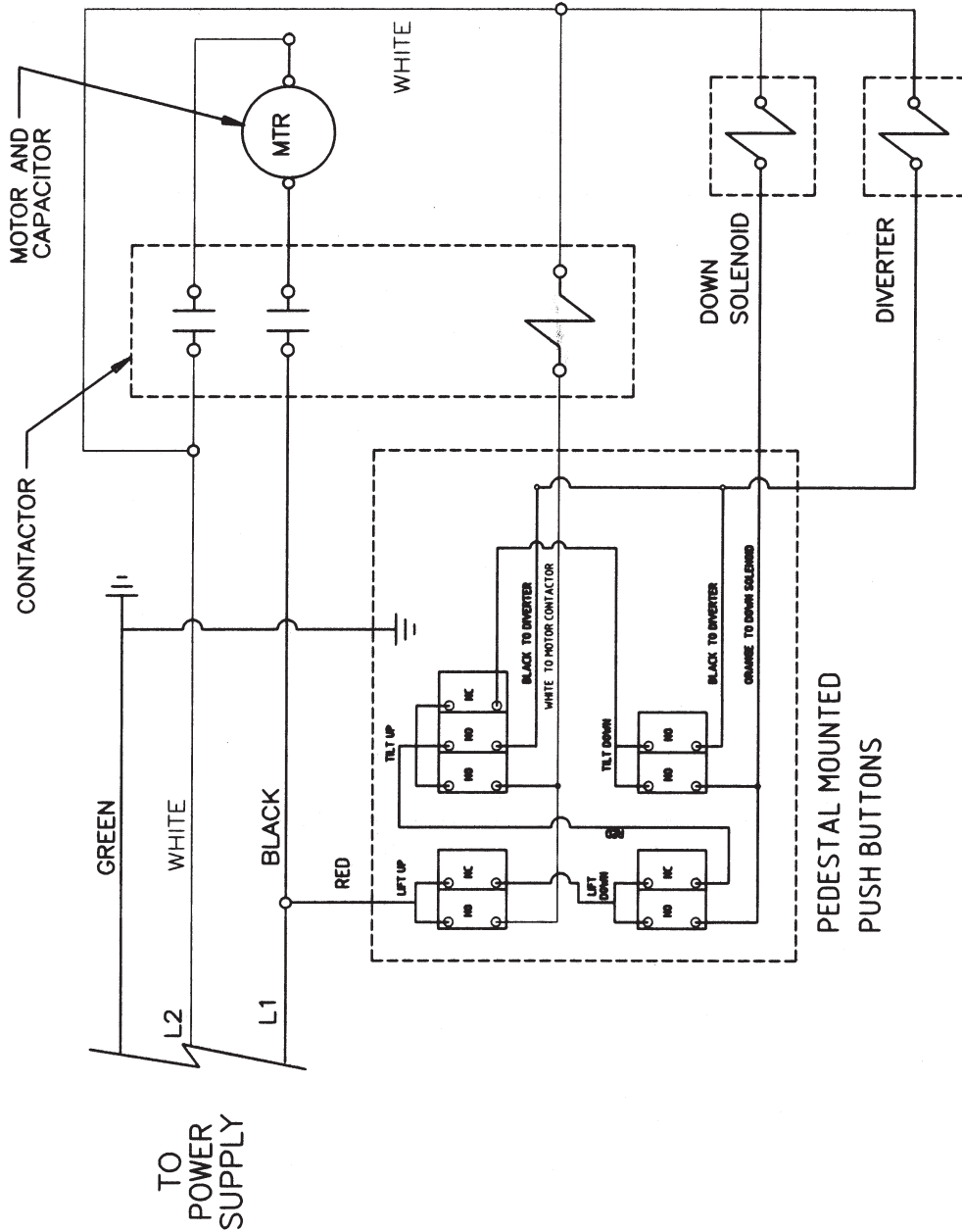


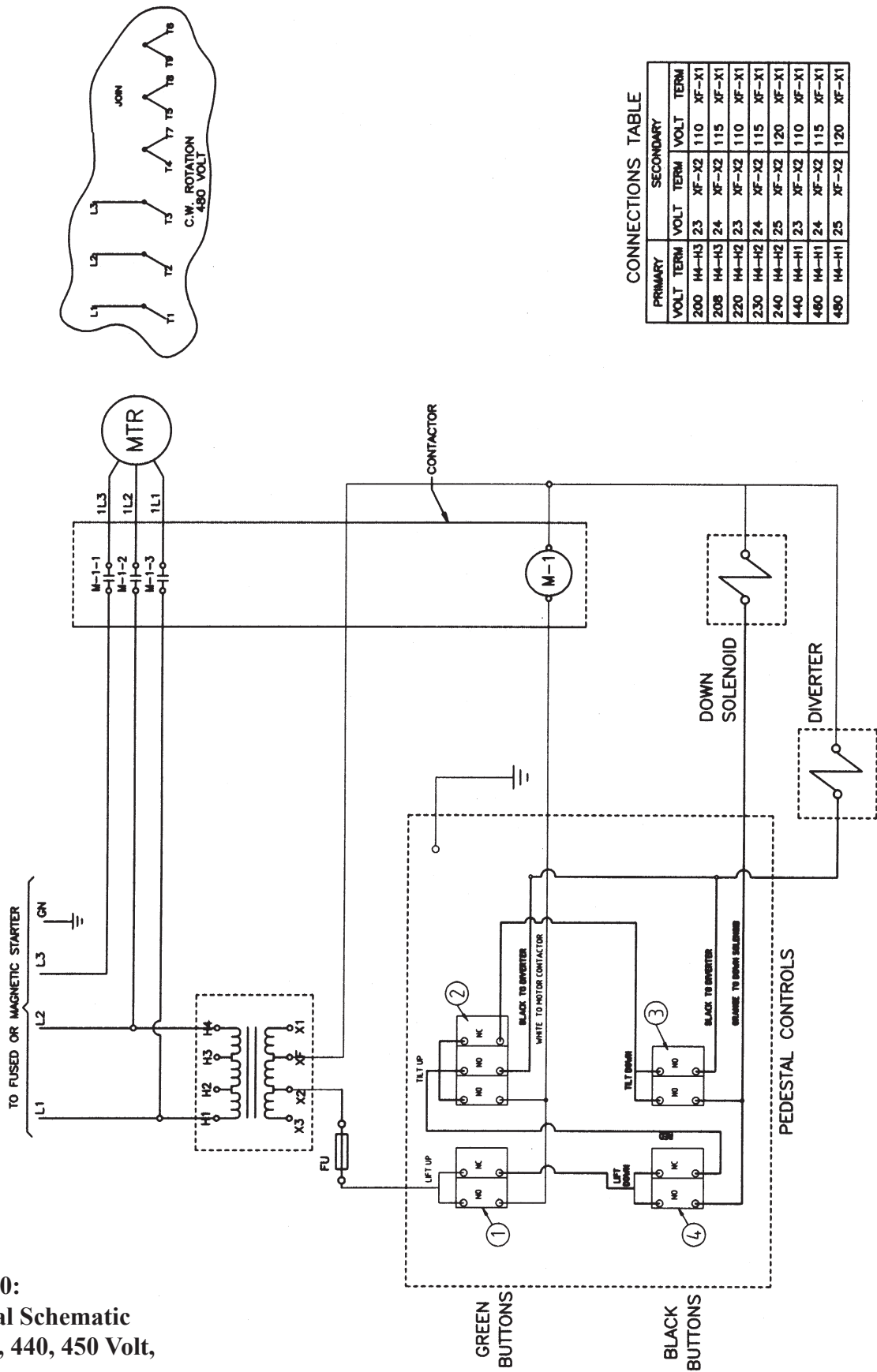
**Figure 8: Hydraulic Schematic**



USE ONLY PREMIUM HYDRAULIC OIL  
 ISO GRADE 46 WHICH HAS,  
 RUST & OXIDATION INHIBITORS,  
 WITH ANTIWEAR & ANTIFOAMANT AGENT.

Figure 9: Electrical Schematic 115 Volt, AC 1 Phase



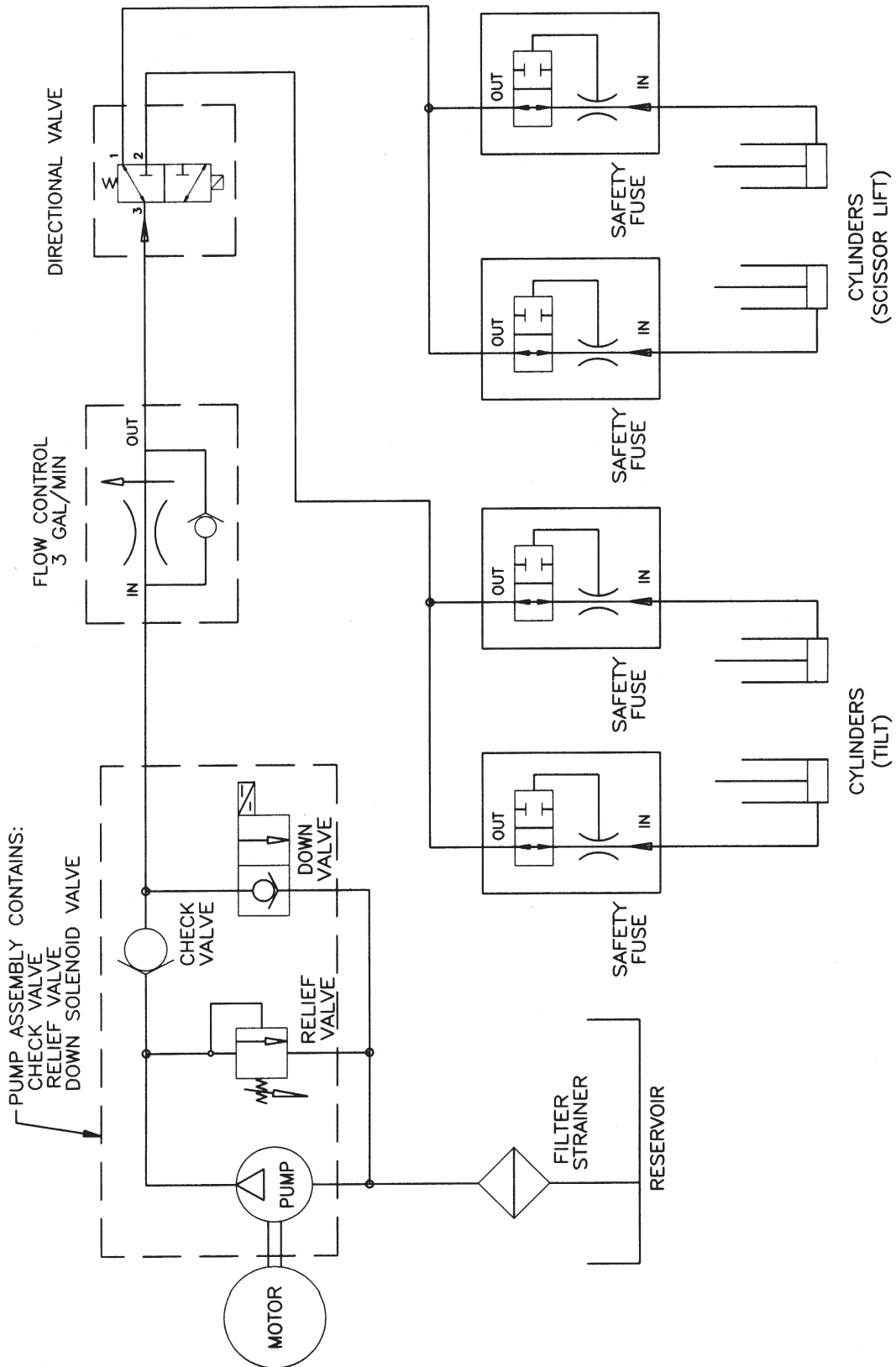


**CONNECTIONS TABLE**

PRIMARY VOLT TERM	SECONDARY VOLT TERM	VOLT	TERM
200	H4-H3	23	XF-X1
208	H4-H3	24	XF-X2
220	H4-H2	23	XF-X2
230	H4-H2	24	XF-X2
240	H4-H2	25	XF-X2
440	H4-H1	23	XF-X2
460	H4-H1	24	XF-X2
480	H4-H1	25	XF-X2

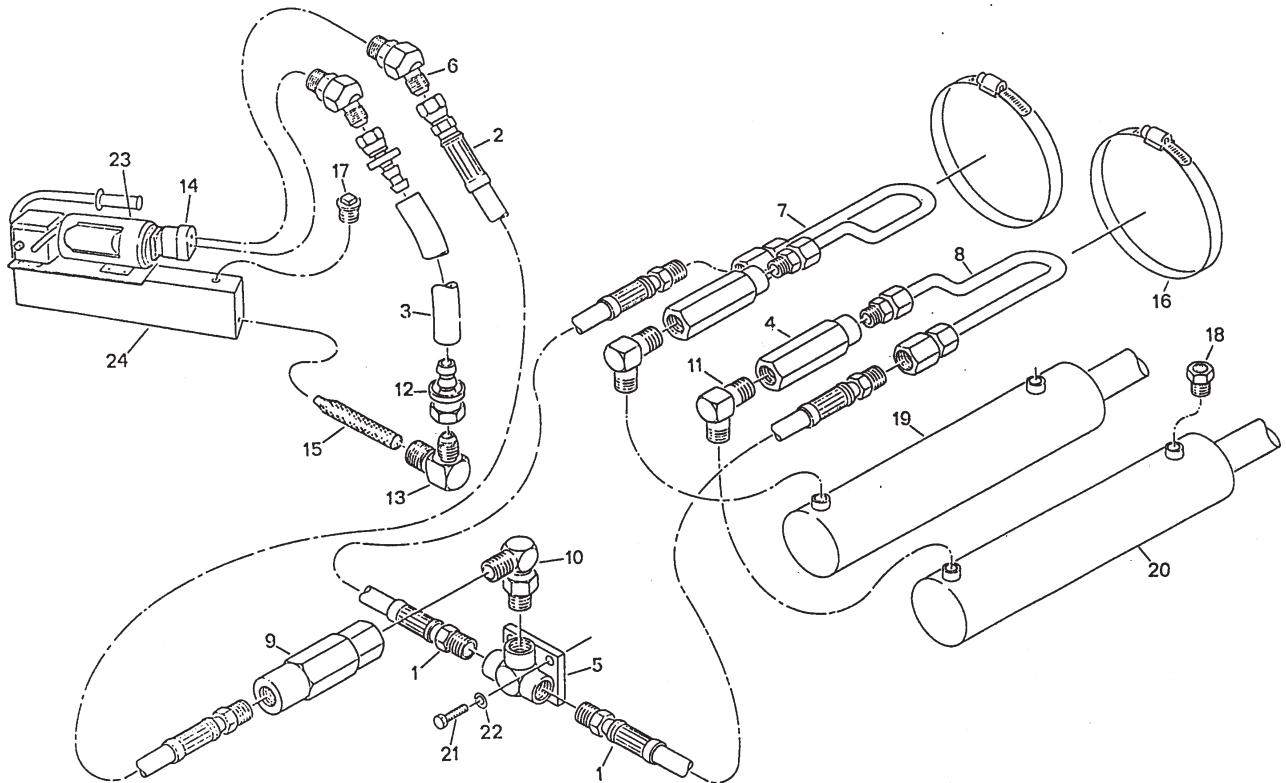
**Figure 10:**  
**Electrical Schematic**  
 208, 220, 440, 450 Volt,  
 3 Phase

Figure 11: XZT Hydraulic Schematic



DESCRIPTION OF PART	QTY	LIFT MODEL
Cylinder Seal Kit, 3-1/2" Cylinder	2	All
Down Solenoid, 115 Volts	1	All
Down Solenoid, 24 Volts AC	1	All
Pump Solenoid Stem	1	All
Hand Control	1	All
Foot Control	1	All
Toe Guard, 64"	1	TX, 50
Toe guard, 58"	1	TX, 44
Clevis Pull Pin	2	TZ

**Figure 12: Hydraulic Parts Layout – XZ & TZ**



**Figure 13: Replacement Parts XZT**

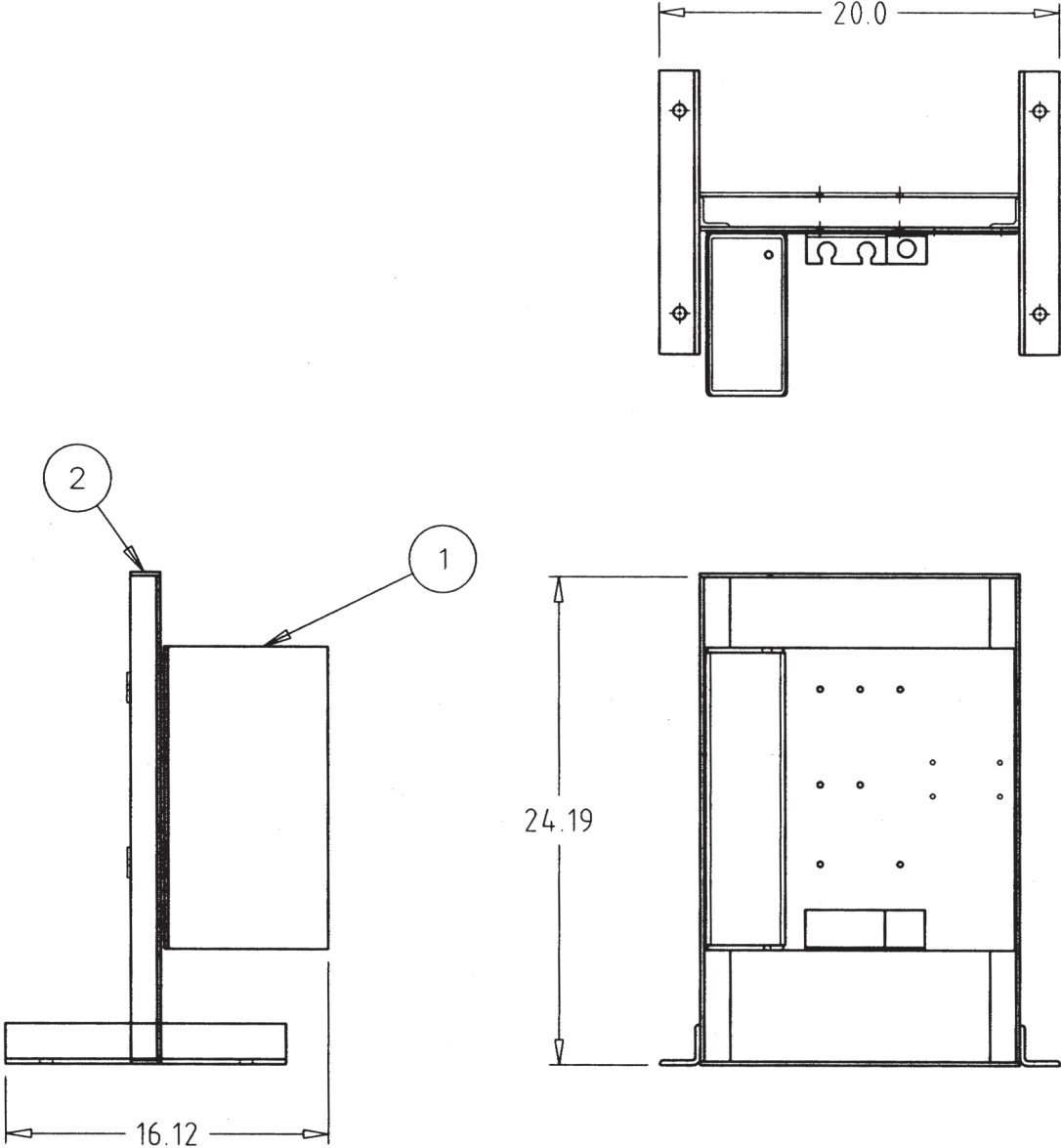
DESCRIPTION OF PART	QTY	LIFT MODEL
Hi Pressure Hose 38”	2	All
Hi Pressure Hose 96”	1	All
Lo Pressure Hose 8”	1	All
Hydraulic Safety Fuse	2	All
Tee Connector	1	All
Tee Assembly w/tapped holes	2	XZT
45 Elbow	1	All
Steel Tubing, left side	1	XZ
Steel Tubing, left side	1	TZ
Steel Tubing, right side	1	XZ
Steel Tubing, right side	1	TZ
Flow Control	4	All
Coupler, _ npt Female	2	XZT
Elbow, Swivel	1	All
Adapter	3	XZT
Elbow	2	All
Push on Fitting	2	All
Elbow	1	All
Pump 1 GPM	1	All
Pump 2 GPM	1	All
Filter	1	All
Hose Clamp	2	All
Reservoir Plug	1	All
Cylinder Vent	2	All
Cylinder	2	XZ
Cylinder	2	TZ
Motor, 1 Phase (Only Baldor)	1	All
Motor, 3 Phase (Only Baldor)	1	All
Reservoir	1	All

**Figure 13: Replacement Parts XZT continued**

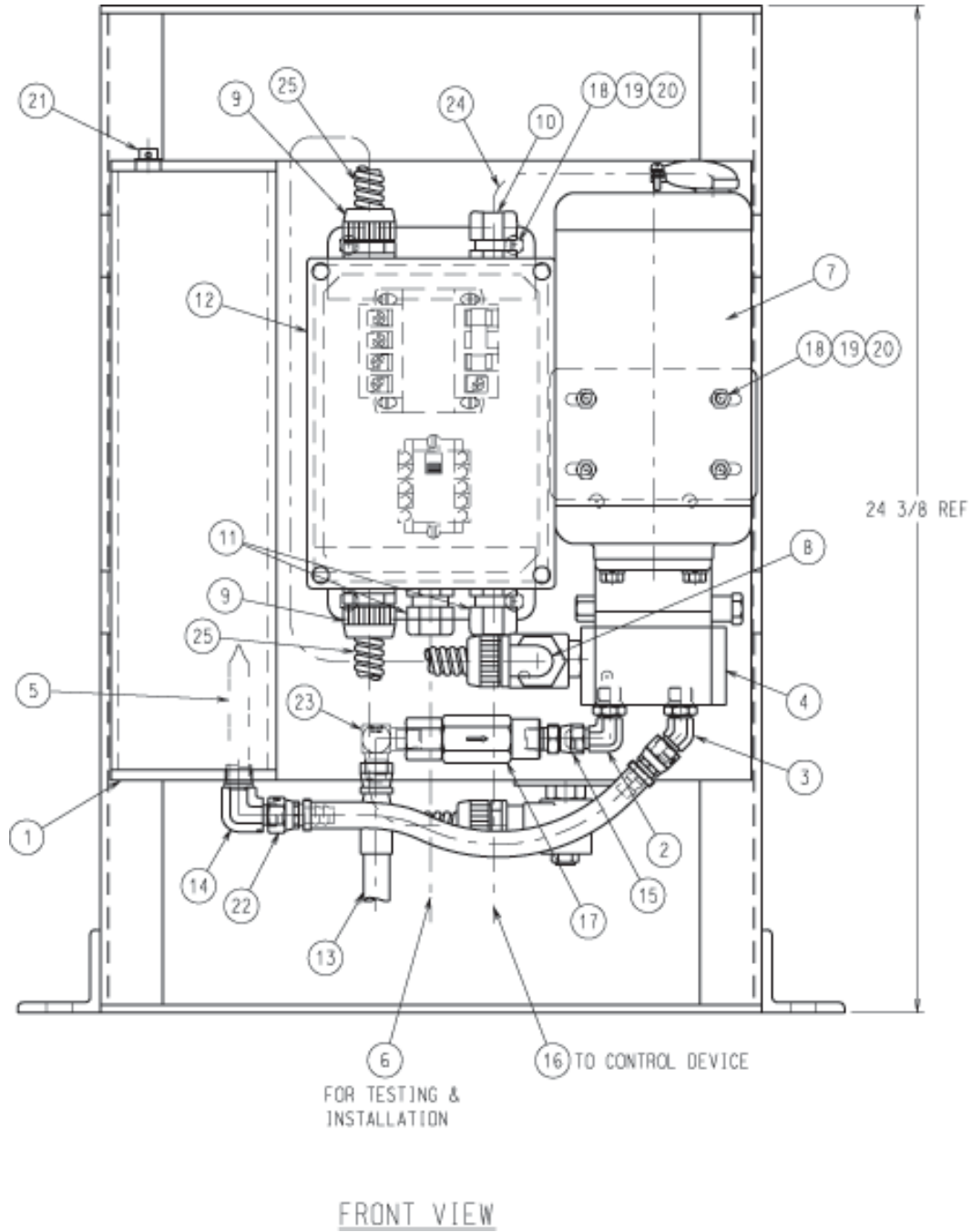
DESCRIPTION OF PART	QTY	LIFT MODEL
Cylinder Seal Kit, 3-1/2" Cylinder	2	All
Down Solenoid, 115 volts	1	All
Down Solenoid, 24 volts AC	1	All
Pump Solenoid Stem	1	All
Hand Control	1	All
Foot Control	1	All
Roller Assembly	4	All
Toe Guard, 64 _"	1	XZ & TZ, 50
Toe Guard, 58 _"	1	XZ & TZ, 44
Clevis Pull Pin	2	XZ & TZ
Safety Chock	2	XZ
Cylinder, Tilt LH	1	XZT
Cylinder, Tilt RH	1	XZT
Cylinder Packing Kit	2	XZT
Hi Press Hose 33"	2	XZT
Hydraulic Hose 3/8" 144" Lg	1	XZT
Hydraulic Hose 3/8" 35" Lg	1	XZT
Hydraulic Hose 180" Lg	1	XZT
Remote Stand	1	XZT
Control Stanchion w/out controls	1	XZT



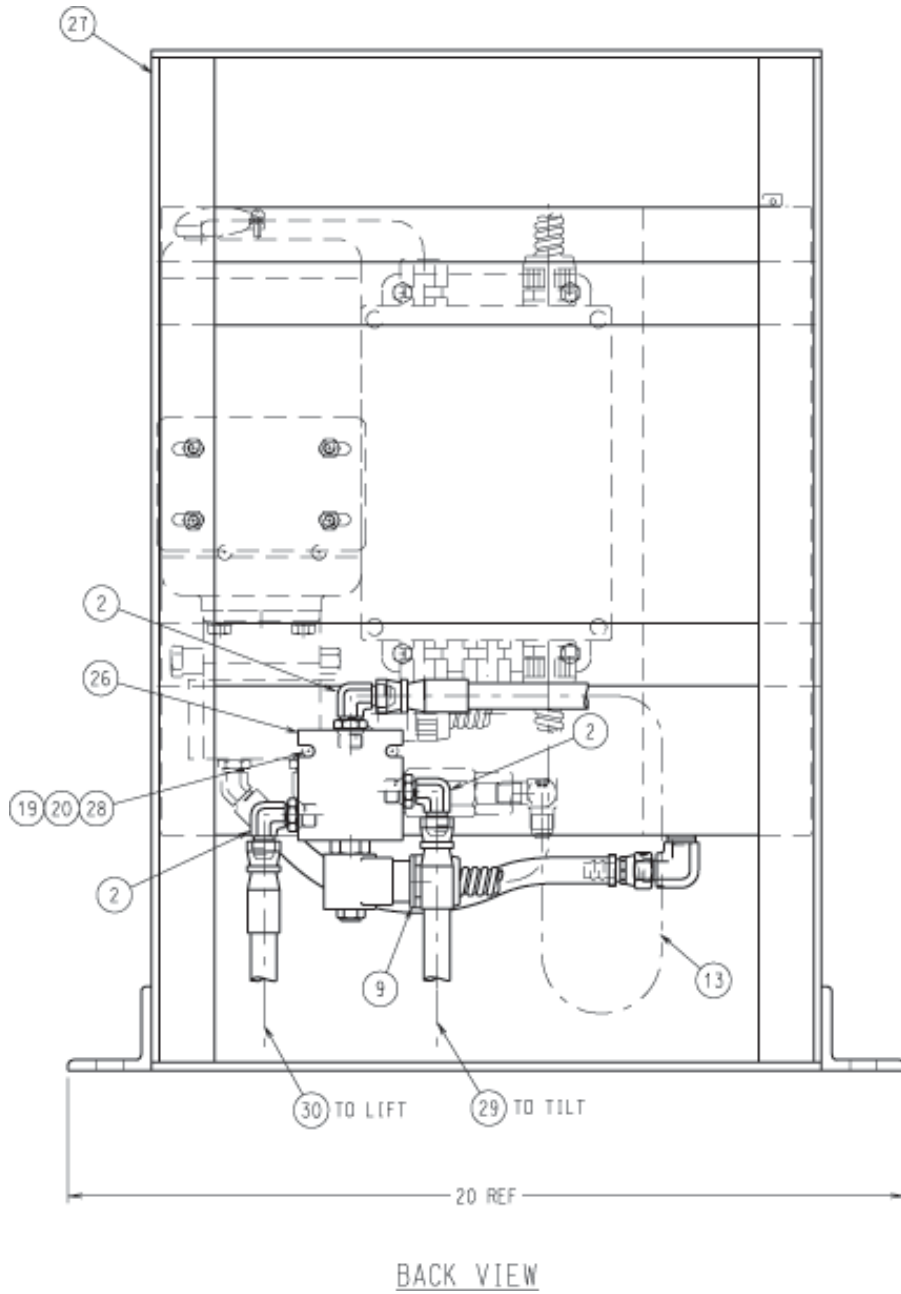
**Figure 14: XZT HPU Mounted on Stand**



**Figure 15a: XZT Hydraulic Parts Layout Front View**



**Figure 15b: XZT Hydraulic Parts Layout** Back View

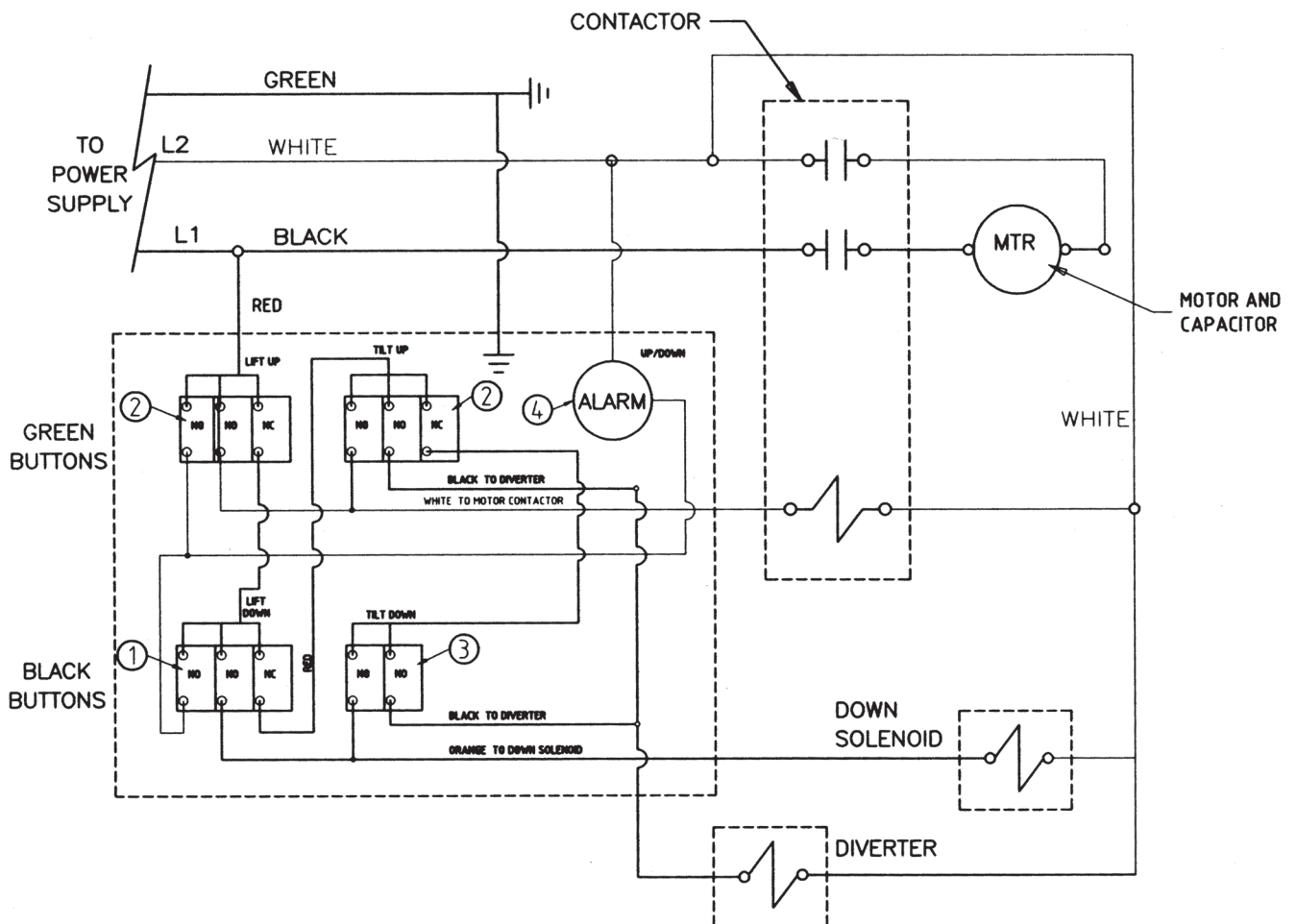


### XZT Hydraulic Parts List

1	Hy Tank Int	C	1
2	Hy Ftg Adptr	N	4
3	Hy Ftg Adptr	N	1
4	Hy Pump 1 GPM	C	1
5	Hy Screen	A	1
6	El Wire	N	2
7	El Mot 1.5HP 3P	C	1
8	Bk-El Ftg Conn		1
9	Bk-El Ftg Conn		3
10	El Ftg Strn Rlf	N	1
11	Bk-El Ftg Strn Rlf		2
12	El Ctrl Panel 230/460 115AC N12	B	1
13	Hy Hose Assy	A	1
14	Hy Ftg Adptr	A	1
15	Hy Ftg Adptr	N	1
16	El Cable		12
17	Hy Vlv Logic	B	1
18	Ha Screw HHCS Zincpl	N	8
19	Ha Nut Hex Zincpl	2	10
20	Ha Wshr Lck-Spt Zincpl	2	10
21	Ha Plug Vent Caplug	A	1
22	Hy Hose Assy	A	1
23	Hy Ftg Adptr		1
24	Hy Tube Neoprene	N	1
25	El Cnd Plytf	N	3
26	Hy Vlv		1
27	Sa Remote HPU Stand-XZT WM	C	2
28	Ha Screw HHCS STL	N	2
29	Hy Hose Assy	A	REF
30	Hy Hose Assy	A	REF
31	El Wiring Diag 208/230/460 AC XF MR	B	REF

**Figure 16: XZT with Up/Down Alarm Pedestal Control**

ITEM #	QTY	QTY	DESCRIPTION
1	1	1	BLK PB W/EXTRA CONTACTOR NO/NO/NC
2	2	2	GRN PB W/EXTRA CONTACTOR NO/NO/NC
3	1	--	BLK PB NO/NC
4	1	--	UP/DOWN ALARM BELL
5	12 FT	--	16/5 SJ0 BLK CONTROL CORD



**Table 1 – Hydraulic Oil Specifications**

If the lift will be used at normal ambient temperatures, Presto Lifts supplies the unit with Conoco Super Hydraulic 32 oil. This may be replaced by any other good quality oil with 150 SSU at 100° F and rust and oxidation inhibitors and anti-wear properties.

If the lift will be used at ambient temperatures below 0°F, use aircraft hydraulic oil. Use Type 15 aircraft hydraulic oil.

The following are equivalent to Conoco Super Hydraulic 32:

<b>TYPE</b>	<b>MANUFACTURER</b>
AW32 .....	CITGO
DTE 24 .....	EXXON/MOBIL
NUTO H32 .....	EXXON/MOBIL
AMOCO AW32 .....	CHEVRON (AMOCO CO.)



It is very important to keep the hydraulic oil free of dirt, dust, metal chips, water, and other contamination. Most of the problems with hydraulic systems are caused by contamination in the oil.

## Ordering Replacement Parts

Presto Lifts has carefully chosen the components in your unit to be the best available for the purpose. Replacement parts should be identical to the original equipment. Presto Lifts will not be responsible for equipment failures resulting from the use of incorrect replacement parts or from unauthorized modifications to the unit.

Presto Lifts can supply all replacement parts for your lift. With your order, please include the model number and the serial number of the unit. You can find these numbers on the name plate. This plate is located within the scissors mechanism.

To order replacement parts, please call the Presto Parts Department. Parts are shipped subject to the following terms:

- FOB factory
- Returns only with the approval of our parts department.
- Credit cards preferred (except parts covered by warranty).
- Freight collect for truck (except parts covered by warranty).
- Freight – prepaid and invoice for small parcel shipments (except parts covered by warranty).
- The warranty for repair parts is 30 days from date of shipment.

Parts replaced under warranty are on a “charge-credit” basis. We will invoice you when we ship the replacement part, then credit you when you return the worn or damaged part, and we verify that it is covered by our warranty. Labor is not covered under warranty for Parts orders.

### **Presto Parts Department**

50 Commerce Way  
Norton, MA 02766

Telephone: 800-343-9322

FAX: 888-788-6496

Email: [service@PrestoLifts.com](mailto:service@PrestoLifts.com)

**[www.PrestoLifts.com](http://www.PrestoLifts.com)**





## **PARTS**

Standard parts may be returned with a 20% restocking fee. Modified or custom-engineered parts are not returnable. Unfortunately, due to potentially concealed damage, all sales of electrical assemblies are final.

## **QUALITY ISSUES**

Should you feel there is a quality problem, please contact the seller to ask questions and gather information on how to rectify the issue. Presto Lift Inc. reserves the right to determine potential credits, as a result of factory defects, based on its inspection of the merchandise.

## **GENERAL**

All products shipped from our factory have passed Quality Assurance inspection and testing. The carrier of choice has signed for, and accepted the product in new working condition. The customer should inspect to ensure it is not received damaged, has no concealed damage or is not incomplete. Parts orders are determined to be complete based upon Presto Lift, Inc. inspection sheets and carrier shipping weights.

## **RETURN MATERIALS AUTHORIZATION POLICY**

Presto Lifts provides the Return Materials Authorization (RMA) Policy, for specific models, as a courtesy to our distributors in the event they do not receive what they ordered. If a customer wishes to return a Presto Lifts product, please contact the Customer Service Department and request an RMA number. This request must be made on or before the fifteenth calendar day following the date of Presto Lifts' invoice for the merchandise. Not all units are returnable. Quantity orders and special designs cannot be returned under any circumstances. Presto Customer Service reserves the right for final judgment on all product returns.

The RMA number must appear on the outside of any packaging material for a return to be accepted and processed by Presto Lifts. Customers shipping returns from the Continental US, Canada, or Mexico have thirty (30) days from date of RMA issue to have the product arrive at Presto Lifts' facility. All merchandise must arrive Free on Board at Presto Lifts' facility or the shipment will be refused and returned to the sender. All credits are issued less restocking and refurbishing charges, regardless if the merchandise was damaged in transit.

Return addresses: please refer to your RMA for the address to which your product should be returned.

Presto Lift Inc.  
715 Highway 77  
Manila, Arkansas 72442

Telephone: 800-343-9322  
Fax: 888-788-6496