

Presto LIFTS
worldwide material handling
and ergonomic solutions

SRT-20 and SRT-40 Container Tilters



Installation, Operation and Service Manual

Model Number _____

Serial # _____

Date Placed in Service _____

**IMPORTANT: READ CAREFULLY
BEFORE INSTALLING OR OPERATING LIFT**

Part orders are subject to a \$50 minimum charge.



Presto Lifts Limited Warranty Policy

Presto Lifts warrants all of its products against defects in the welded structural frame and, if applicable, scissor legs from faulty material and workmanship for a period of five (5) years from the date of invoice.

All other components have a limited warranty against defects in faulty material and workmanship for a two (2) year period from the date of invoice and 30 day limited warranty on labor. Please note that prior authorization from Presto Lifts is required on all warranty work.

There are no implied warranties of any kind, more specifically, there are no warranties of merchantability or fitness for any particular purpose. Presto Lifts' sole warranty shall be as set forth in this limited warranty.

Presto Lifts will elect to repair or replace a defective component without charge, if any components should become defective within the limited warranty period. Proof of purchase is required for warranty. The charge for shipping the defective component is the responsibility of the buyer and must be accompanied with an RMA number. The shipping charge to return the component to the buyer is the responsibility of Presto Lifts, Inc.

This limited warranty does not cover labor expense for removal or reinstallation of components after thirty days. This limited warranty shall not cover, among other things: damages resulting from foreign matter or water, failure to provide reasonable and necessary maintenance, and if applicable, use of product while charger is plugged into an AC outlet, or failure to follow operating instructions. The limited warranty is not valid for damage resulting from negligence, accident, unreasonable use, abuse or misuse, exceeding data plate capacities or altering the product without Presto Lifts authorization.

Presto Lifts expressly disclaims and excludes any liability for consequential, incidental, indirect or punitive damages or financial loss to people or property resulting from any breach of warranty or the operation or failure of this product.

Presto Lifts makes no representation that this product complies with local, state, or federal safety/product standards codes. Should this product fail to comply in any way with those codes, it shall not be considered a defect of materials or workmanship. Presto Lifts shall not be held liable for any damages resulting from noncompliance. It is the dealer's responsibility to exercise this limited warranty. This limited warranty is provided to the original purchaser (defined as the original end user) and is nontransferable. This constitutes the complete and final agreement involving Presto Lifts and limited warranty obligations for products.

Introduction

The Presto SRT Container Tilters are designed to position parts containers at a convenient working height. This allows workers to reach the parts without bending or stretching. Unit features floor-height roll-on designs. This allows containers to be placed directly on the tilter in a single step, using a fork truck or hand pallet truck. The SRT models have two separate lifting arms and are designed to lift loads which are delivered by a pallet jack. Two models are available for maximum load capacities of 2,000 lbs and 4,000 lbs. Using a pushbutton control the operator can position the load at any angle between 0° and 89°.

This manual contains instructions on the safe and proper installation, use, and maintenance of a SRT tilter. Be sure that this manual is available to the people who install, use, or service the unit. Be sure that all personnel read this manual before they install, use or service the unit.

These units may be used in a wide variety of industrial settings. The instructions in this manual are not necessarily all-inclusive, as Presto cannot anticipate all conceivable or unique situations. In the interest of safety, please read this whole manual carefully. Please understand the material in this manual before you install, use, or service the unit. If you have any questions about any of the instructions in this manual, please contact Presto Lifts.

Presto's product warranty is shown on the rear cover of this manual. This instruction manual is not intended to be or to create any other warranty, express or implied, including any implied warranty of merchantability or fitness for a particular purpose, all of which are hereby expressly excluded. As set forth more specifically in the product warranty, Presto's obligation under that warranty is limited to the repair or replacement of defective components, which shall be the buyer's sole remedy, and Presto shall not be liable for any loss, injury, or damage to persons or property, nor for any direct, indirect, or consequential damage of any kind resulting from the SRT Container Tilter.

Contents

WARRANTY	2
INTRODUCTION	3
RESPONSIBILITY OF OWNERS AND USERS	5
SAFETY	6-7
INSTALLATION INSTRUCTIONS	8
Preparation	8
Positioning the Unit.....	8
Electrical Connections	8
Testing	9
OPERATING INSTRUCTIONS	11
Loading the Unit	11
Raising the Tilt Platform	12
Moving the Unit	12
MAINTENANCE & TROUBLESHOOTING.....	13
Hazards	13
Routine Periodic Maintenance	13
Changing the Hydraulic Fluid	13
Troubleshooting Check List.....	16
REPACKING THE CYLINDER	14
ORDERING REPLACEMENT PARTS	19
RETURN MATERIALS AUTHORIZATION	22

List of Figures

Fig. 1	Installing the Unit	8
Fig. 2	Pinch Points.....	9
Fig. 3	Safety Markings	10
Fig. 4	Push the Load Back.....	10
Fig. 5	Correct Load Center Ranges.....	11
Fig. 6	Center the Load	11
Fig. 7	Don't Overfill the Container.....	12
Fig. 8	Hydraulic Pump.....	15
Fig. 9	Down Valve	15
Fig. 10	Electrical Diagram.....	17
Fig. 11	Hydraulic Diagram	18
Fig. 12	Parts Identification - Side View (SRT-20, SRT-40)	19
Table 1	Hydraulic Oil Specifications	20
Fig. 13	Labels and Locations.....	21

Responsibility of Owners and Users

Inspection and Maintenance

The device shall be inspected and maintained in proper working order in accordance with Presto's owner's manual.

Removal from Service

Any device not in safe operating condition such as, but not limited to, excessive leakage, missing rollers, pins, or fasteners, any bent or cracked structural members, cut or frayed electric, hydraulic, or pneumatic lines, damaged or malfunctioning controls or safety devices, etc. shall be removed from service until it is repaired to the original manufacturer's standards.

Repairs

All repairs shall be made by qualified personnel in conformance with Presto's instructions.

Operators

Only trained personnel and authorized personnel shall be permitted to operate PowerStak.

Before Operation

Before using the device, the operator shall have:

- Read and/or had explained, and understood, the manufacturer's operating instructions and safety rules.
- Inspected the device for proper operation and condition. Any suspect item shall be carefully examined and a determination made by a qualified person as to whether it constitutes a hazard. All items not in conformance with Presto's specification shall be corrected before further use of the PowerStak.

During Operation

The device shall only be used in accordance with this owner's manual.

- Do not overload.
- Ensure that all safety devices are operational and in place.

Modifications or Alterations

Modifications or alterations to any Presto industrial positioning equipment shall be made only with written permission from Presto.

Safety

The safety of all persons installing, using, servicing, or working near the SRT unit is of paramount concern to Presto. The SRT unit is a powerful machine with moving parts, and is **capable of causing personal injury if proper precautions are not taken**.

Therefore, throughout this manual, Presto has identified certain hazards which may occur in the use of the SRT unit, and provided appropriate **instructions** or **precautions** which should be taken to avoid these hazards. In some cases, Presto has also pointed out the **consequences** which may occur if Presto's instructions or precautions are not followed. Presto uses the following system of identifying the severity of the hazards associated with its products:

DANGER – Immediate hazard which will result in severe personal injury or death.

WARNING – Hazard or unsafe practice that could result in severe personal injury or death.

CAUTION – Hazard or unsafe practice that could result in minor personal injury or property damage.

Please read and follow this instruction manual, including all safety instructions and precautions, carefully and completely.

SAFETY ALERT SYMBOLS AND SIGNAL WORDS

The safety of all persons operating, maintaining, repairing, or in the vicinity of this equipment is of paramount concern. This is a powerful machine with moving parts, and is capable of causing personal injury if proper precautions are not taken. Therefore, throughout this manual, certain hazards have been identified which may occur in the use of the machine, and there are appropriate instructions or precautions which should be taken to avoid these hazards. In some cases, there are consequences which may occur if instructions or precautions are not followed. Below are the symbols and signal words along with their definitions referenced from ANSI Z535.4 - Product Safety Signs and Labels.

Safety Alert Symbols

These are the safety alert symbols.. They are used to alert you to potential physical injury hazards. Obey all safety messages that follow this symbol to avoid possible injury or death.



For use with DANGER signal word
(Red Background)



For use with WARNING signal word
(Orange Background)



For use with CAUTION signal word
(Yellow Background)

Signal Words

The meaning of different signal words as defined by ANSI Standard Z535.4 indicates the relative seriousness of the hazardous situation.



(Red Background)

DANGER indicates a hazardous situation which, if not avoided, will result in death or serious injury.



(Orange Background)

WARNING indicates a hazardous situation which, if not avoided, could result in death or serious injury.



(Yellow Background)

CAUTION, used with the safety alert symbol, indicates a hazardous situation which, if not avoided, could result in minor or moderate injury.



(Blue Background)

NOTICE is used to address practices not related to personal injury.



(Green Background)

SAFETY INSTRUCTIONS (or equivalent) signs indicate safety-related instructions or procedures.

Installation Instructions

Preparation

1. Before you start to use the unit, check for local codes and ordinances which may apply. It is your responsibility to obtain any necessary permits.
2. Read all of these installation instructions carefully. Be sure to read and understand all of the warnings.
3. The unit should only be used indoors, or it should be protected from the weather.

WARNING

- Protect the unit from rain or moisture. If the electrical parts in the power unit get wet, workers may be hurt by electrical shock. The electrical parts may fail if they are wet.

CAUTION

- This unit has an electric motor that can create sparks. Don't use the unit in an area where flammable gases may be present.

4. You will need these tools to install the unit:
 - A crane or lift truck that can lift the unit safely.
 - Shims and lag bolts.
 - A masonry drill and bit to drill the holes for the lag bolts.
 - Wrenches to fit the lag bolts.

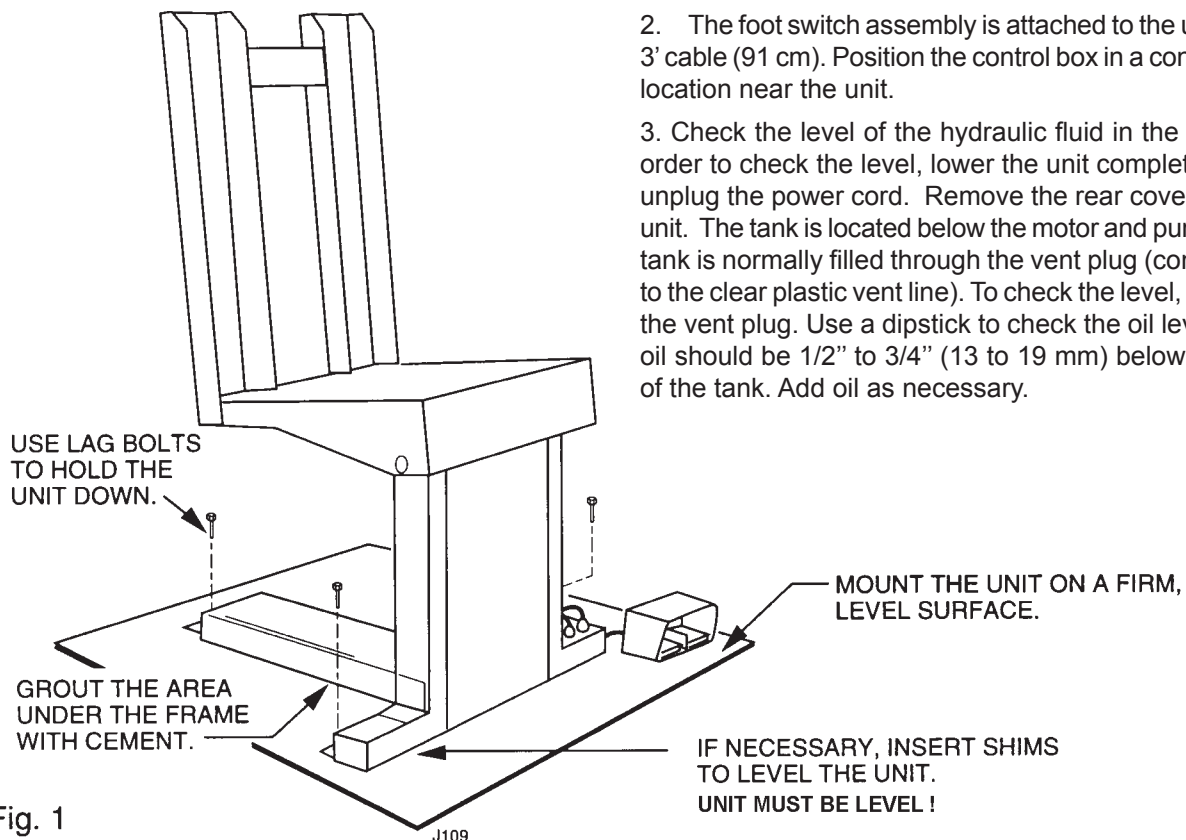

Fig. 1
Installing the unit

POSITIONING THE UNIT

1. Remove the shipping material and unskid the unit. You will need a crane or lift truck that can lift the unit safely.

CAUTION

Do not try to move the lift by supporting the tilt platform. One end of the tilt platform is free.

WARNING

If the unit is mounted on an unstable surface, it may tip over when it is in use. You may be hurt, and the unit and load may be damaged.

ELECTRICAL CONNECTIONS

1. The unit has a power cord which is 10' long (305 cm). At each location where you want to use the unit, be sure a three-prong outlet is available. Each circuit should have a 20 amp dedicated circuit breaker or fuse.

DANGER

The unit uses a power supply of 115 volts AC. This voltage can kill you. Don't work with the electrical parts unless you are a qualified electrician.

WARNING

To avoid fire danger, be sure to provide a circuit breaker or fuse.

2. The foot switch assembly is attached to the unit by a 3' cable (91 cm). Position the control box in a convenient location near the unit.
3. Check the level of the hydraulic fluid in the tank. In order to check the level, lower the unit completely and unplug the power cord. Remove the rear cover on the unit. The tank is located below the motor and pump. The tank is normally filled through the vent plug (connected to the clear plastic vent line). To check the level, remove the vent plug. Use a dipstick to check the oil level. The oil should be 1/2" to 3/4" (13 to 19 mm) below the top of the tank. Add oil as necessary.

Testing

1. Clear the area around the unit, and warn others to stay away from the unit. Remove any loose wires, lumber, or other materials which might get in the way of the unit as it raises or lowers.

2. Operate the unit through its full range of travel. The unit should rise smoothly with a quiet humming sound, and lower smoothly and quietly. Raise and lower the unit a few times to check the clearances around the tilt platform.

⚠️WARNING

As the tilt platform moves up and down, “pinch points” are created at the places shown in Fig. 2. If you are standing too close to the unit when it is moving, your arm or leg may be caught in the moving parts, and you may be hurt. Stay away from the pinch points when the unit is moving.

3. If the unit is lowering too quickly or too slowly, you can change the “down speed” by adjusting the flow control.

If you want the tilt platform to lower more slowly, turn the control clockwise up to 1/4 turn at a time. If you want the tilt platform to lower more quickly, turn the control counterclockwise up to 1/4 turn. Don't move the control more than 1/4 turn at a time.

4. Test the unit with the rated load. If the unit does not rise, and you hear a loud squealing noise, the pressure relief valve is operating. Contact Presto for instructions.

⚠️WARNING

Don't continue to use the unit if this happens – the pump will overheat very quickly, and may be permanently damaged. Do not try to adjust the relief valve. If you change the setting on the relief valve, you may overwork the unit. This can cause the unit to fail suddenly, and you may be hurt.

5. Clean up any spilled hydraulic fluid. Spilled hydraulic oil is slippery, and may present a fire hazard. If you clean up any spilled fluid, you will be able to tell right away if the unit begins to leak.

5. Figure 3 shows the safety labels on this unit. Check to be sure all of the labels are in place.

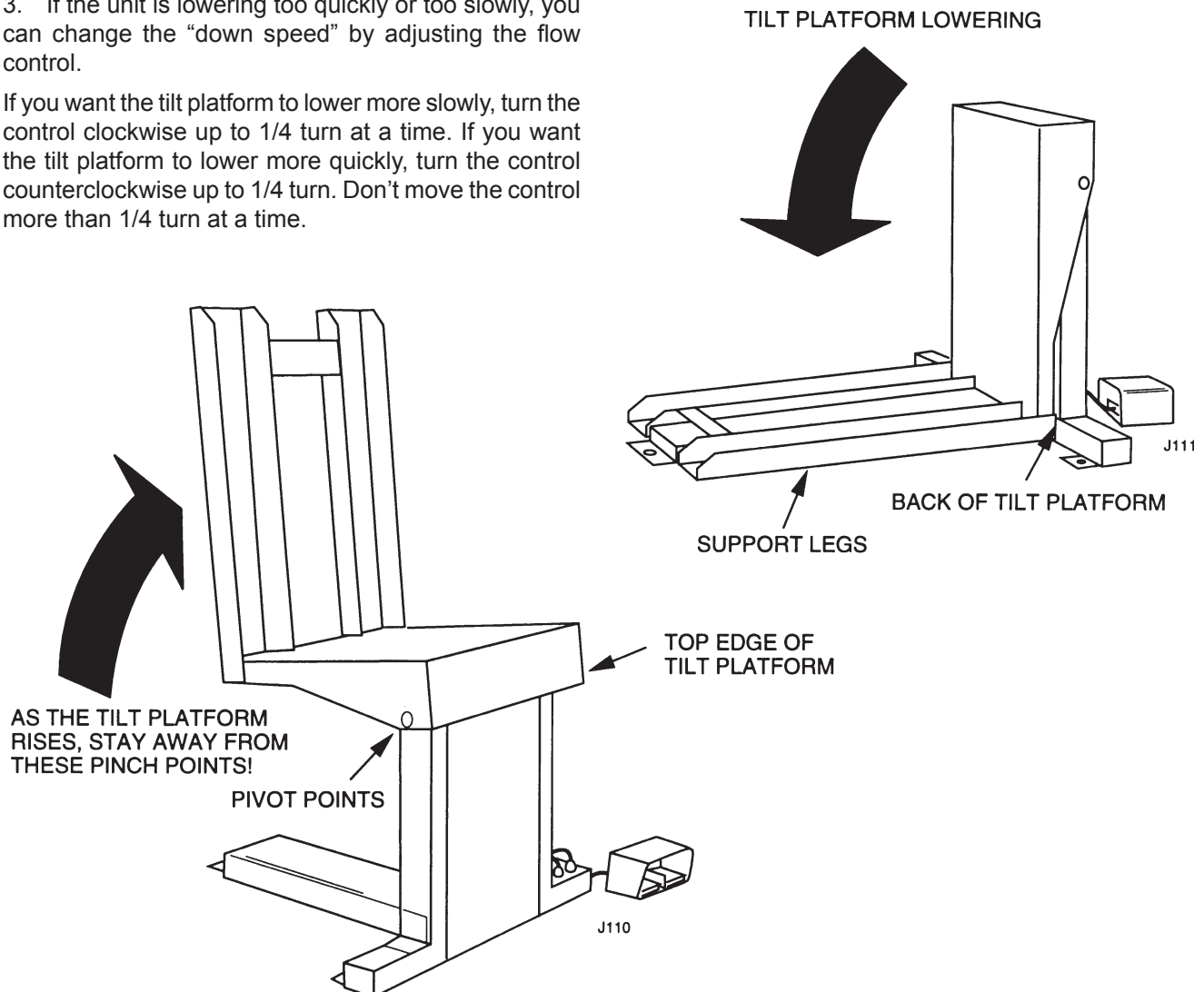

Fig. 2. Pinch Points

A statement of voltage:

**115 VOLTS
1 PHASE**

A warning to keep away from the moving parts of the lift:

**CAUTION
DO NOT PUT HANDS UNDER TABLE
DO NOT PUT FEET UNDER TABLE
DO NOT STAND OR SIT ON TABLE**

A statement of rated capacity
(example shown here):

**CAPACITY
2000 LBS.**

A note regarding the level of the hydraulic fluid:

**TANK TO BE FULL ONLY WHEN
CYLINDER IS COLLAPSED**

The tilt platform is painted safety orange.

(Note: These are samples of typical warning labels. The labels on your machine may be slightly different.)

Fig. 3. Safety Markings

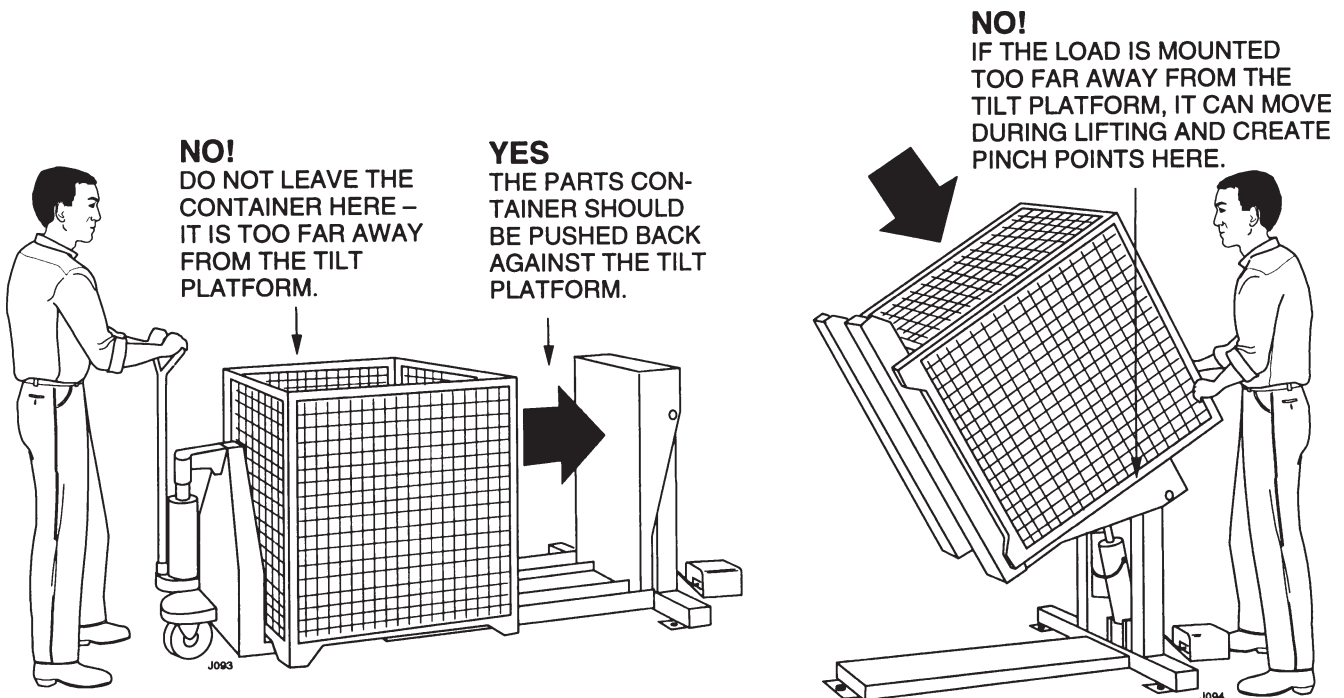

Fig. 4. Push the Load Back

Operating Instructions

Loading the unit

1. Before operating the unit, please read and understand this entire section.

⚠ DANGER

This unit uses a power supply of 115 Volts AC. This voltage can kill you. Don't work with the electrical parts unless you are a qualified electrician!

2. Load the unit correctly.

Before lifting, be sure the lifting container is pushed against the tilting platform, as shown in Fig. 4. If you do not do this, the container may slide down and create dangerous "pinch points."

Be sure that the load weighs no more than the maximum rated for the unit. The maximum rated load is listed on the tilt platform. Remember that the lifting container may weigh 75 lbs. or more. Push the load back against the tilt platform.

⚠ WARNING

The tilt platform should always be pushed against the load. If the load is placed far out on the lifting arms, the unit may not be able to lift the full rated load safely. See Fig. 5.

SRT Models - Load center may be up to 20" from the tilt platform

SRT-20 Max. load 2,000 lb.

SRT-40 Max. load 4,000 lb.

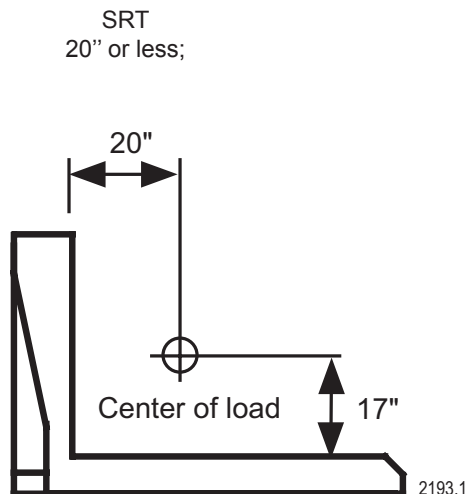

Fig. 5. Correct Load Center Ranges

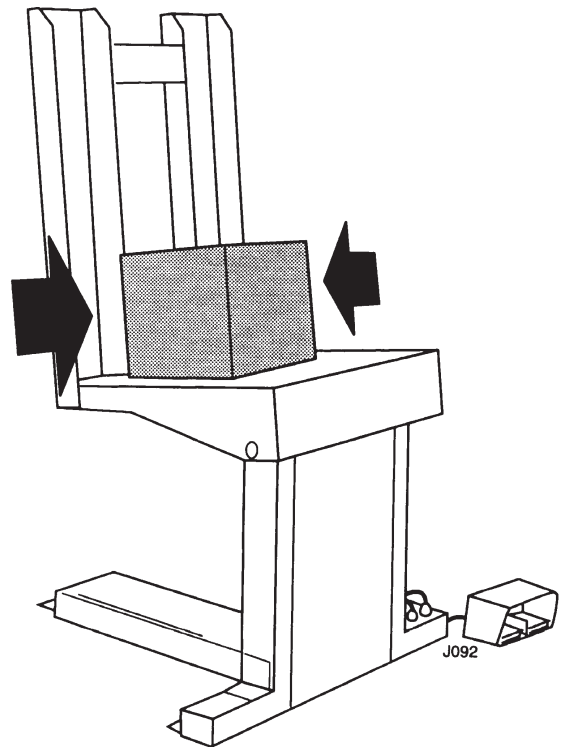

Fig. 6. Center the Load

⚠ WARNING

Don't try to lift a load that exceeds the maximum rating. Only lift a load if the center of load is within the allowable range. If you do not follow these rules, the unit may fail suddenly. Someone may be hurt, and the unit and load may be damaged.

3. The load should be balanced in the side-to-side direction. Whenever possible, place the load in the center of the tilting platform, as shown in Fig. 6. If the load is off-center on the pallet, place the heaviest part of the load near the back of the tilt platform – never near the front!

4. Sometimes the unit may be used to lift parts which can roll. If possible, stack the parts in the parts container so they cannot roll. Do not overfill the lifting container. See Fig. 7. If the container is too full, some of the parts may roll out of the front of the container.

⚠ WARNING

Don't overfill the lifting container. As the unit lifts, some of the parts may roll out of the front of the container. The falling parts may hurt you or damage the unit.

Raising the Tilt Platform

1. Before raising the tilt platform, be sure all workers are clear of the unit.

⚠️ WARNING

As the tilt platform moves up and down, “pinch points” are created as shown in Fig. 2. Stay away from these pinch points! Part of your body or clothing may become caught, and you may be hurt. Do not put your hands or feet under the tilt platform. Do not stand or sit on the tilt platform.

2. Before lifting, be sure the parts container is pushed up against the tilt platform, as shown in Fig. 4. Be sure the load is balanced side-to-side, as shown in Fig. 6.
3. Plug in the AC cord. Be sure the cord cannot become caught in the moving parts as the platform raises.

⚠️ WARNING

Be sure that the electrical power cord will not be pinched by the unit as it raises or lowers. If you allow the cord to be pinched, it may be broken. This can create a shock hazard. To avoid this problem, always check the position of the cord before you start to raise or lower the unit.

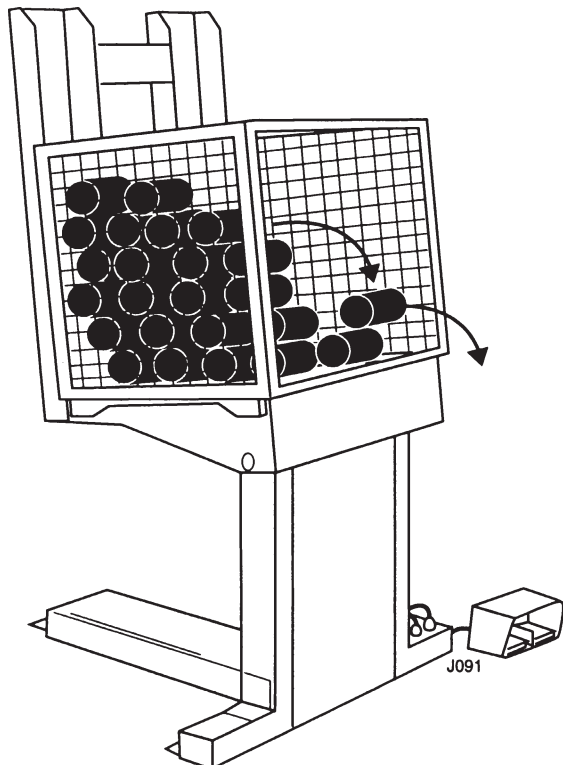

Fig. 7. Don't Overfill the Container

5. Operate the unit. Press and hold the Up button to raise the tilt platform, and Down to lower it. If the unit does not operate right away, unplug the power cord and call a qualified maintenance worker.

⚠️ WARNING

This power unit contains a hydraulic pump that is capable of developing excessive pressure. A pressure relief valve is used to set the pressure at a desired level. Tampering with, adjusting, modifying or removing the relief valve is extremely dangerous and is not recommended. Only a trained hydraulics technician, using a calibrated hydraulic pressure gauge to assure the proper pressure setting is achieved, should make adjustments to the relief valve.

Moving the Unit

1. Before moving the unit, always lower the tilt platform. You should do this even if the unit is not loaded.

⚠️ WARNING

If you try to move the unit while the tilt platform is raised, the unit may be unstable. You may be hurt, and the lift or load may be damaged.

2. Unplug the power cord. Place the end over the top of the unit, so the cord does not drag.

⚠️ CAUTION

As you move the unit, do not allow the power cord to drag on the floor. The cord may catch on something and stop the unit suddenly.

3. Before moving, release the floor lock.
4. Always roll the unit across a stable, solid surface.

⚠️ WARNING

If the floor is not stable or solid, the unit may tilt over. You may be hurt, and the unit or load may be damaged.

Maintenance and Troubleshooting

All servicing should be done by qualified personnel. Qualified personnel should be able to read and understand wiring and hydraulic diagrams. They should be able to troubleshoot live electrical circuits safely and in accordance with accepted practice. **For safety's sake**, if in doubt, please contact your dealer or Presto Lifts Customer Service Department at (800) 343-9322.

Before servicing the unit, please read and understand all of this section and the section entitled "Operating Instructions."

Hazards

There are several hazards you should be aware of as you service the unit:

⚠ DANGER

- **The unit uses a power supply of 115 Volts AC. This voltage can kill you. Do not work on the electrical parts unless you are a qualified electrician!**

⚠ WARNING

- **As the unit moves up and down, "pinch points" are formed as shown in Fig. 2. Keep hands, feet, and loose clothing away from these pinch points. If your hand or arm or a part of your clothing is caught, you may be hurt.**
- **Before performing any maintenance on the unit, lower the tilt platform completely. Failure to do so could result in severe personal injury.**
- **The relief valve has been included for the protection of all of the workers who use the unit. Don't change the relief setting! If the relief valve does not open when it should, the unit may fail. Someone may be hurt, and the unit and load may be damaged.**
- **If the hydraulic fluid is released under high pressure, it can cause personal injury. Before you open any part of the hydraulic system, be sure to release the hydraulic pressure. You can do this by lowering the tilt platform all the way down.**

- **The warning labels have been included for the safety of the operator. If the labels are worn or missing, or have been painted over, replace them before releasing the lift for operation. Fig. 3 shows the safety markings on this unit.**

Routine Periodic Maintenance

Every month:

Visually inspect the pins and bushings at each end of the cylinder(s) for signs of wear. Also check the pivot pins at both sides of the tilt platform. If any of these parts are worn, contact Presto for repair instructions.

- Apply oil or WD-40 to the parts listed in the last step.

Note: Although the bushings are "lifetime lubricated" Teflon® bushings, their performance may be extended by additional periodic lubrication.

- Check the level and appearance of the hydraulic fluid. In order to check the level, lower the unit completely and unplug the power cord. Remove the rear cover on the unit. Lower the platform. Remove the red plastic vent plug on top of the hydraulic tank, and use a dipstick to check the oil level. When the platform is fully lowered, the oil should be about 1/2 to 3/4 inches below the top of the tank. Add oil if necessary. Change the oil if it has darkened, or feels gritty or sticky.

⚠ CAUTION

It is important to use hydraulic fluid with the correct grade and properties. See the hydraulic oil specification in Fig. 17 of this manual.

Every six months or 500 hours of operation, whichever comes first:

- Check all of the hydraulic fittings and hoses, and tighten the connections if necessary. Sometimes the fittings can be worked loose by the vibrations from the power unit.

⚠ WARNING

If a hydraulic fitting becomes loose, or if a hydraulic hose breaks, the hydraulic fluid may escape from the system under pressure. If the tilt platform is raised when this happens, it can drop quickly. Someone may be hurt, or the unit or load may be damaged. To avoid this problem, inspect all of the hydraulic hoses and fittings regularly, and replace them if they are worn or damaged.

- The clear plastic vent line(s) and the cylinder rod(s) should be free of hydraulic fluid. If you find much fluid in either place, the cylinder seals may be leaking. (It is also possible the tank may be overfilled.) If the worn parts must be replaced, see the section on “Repacking the Cylinder(s).”
- Disassemble the down valve as shown in Fig. 9. Blow the valve plunger clean with compressed air. Reassemble the valve and reinstall it.
- Drain and discard the hydraulic fluid. The suction filter is in the tank, at the point where the suction line runs out to the pump. Unscrew the hydraulic line, then remove the filter. Blow the filter clean with compressed air. Reinstall the filter in the tank and reassemble the hydraulic line.
- Refill the tank with new hydraulic fluid.



If you continue to use fluid after it has “worn out,” the moving parts in the system will wear more quickly.

- Be sure all of the warning labels are in position and legible. **The warning labels are intended to protect your workers.** If the labels are missing, or if they have been painted over, replace them.

Repacking the Cylinder

The lift in the SRT unit may use several different types of cylinders. To order a repacking kit and to receive instructions, please call the Presto Parts Department at (800) 343-9322. When ordering, specify the model number and serial number of the unit.

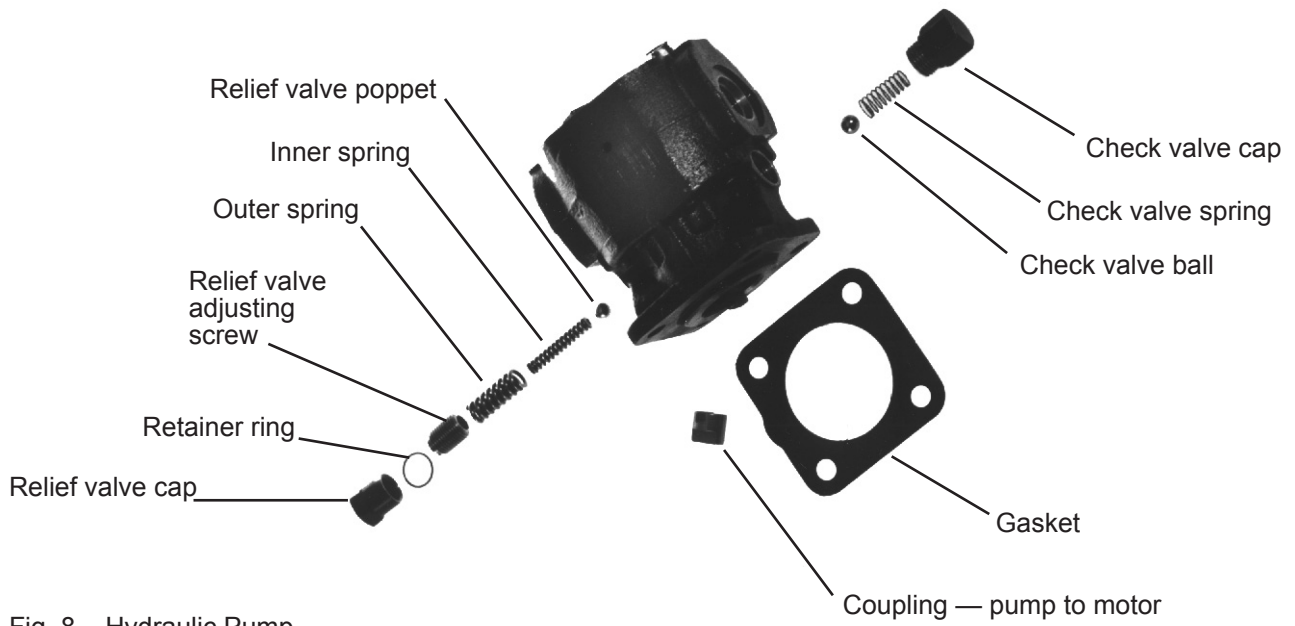

Fig. 8 Hydraulic Pump

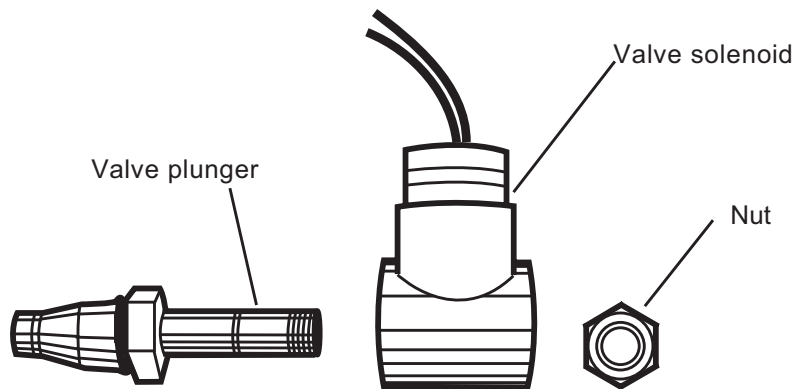

Fig. 9 Down Valve

Problem	Possible Cause	Check This
Tilt Platform will not raise	Battery may need charging	Battery volt level
		Is the charger putting out 12 volts?
		Check that 12 volts is being reached at the motor & motor relay
		Is the charger operating properly?
	Load is too heavy	Verify the load weight
	Unit is low on oil	Inside the tank, make sure the oil is full to the elbow in the filler pipe.
	Tank vent may be plugged.	Look to see that the solid plug is not in place of the vent plug.
Unit elevates but will not hold a load	Down valve coil may be energized.	Remove the down valve and ensure it is not being energized when the up button is pushed. Check wiring to the down valve.
		Ensure debris is not holding the down valve plunger open.
	Cylinder may be leaking	Check the vent line for signs of oil
Unit fails to lower	Down valve coil may not be energized	Make sure the coil is energized when the down button is pushed.
		Ensure the down valve itself is shifting and allowing oil to go back to the tank (do not remove this under pressure)
		Check that nothing is binding causing the unit not to lower.

If the steps listed above do not solve the problem, please call the Presto Lifts. Customer Service Department at 800-343-9322.

Troubleshooting

All servicing should be done by qualified personnel. Qualified personnel should be able to read and understand wiring and hydraulic diagrams. They should be able to troubleshoot live electrical circuits safely and in accordance with accepted practice. **For safety's sake**, if in doubt, please contact Presto Lifts at (800) 343-9322.

Before servicing the unit, read and understand this entire section and the section entitled "Operating Instructions."



Before performing any maintenance on this unit, lower the tilt platform completely.



If the platform will not raise, do not continue to hold the Up button for more than 2 or 3 seconds. You may damage the pump.



Don't change the setting of the relief valve. If you do change the setting, this may cause a hydraulic part to fail. The tilt platform may drop suddenly. Someone may be hurt, and the unit and load may be damaged. The hydraulic parts in the lift are designed to handle a certain amount of pressure. The relief valve is set to relieve this pressure before it becomes too great. The relief valve has been included for the protection of all of the workers who use the unit.

Fig. 10 Electrical Diagram

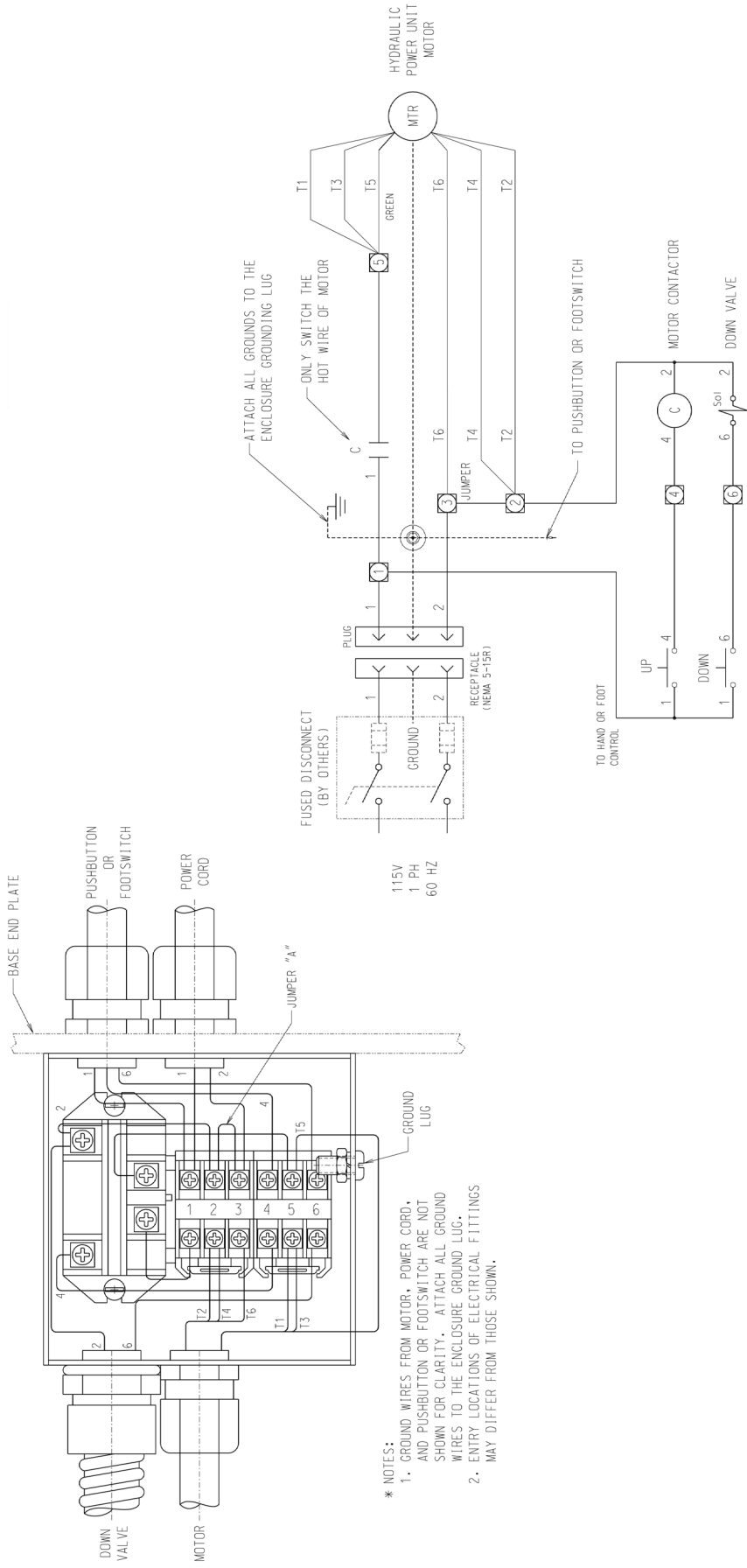
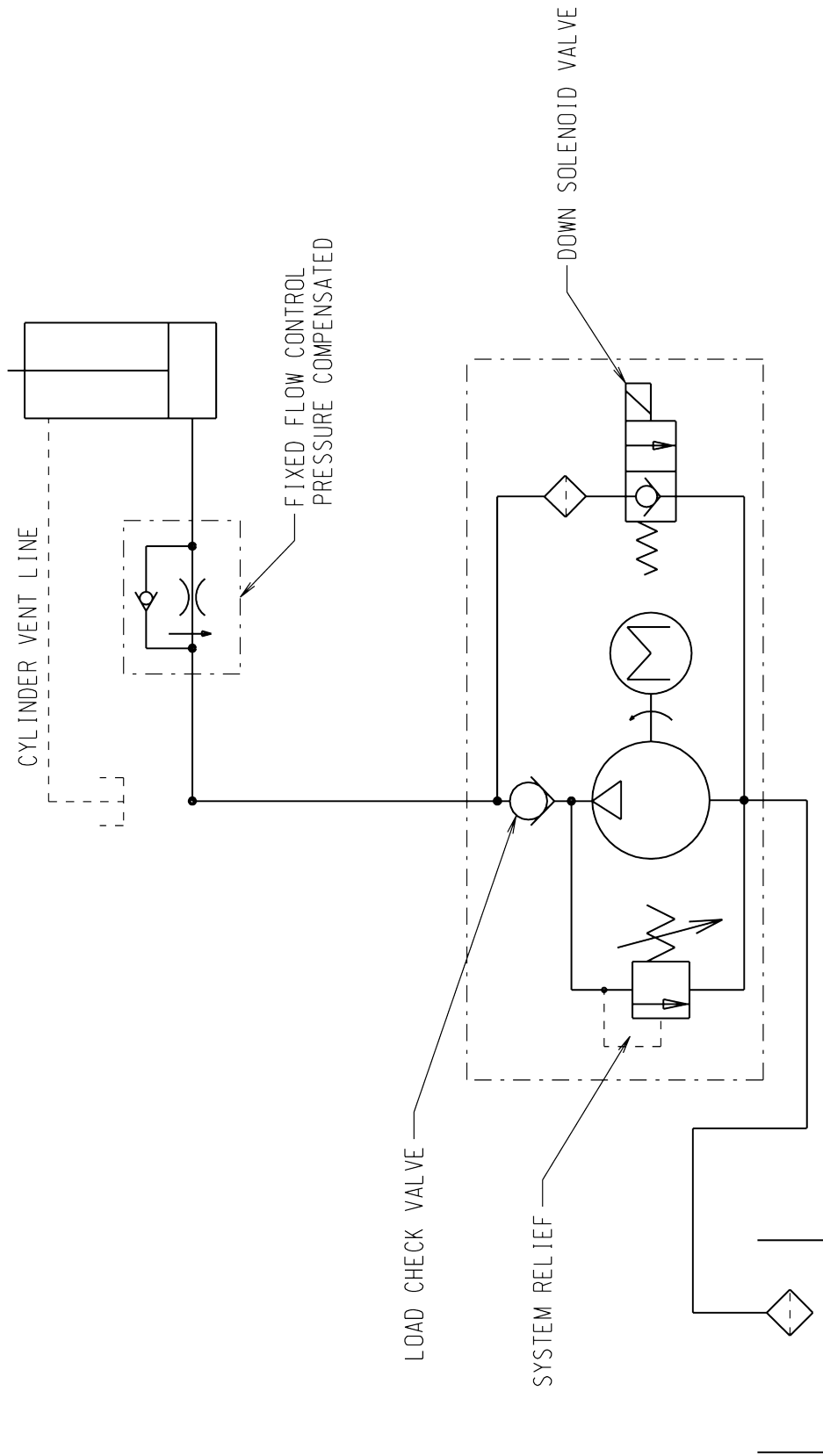

Fig. 11 Hydraulic Diagram



Ordering Replacement Parts

Presto has carefully chosen the components in your unit to be the best available for the purpose. Replacement parts should be identical to the original equipment. Presto will not be responsible for equipment failures resulting from the use of incorrect replacement parts or from unauthorized modifications to the machine.

Presto can supply all replacement parts for your Presto lift. With your order, please include the model number and the serial number of the unit. You will find these numbers on the nameplate.

To order replacement parts, please call the Parts Department at (800) 343-9322. Parts are shipped subject to the following terms:

- FOB factory.
- Returns only with the approval of our parts department.
- Payment net 30 days (except parts covered by warranty).

- Freight collect (except parts covered by warranty).
- The warranty for repair parts is 30 days from date of shipment.

Parts replaced under warranty are on a “charge-credit” basis. We will invoice you when we ship the replacement part, then credit you when you return the assumed substandard part, and we verify that it is covered by our warranty. Labor is not covered under warranty for Parts orders.

Presto Lifts Parts Department
50 Commerce Way, Norton, MA 02766

Telephone: 800-343-9322
FAX: 888-788-6496
Email: Service@PrestoLifts.com
www.PrestoLifts.com

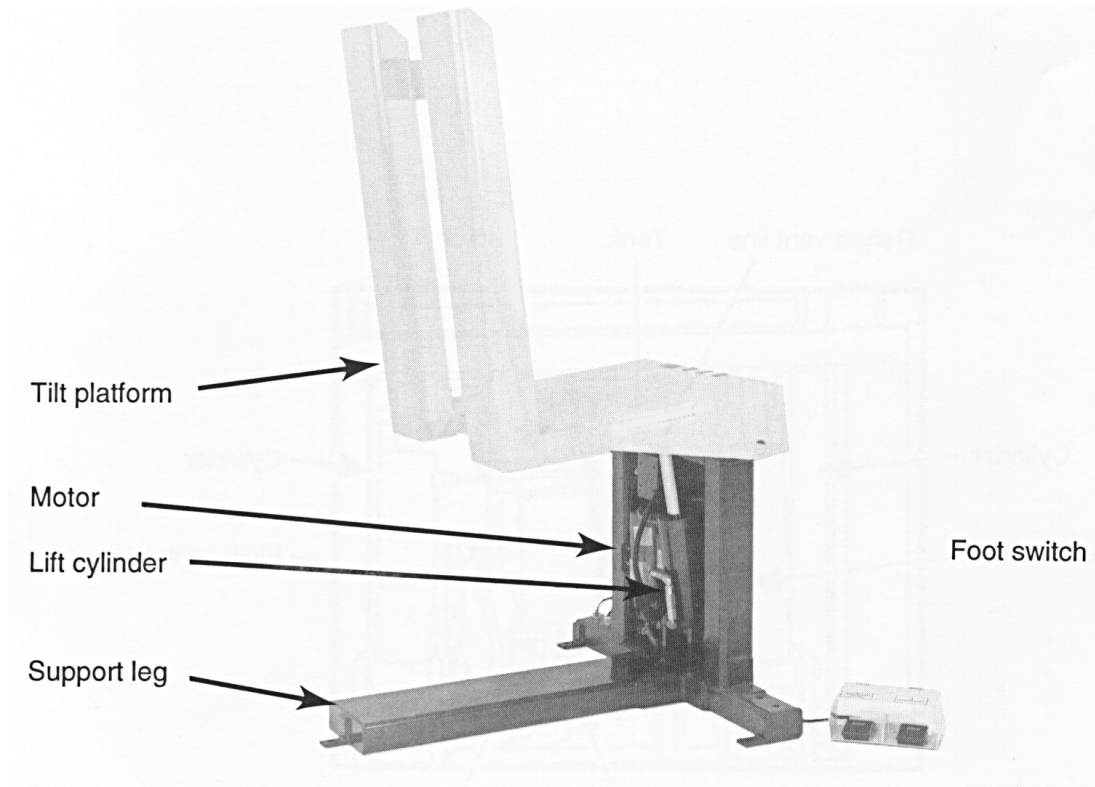

Fig. 12. Parts Identification - Side View

Table 1 – Hydraulic Oil Specifications

If the lift will be used at normal ambient temperatures, Presto Lifts supplies the unit with Conoco Super Hydraulic 32 oil. This may be replaced by any other good quality oil with 150 SSU at 100° F and rust and oxidation inhibitors and anti-wear properties.

If the lift will be used at ambient temperatures below 0°F, use aircraft hydraulic oil. Use Type 15 aircraft hydraulic oil.

The following are equivalent to CONOCO SUPER HYDRAULIC 32:

TYPE	MANUFACTURER
DTE 24	EXXON/MOBIL
NUTO H32	EXXON/MOBIL
AMOCO AW32	CHEVRON (AMOCO CO.)
AW32	CITGO

CAUTION!

It is very important to keep the hydraulic oil free of dirt, dust, metal chips, water, and other contamination. Most of the problems with hydraulic systems are caused by contamination in the oil.

WARNING
 THIS POWER SUPPLY CORD HAS A 3-PRONG GROUNDED PULSAR FOR REMOVAL. ELECTRICITY MUST BE DISCONNECTED FROM THE MACHINE BEFORE ANY MAINTENANCE OR REPAIR WORK IS PERFORMED. ALWAYS USE THE APPROPRIATE LOCKING AND TAGGING PROCEDURES. THIS UNIT WILL REQUIRE A DEGRATED TAMP CIRCUIT BREAKER AND OTHER ELECTRICAL DEVICES. DO NOT OPERATE THIS UNIT WITH AN EXTENSION CORD. COVER THIS SWITCH LINE ON CORD.

CUIDADO
 PARA SEGURIDAD PERSONAL, DESCONECTE EL CABLE DE ALIMENTACION DE LA MAQUINA ANTES DE REALIZAR CUALQUIER TRABAJO DE MANTENIMIENTO O REPARACION. SIEMPRE USE LOS PROCEDIMIENTOS ADECUADOS DE BLOQUEO Y ETIQUETADO. ESTE UNIDAD REQUIERIRA UN INTERRUPTOR DE CIRCUITO DEGRADADO Y OTROS DISPOSITIVOS ELECTRICOS. NO OPERE ESTA UNIDAD CON UN CABLE DE EXTENSION. CUBRA ESTA LINEA EN EL CORDO.

IMPORTANT: 10021381 IS TO BE APPLIED TO 115/1/60 POWER MACHINES ONLY. LOCATE ITEM NO. 10021381 ON POWER CORD 1" AWAY FROM PLUG.

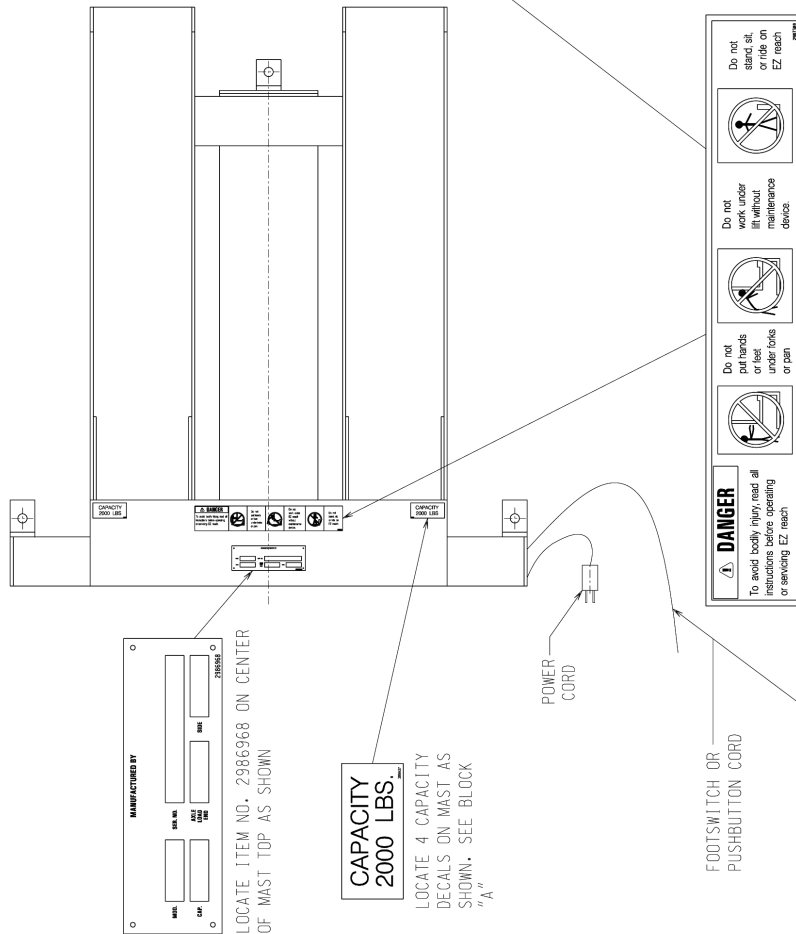

MANUFACTURED BY
 MFG. NO. _____
 DATE _____
 TIME _____
 LOC. _____
 SERIAL NO. _____

LOCATE ITEM NO. 2986968 ON CENTER OF MAST TOP AS SHOWN

CAPACITY 2000 LBS.
 LOCATE 4 CAPACITY DECALS ON MAST AS SHOWN. SEE BLOCK "A"

POWER CORD
 FOOTSWITCH OR PUSHBUTTON CORD

DANGER
 To avoid bodily injury, read all instructions before operating or servicing EZ. reach

Do not put hands or feet under forks or pan

Do not work under lift without maintenance device.

Do not stand, sit or ride on EZ reach

TANK TO BE FULL ONLY WHEN EXHAUSER IS COLLAPSED

THIS MACHINE USES HYDRAULIC FLUID OR EQUIPMENT

NOTICE
 Proper installation is essential to the safe operation of this equipment. Always secure the tank from moving with other appropriate information. Is within your responsibility to read and understand the information provided in this manual. For more information, contact the Customer Service Department.

FRONT VIEW

POWER
 115 VOLTS
 1 PHASE

LOCATE POWER DECAL ON JUNCTION BOX AS SHOWN. SEE BLOCK "B"

CONTROL
 115 VOLTS
 1 PHASE

LOCATE CONTROL DECAL ON JUNCTION BOX AS SHOWN. SEE BLOCK "C"

IMPORTANT LABEL IS TO BE APPLIED TO 115/1/60 POWER MACHINES ONLY.

Figure 13: Labels and Locations

RETURN MATERIALS AUTHORIZATION POLICY

Presto Lifts provides the Return Materials Authorization (RMA) Policy, for specific models, as a courtesy to our distributors in the event they do not receive what they ordered. If a customer wishes to return a Presto Lifts product, please contact the Customer Service Department and request an RMA number. This request must be made on or before the fifteenth calendar day following the date of Presto Lifts' invoice for the merchandise. Not all units are returnable. Quantity orders and special designs cannot be returned under any circumstances. Presto Customer Service reserves the right for final judgment on all product returns.

The RMA number must appear on the outside of any packaging material for a return to be accepted and processed by Presto Lifts. Customers shipping returns from the Continental US, Canada, or Mexico have thirty (30) days from date of RMA issue to have the product arrive at Presto Lifts' facility. All merchandise must arrive Free on Board at Presto Lifts' facility or the shipment will be refused and returned to the sender. All credits are issued less restocking and refurbishing charges, regardless if the merchandise was damaged in transit.

Return addresses: please refer to your RMA for the address to which your product should be returned.

Presto Lift Inc.
715 Highway 77
Manila, Arkansas 72442

Telephone: 800-343-9322
Fax: 888-788-6496

MANY NEEDS REQUIRE MANY OPTIONS...

Presto LIFTS



LET PRESTO MEET THOSE NEEDS!

Call Presto Sales
for stock or
customized lift inquiries:
800-343-9322

Email: sales@prestolifts.com

