

# Lift Stik

PLS52-185

PLS48-230

PLS60-220

PLS48-450

## Installation, Operation and Service Manual

Model Number \_\_\_\_\_

Serial # \_\_\_\_\_

Date Placed in Service \_\_\_\_\_

**IMPORTANT: READ CAREFULLY  
BEFORE INSTALLING OR OPERATING LIFT**

Part orders are subject to a \$50 minimum charge.





<b>⚠ WARNING</b>
Cancer and Reproductive Harm - <a href="http://www.P65Warnings.ca.gov">www.P65Warnings.ca.gov</a>
10095524

**This label (part # 10095524)  
is required by California law.  
For more information visit  
[www.P65Warnings.ca.gov](http://www.P65Warnings.ca.gov).**

# CONTENTS

<b>SECTION 1:</b>	
Introduction.....	4
Responsibility of Owners and Users.....	5
<b>SECTION 2:</b>	
Safety Alert Symbols and Signal Words.....	6
Safety .....	7
<b>SECTION 3:</b>	
Installation.....	7
A. Inspection .....	7
<b>SECTION 4:</b>	
Operation.....	7
A. Operating Instructions.....	7
B. Daily Operations Maintenance Checks .....	8
Operator Instructions .....	8
A. Preparation for Use .....	8
B. Operations .....	9
<b>SECTION 5:</b>	
Battery Maintenance .....	9
A. Preparing to Charge a Battery .....	9
B. Locating the Charger .....	9
C. Precautions .....	9
D. Battery Charger Connection Precautions .....	10
<b>SECTION 6:</b>	
Maintenance.....	13
A. Instructions.....	13
B. Monthly Operations Maintenance Checks .....	13
C. Maintenance .....	13
ORDERING REPLACEMENT PARTS .....	25
RESTOCKING POLICY .....	26
RETURN MAT'LS AUTHORIZATION (RMA) PROCEDURES.....	27
WARRANTY .....	28

## LIST OF FIGURES:

Figure 1 Components Diagram.....	11
Figure 2 Specifications.....	12
Figure 3 Spare Parts.....	14
Figure 4 Chain Routing for PLS48-450.....	15
Figure 5 Changing the PLS48-450 Motor .....	17-19
Figure 6 Wiring Diagrams .....	20
Figure 7 Lift Stik Dimensions.....	21-24

## **SECTION 1**

# **INTRODUCTION**

This manual attempts to provide all of the information necessary for the safe and proper installation, operation and maintenance of Presto Lifts Inc. Lift Stik. It is important that all personnel involved with the installation, maintenance or operator of the stacker read this manual. Additional manuals are available upon request or at [www.prestolifts.com](http://www.prestolifts.com).

Each of the Presto Lift Inc. stackers is equipped with nameplate, serial number and model identifications. Please refer to these numbers when ordering parts or requesting further information.

The Presto Lifts Inc. stackers are designed for lifting, lowering and positioning a wide variety of loads. WHERE UNIQUE SITUATIONS ARISE, WHICH ARE NOT COVERED IN THIS MANUAL, CALL PRESTO LIFTS FOR FURTHER INSTRUCTIONS.

The battery-operated stackers are designed for in-plant/non-hazardous locations only. These units are not for personnel lifting. All equipment is manually propelled and powered vertical travel.

# Responsibility of Owners and Users

## **Inspection and Maintenance**

The device shall be inspected and maintained in proper working order in accordance with Presto's owner's manual.

## **Removal from Service**

Any device not in safe operating condition such as, but not limited to, excessive leakage, missing rollers, pins, or fasteners, any bent or cracked structural members, cut or frayed electric, hydraulic, or pneumatic lines, damaged or malfunctioning controls or safety devices, etc. shall be removed from service until it is repaired to the original manufacturer's standards.

## **Repairs**

All repairs shall be made by qualified personnel in conformance with Presto's instructions.

## **Operators**

Only trained personnel and authorized personnel shall be permitted to operate PowerStak.

## **Before Operation**

Before using the device, the operator shall have:

- Read and/or had explained, and understood, the manufacturer's operating instructions and safety rules.
- Inspected the device for proper operation and condition. Any suspect item shall be carefully examined and a determination made by a qualified person as to whether it constitutes a hazard. All items not in conformance with Presto's specification shall be corrected before further use of the PowerStak.

## **During Operation**

The device shall only be used in accordance with this owner's manual.

- Do not overload.
- Ensure that all safety devices are operational and in place.

## **Modifications or Alterations**

Modifications or alterations to any Presto industrial positioning equipment shall be made only with written permission from Presto.

# SAFETY ALERT SYMBOLS AND SIGNAL WORDS

The safety of all persons operating, maintaining, repairing, or in the vicinity of this equipment is of paramount concern. This is a powerful machine with moving parts, and is capable of causing personal injury if proper precautions are not taken. Therefore, throughout this manual, certain hazards have been identified which may occur in the use of the machine, and there are appropriate instructions or precautions which should be taken to avoid these hazards. In some cases, there are consequences which may occur if instructions or precautions are not followed. Below are the symbols and signal words along with their definitions referenced from ANSI Z535.4 - Product Safety Signs and Labels.

## Safety Alert Symbols

These are the safety alert symbols.. They are used to alert you to potential physical injury hazards. Obey all safety messages that follow this symbol to avoid possible injury or death.



**For use with DANGER signal word**  
(Red Background)



**For use with WARNING signal word**  
(Orange Background)



**For use with CAUTION signal word**  
(Yellow Background)

## Signal Words

The meaning of different signal words as defined by ANSI Standard Z535.4 indicates the relative seriousness of the hazardous situation.



(Red Background)

DANGER indicates a hazardous situation which, if not avoided, will result in death or serious injury.



(Orange Background)

WARNING indicates a hazardous situation which, if not avoided, could result in death or serious injury.



(Yellow Background)

CAUTION, used with the safety alert symbol, indicates a hazardous situation which, if not avoided, could result in minor or moderate injury.



(Blue Background)

NOTICE is used to address practices not related to personal injury.



(Green Background)

SAFETY INSTRUCTIONS (or equivalent) signs indicate safety-related instructions or procedures.

## **SECTION 2**

### **SAFETY**

The battery-operated stackers are very powerful lifts capable of doing large amounts of work.

DO NOT INSTALL OR OPERATE THESE LIFTS WITHOUT CAREFULLY READING THIS MANUAL. In order to provide for the safe operation of these stackers, Presto Lifts Inc. has identified certain hazards that may occur during the installation, maintenance and use of these lifts. For safety reasons these units are designed to be serviced or repaired in the collapsed position. If performed properly, this will greatly reduce the possibility of injury.



**Do not perform any repair work on lifts if there is a load on the forks or platform.**

**Do not perform any repair work if the forks or platform is in the raised position.**

**All personnel must stand clear of the lift while in motion.**

**Do not put hands or feet under the forks or platform.**

**Do not stand underneath the forks or platform.**

**Do not stand in front of the stacker while in motion.**

**Do not stand, sit or climb on the lift.**

**Do not use the lift on soft, uneven or unstable surfaces.**

**Do not exceed the load center or capacity.**

## **SECTION 3**

### **INSTALLATION**

#### **A. INSPECTION:**

Upon receipt of the stacker, inspect the equipment completely to determine if there is any shipping damage, and that the lift is complete. Presto Lifts Inc. tests and inspects every piece of equipment prior to shipment. If damage is apparent, a freight claim must be filed with the freight company. Do not use the lift if there appears to be any damage. With the lift in a collapsed position, check the following:

- 1 Check for signs of damage especially to the back cabinet that houses the battery and power pack.
- 2 Check base frame for dimensions and structural integrity.
- 3 Inspect for any bent or damaged metal parts.

## **SECTION 4**

### **OPERATION**

#### **A. OPERATING INSTRUCTIONS:**

1. To raise lift, push "Lift" button.
2. To lower lift, push "Lower" button.
3. Whenever the control handle is released, the lift stops.

AUTHORIZED OPERATORS SHOULD READ AND UNDERSTAND ALL INSTRUCTIONS, PRECAUTIONS AND WARNINGS. IMPROPER USE OF THIS LIFT COULD RESULT IN INJURY AND/OR DAMAGE TO LOAD AND EQUIPMENT.

- 1 Inspect the lift for damaged or worn parts. *Do not* use if not in safe operating condition.
- 2 Use lift on hard level surfaces only.
- 3 Make sure load is evenly distributed, not loose or unstable, and is as far back on platform or forks as possible. *Do not* pick up loads on tips or forks or edge of platform.
- 4 For fork models, adjust forks to the maximum practical width. Pick up loads on both forks (not one).
- 5 *Do not* overload. Check load center and load weight capacities on manufacturer's nameplate.
- 6 Make sure travel and work area is clear of obstructions.
- 7 Check overhead clearance before lifting loads or transporting.
- 8 Make sure floor lock pad is in firm contact with floor before lifting load, lowering load or using as a workstation.
- 9 Brace or block lift when sliding loads on or off platform or forks.

**B. DAILY OPERATIONS  
MAINTENANCE CHECKS:**

**1. Battery**

- A. Check for corroded and loose terminals.  
A white powder substance will be present if there is any existing corrosion.
- B. Visually inspect for any cracks or damage to the casing.
- C. Check for loose battery tie-downs.

**2. Charger**

- A. Inspect wire connections.
- B. Check power cord for nicks/damage.
- C. Check charger for proper mounting.

**3. Frame Assembly**

- A. Check wheel lock.
- B. Check chain roller assembly connections.
- C. Check for any worn or damaged parts.

**OPERATOR  
INSTRUCTIONS**



**DO NOT** use this lift until you have been trained and authorized to do so.

**DO NOT** operate until you have read all warnings and instructions.

**DO NOT** exceed load center or load weight capacities

**DO NOT** operate until you have checked the conditions of the truck: lift systems, forks, chains, cables and floor lock.

**DO NOT** use if any part is damaged, worn or not working properly.

**DO NOT** use on ramps or inclines. Only smooth level surfaces.

**DO NOT** use for lifting or carrying people.

**DO NOT** handle unbalanced, unstable or loosely stacked loads.

**DO NOT** travel with forks or platform in an elevated position.

**DO NOT** handle high-unsecured loads that could fall backwards.

**DO NOT** allow people to stand or pass under forks or platform with or without load.

**DO NOT** operate when parts of anyone's body may be close to mast structure or any moving parts.

**DO NOT** drop loads on platform or forks.

**DO NOT** alter or modify this lift in any way.

**A. PREPARATION FOR USE**

This lift left our factory in perfect condition. It has been inspected and tested to assure performance standards



have been met.

Visually inspect lift for damage. Check for attachments and accessories that may have been ordered. If there is any damage or missing parts, report it to your carrier and your Presto Lifts dealer immediately.

Remove all metal/plastic bands, cardboard and other material used for shipping purposes.

Check to see if chains are in place, the wheel lock is in working order, and that the lift system is in working order.

Connect battery cable. Check cables and wires on battery charger as well as battery.

## **B. OPERATIONS**

### **PRECAUTIONS:**

**AUTHORIZED OPERATORS SHOULD READ AND UNDERSTAND ALL INSTRUCTIONS, PRECAUTIONS AND WARNINGS. IMPROPER USE OF THIS LIFT TRUCK COULD RESULT IN INJURY AND/ OR DAMAGE TO LOAD AND EQUIPMENT.**

Inspect the lift for damaged or worn parts. Do not use if not in safe operating condition.

Use lift on hard level surfaces only.

Make sure load is evenly distributed (not loose or unstable), and is as far back on forks as possible. Do not pick up loads on tips of forks or edge of platform.

Adjust forks to the maximum practical width. Pick up loads on both forks (not one).

Do not overload: Check load center and load weight capacities on manufacturers name plate.

Make sure travel and work area is clear of obstructions.

Check overhead clearance before lifting loads or transporting.

Make sure floor lock or pad is secured to floor before lifting, lowering or using as a workstation.

Brace or block lift when sliding loads on or off platform or forks.

## **SECTION 5**

# **BATTERY MAINTENANCE**

## **A. PREPARING TO CHARGE A BATTERY**

1. Be sure area around lift and the battery is well ventilated while battery is being charged.
2. The battery terminals, connections and wiring including the plug in the battery box and charger connections should be clean and free of corrosion. When cleaning any of these components wear a face shield or other suitable protective eyewear.
3. For a sealed battery (a battery without cell caps) carefully follow the manufacturer's recharging instructions that are provided with the battery. If you do not have a copy of these instructions or the instructions for the battery charger they are available free of charge by calling Presto Lifts @ 1-800-343-9322.
4. Read, understand and follow all battery and battery charger manufacturer's specific precautions while working with and/or charging batteries.

## **B. LOCATING THE CHARGER**

1. Locate charger as far away from battery as the cables permit.
2. Do not operate charger in a closed area or restrict ventilation in any way.

## **C. PRECAUTIONS FOR GROUNDING AND AC POWER CORD CONNECTION**

**Charger should be grounded to reduce risk of electric shock. Charger is equipped with an electric cord having an equipment-grounding conductor and grounding plug. The plug must be plugged into an outlet that is properly installed and grounded in accordance with all local codes and ordinances.**



**Never alter the AC cord or plug provided. If it will not fit outlet, have proper outlet installed by a qualified electrician. Improper connection can result in a risk of an electric shock.**

#### **D. BATTERY CHARGER CONNECTION PRECAUTIONS**



**Connect and disconnect the DC output plug (or clips) only when the AC cord is disconnected from the electric outlet. Never allow clips to touch each other.**

1. When hooking up the charger, attach the plug into the twist-lock receptacle on the side of the battery box or connect the clips directly to the battery on units that are not pre-wired with a plug on the side of the battery box.

FOR UNITS NOT EQUIPPED WITH A TWIST-LOCK, PREWIRED CHARGER PLUG FOLLOW THESE ADDITIONAL PRECAUTIONS

1. Check polarity of battery posts. POSITIVE (POS, P, +) battery post usually has larger diameter than NEGATIVE (NEG, N, -) battery post.

2. Determine which post of battery is grounded (connected) to the chassis of the machine. Connect the NEGATIVE (Black) clip from the battery charger to the machine chassis as far away from the battery as possible.

3. The POSITIVE (red or white) clip from the battery charger to the POSITIVE (POS, P, +) post of the battery.

4. When making each connection, twist or rock clip back and forth several times to make a good connection and to reduce the risk of a clip slipping off and creating a spark. Do not twist or rock clip on the battery after the second clip connection is made.

5. When disconnecting the charger, disconnect AC cord from the electrical outlet before removing any clips from battery or chassis.

IF THESE INSTRUCTIONS ARE NOT CLEAR OR IF THERE ARE ANY QUESTIONS PLEASE CONTACT PRESTO LIFTS INC.

**Figure 1: Components Diagram**

ITEM	DESCRIPTION
1	Motor
2	Battery
3	Circuit board
5	Control unit
6	Caster with brake
7	Caster, fixed wheel
8	Caster, fixed wheel
11	Main switch
12	Battery charger

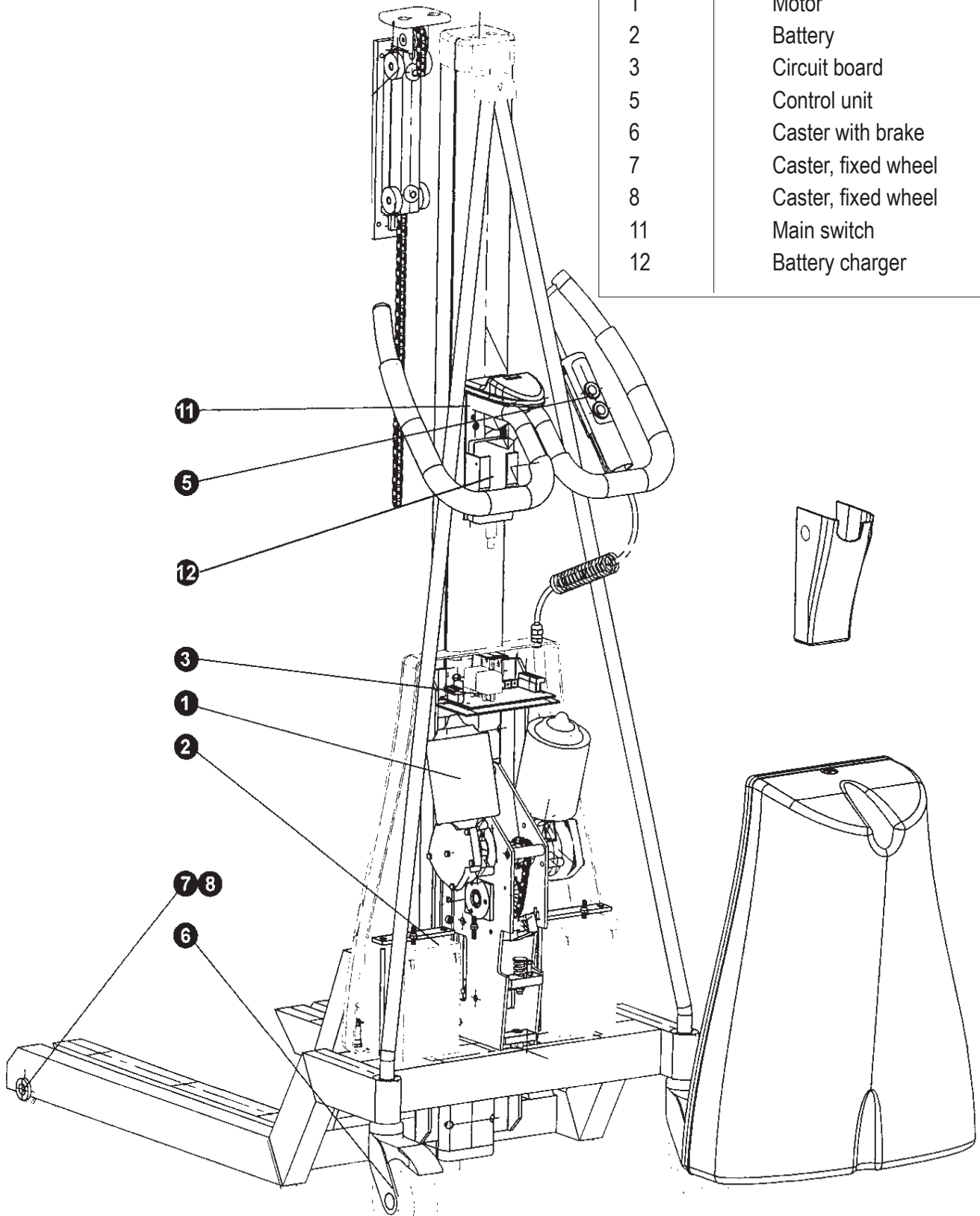

## Figure 2: Specifications

The maximum load refers to the load being uniformly distributed over the entire platform on the basic performance of each work positioner model. If the accessory is added by the purchaser, a new weight decal might be required on the work positioner.

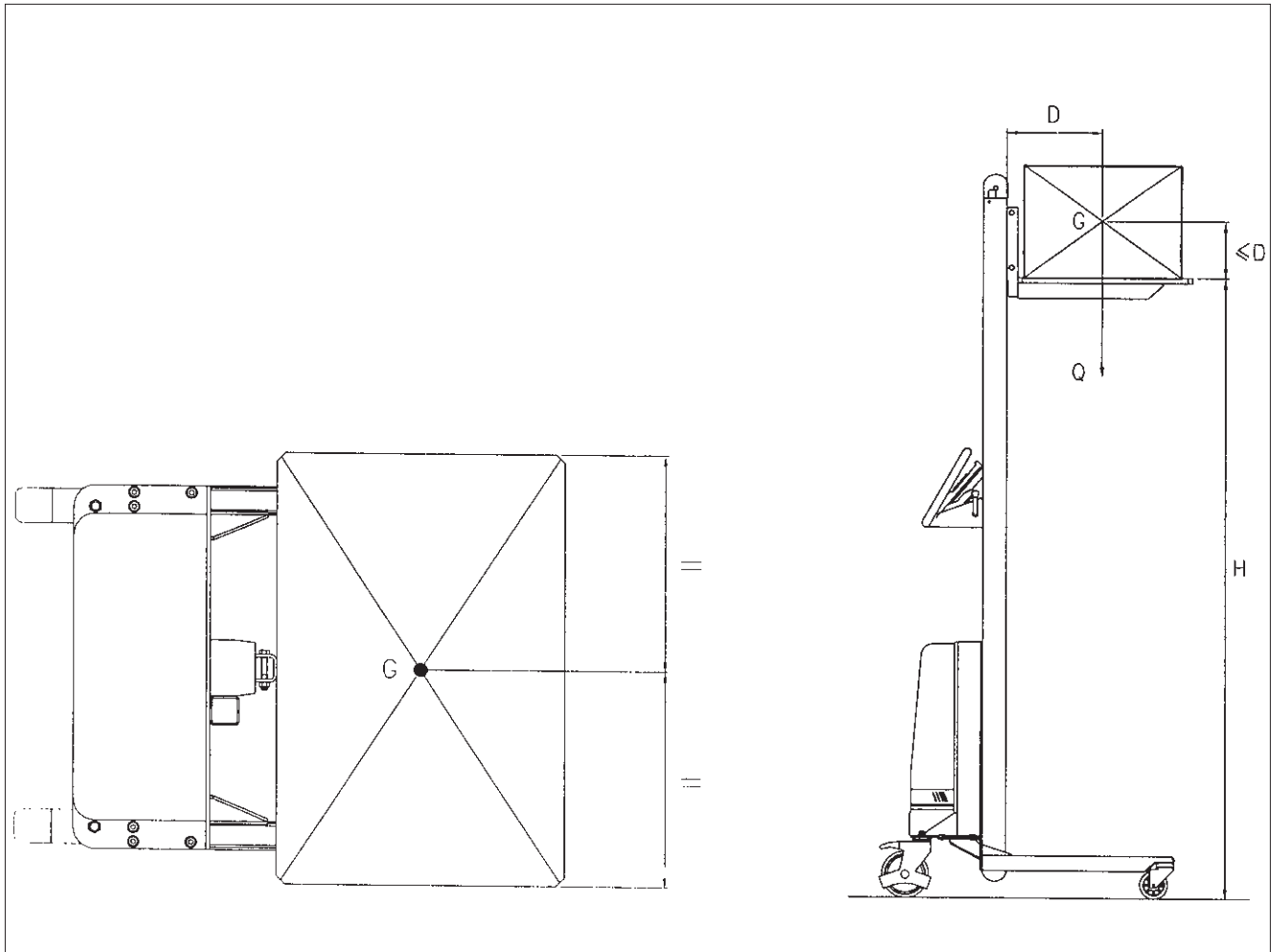

G = Center of gravity

H = Maximum platform height

Q = Maximum permitted load (capacity)

D = Maximum center of gravity. Distance from the mast in relation to the platform/attachment area.

D may not exceed half the platform length

Please contact Presto Lifts Inc. to discuss specific load if it does not meet standard criteria.

## **SECTION 6**

# **MAINTENANCE**

Operation of Presto Lift Stik is very simple — as is their construction. They require very little maintenance. Reasonable care will result in excellent trouble-free performance. Presto Lift Stik's are designed for one-person operation and ease of performance.

### **A. INSTRUCTIONS:**

- 1 Grease wheels and casters at least once a month to maintain easy roll of lift.
- 2 *Do not* overload your lift.
- 3 Lubricate monthly with PTFE Dry Workshop Lube or equivalent.

### **B. MONTHLY OPERATIONS MAINTENANCE CHECKS:**

#### **1. Battery (maintenance free)**

- A. Clean terminals.

#### **2. Frame Assembly**

- A. Clean and lubricate all roller bearings and cam followers.
- B. Clean and inspect all welds.
- C. Check wheels for wear and damage.
- D. Inspect nameplate for legibility. Place the serial and model number shown on the nameplate on the cover of the manual for future reference.

### **C. MAINTENANCE**

The attached bulletin outlines maintenance instructions and parts. A visual check should be made on a daily basis to assure the safety of the lift.

### **Operator Daily Checks**

**DAMAGE:** Check for bent, dented, worn or broken parts.

**WHEELS AND CASTERS:** Check for wear and that they are turning smoothly.

**LIFT CHAINS:** Check to see that they are in place and not loose.

**FORKS:** Check that they are in place and stable.

**LIFT SYSTEM:** Check to assure that there is no binding or excessive play in the platform or fork back plate.

**WHEEL LOCK:** Check to assure pad is contacting the wheel and holds truck in place.

**CABLES; WIRES:** Check that there are no loose cables or wires.



**DO NOT USE LIFT IF IT IS NOT  
OPERATING PROPERLY,  
OR APPEARS UNSAFE IN ANY WAY!**

**Figure 3: SPARE PARTS**

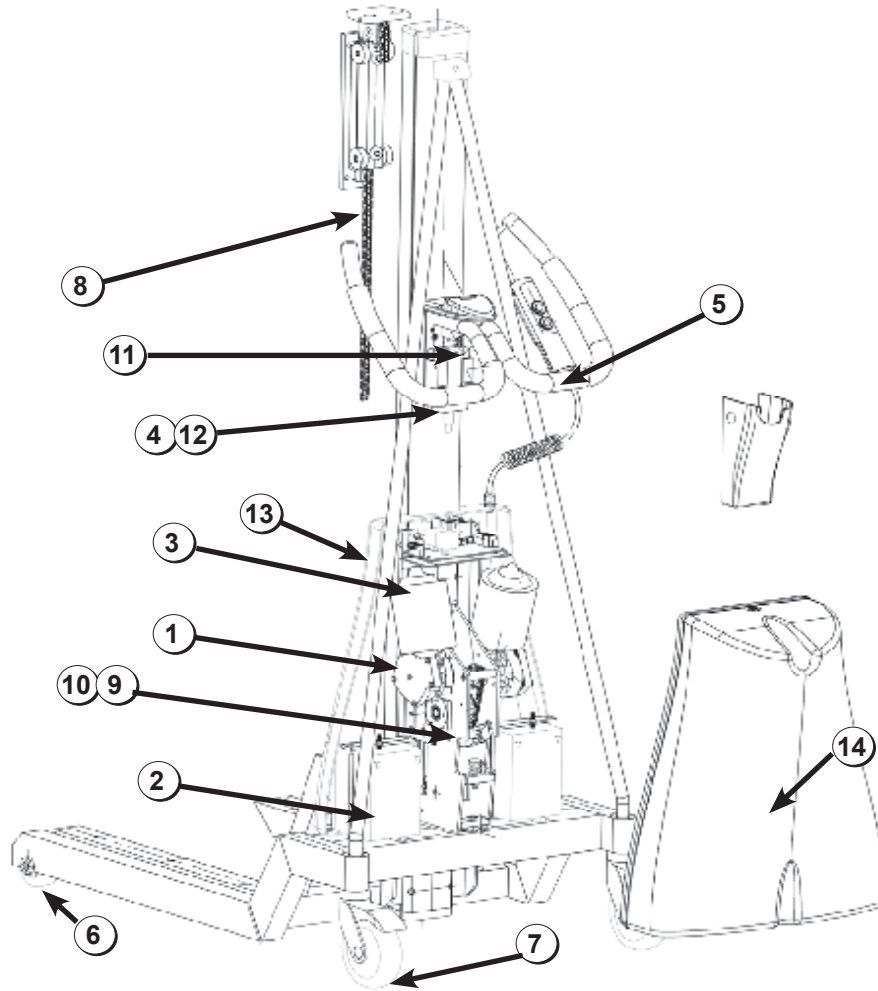

		PLS52-185	PLS48-230	PLS60-220	PLS48-450
1	Motor	Contact Parts Department			
2	Battery	2999100 *	2999100 *	2999100 *	10037904 *
3	Circuit board	Contact Parts Department			
4	Charger cable	R86007-02	R86007-02	R86007-02	R86007-02
5	Control unit w/ cable	R86005	R86005	R86005	R86005
6	Front Wheel	R84251	R86003	R86003	R84298
7	Rear Swivel Wheel	R84250	R84297	R84297	R84297
8	Lift Chain	R86009	R86011	R86012	R86015
9	Transmission Chain	-	-	-	R86016
10	Sprocket wheel kit	R86019	R86020	R86020	R86019
11	Main switch	R86004	R86004	R86004	R86004
12	Battery charger	R84242**	R84242**	R84242**	R84242**
13	Front Shroud	10038826	10038828	10038828	10038828
14	Rear Shroud	10038827	10038829	10038829	10038829
	Up/Down Limit Switch	10044314	10044314	10044314	10044314

\* The repair parts battery will be different than the original, but it will functionally do the same job.

\*\* For machines manufactured in October 2005 or newer.

Note: (Lift Stiks require 2 batteries each)

**Figure 4:**  
**CHAIN ROUTING**  
**PLS48-450**

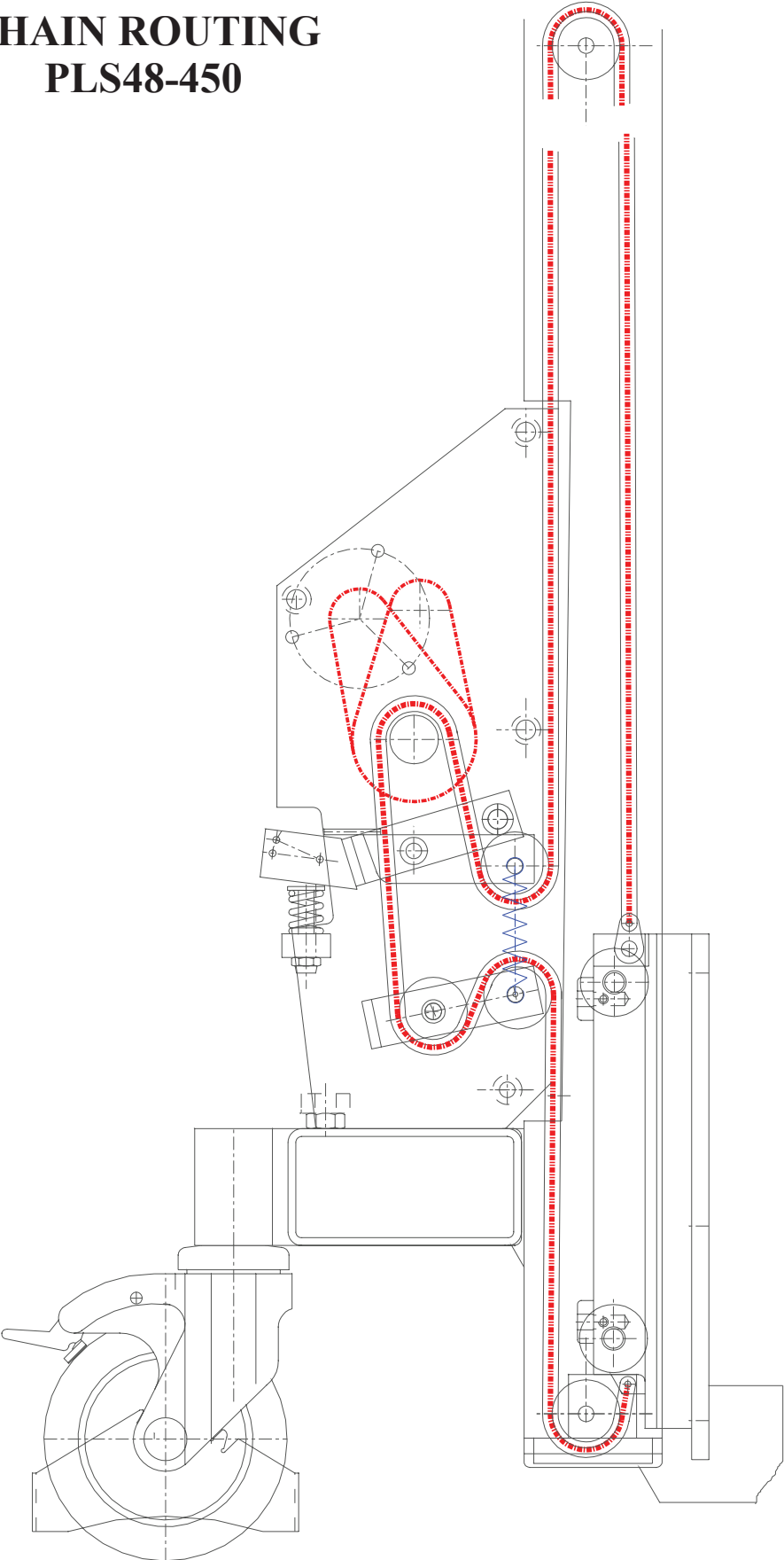

## Changing the PLS48-450 Motor

1. Remove the fork/lift platform of the lift.
2. When possible, take the cart (1) to the bottom position so that there would be a small crack between the cart and the bottom of the mast (2).
3. Remove the battery.
4. Detatch the cords of the engine (3, 4) and the swing (5), mark the cord colours and attachment places for easier re-assembly.
5. Remove the chain tension springs – 2pcs (7).
6. Remove the swing (5, 6) attachment bolts (8)
7. Remove the bottom of the mast (2).
8. Open the bottom chain lock (9) of the cart (1).
9. Unwind the bolts (11) of the motor pack (10) (7pcs).
10. Remove the motor pack from the lift.
11. Unwind the motor attachment bolts.
12. Remove the drive chains (13).
13. Remove the motors (3, 4).
14. Change the chain tensioner of the left motor (14).
15. Place the left motor (3) and the left drive chain.
16. Tighten the left drive chain and the motor bolts.
17. Place the right motor (4) and the right drive chain.
18. Place the right drive chain and motor bolts.
19. Place the motor pack (10).
20. Pull the chain through the motor pack, so that when assembled, it would be possible to compare to the scheme supplied.
21. Attatch the chain to the cart (1).
22. Attatch the bottom of the mast (2).
23. Place the swings (5, 6) and tighten the bolts (8) so that the swings would move freely.
24. Place the chain tension bolts (7).
25. Place the cords and batteries for the swings and motors.
26. Place the fork (platform).
27. When needed, regulate the position of the motor chain wheels so that the drive chains would not rattle, tighten the chain wheel stop screws.



**Figure 5: Changing the PLS48-450 Motor**  
(Pages 14-16)

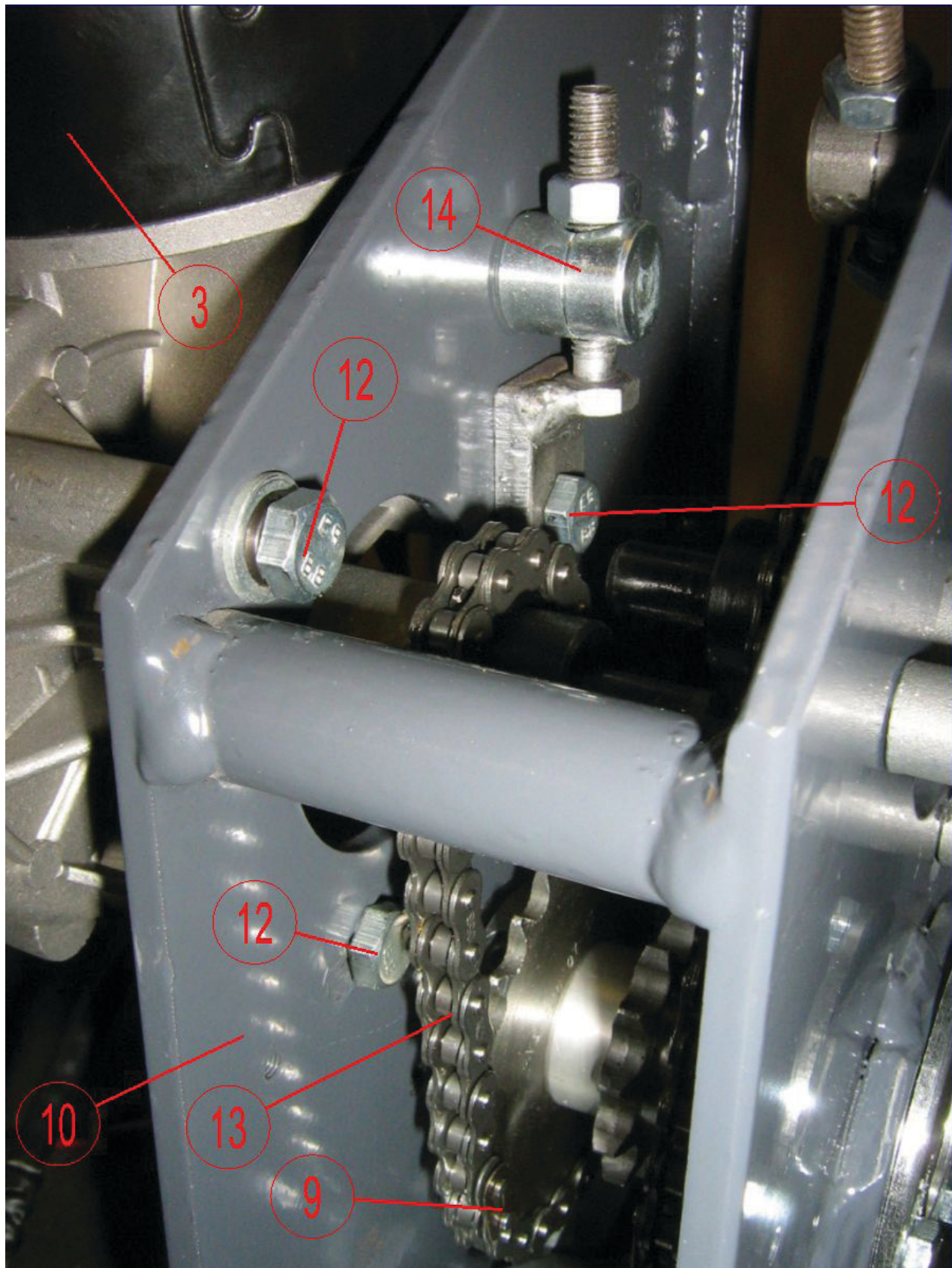

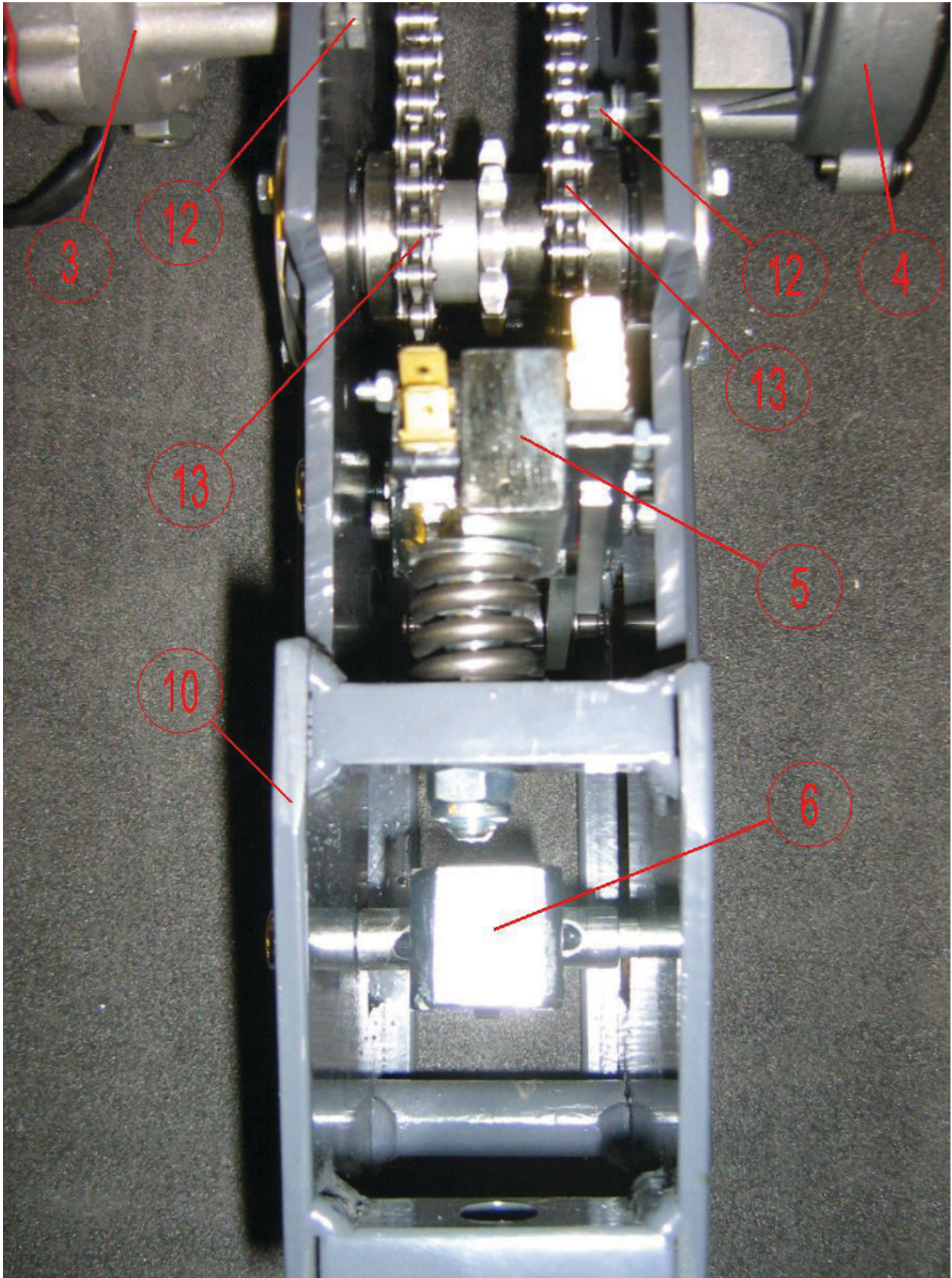

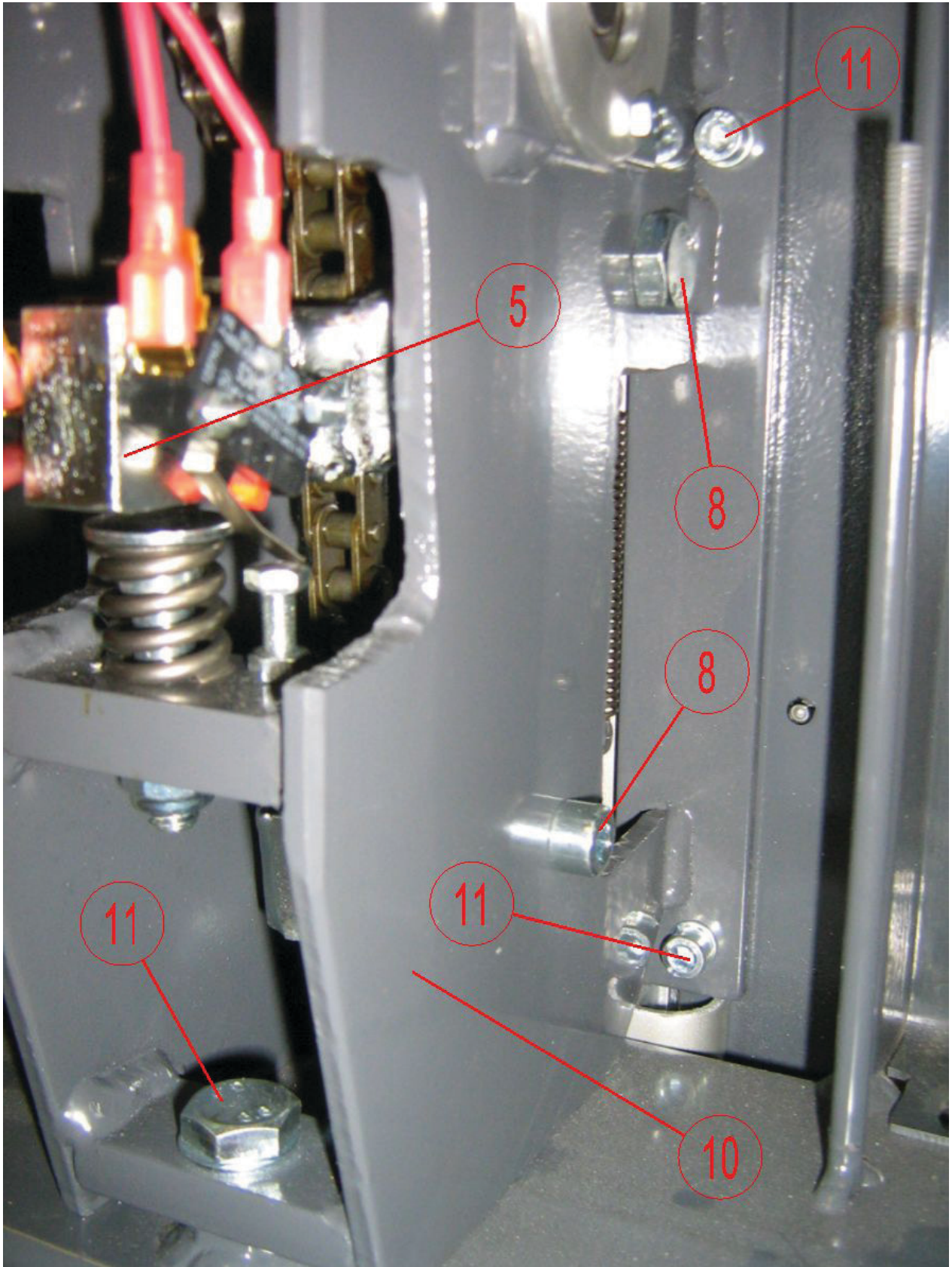

# Figure 6: Wiring Diagrams

## Electrical Diagram PLS52-185, PLS48-230, PLS60-220

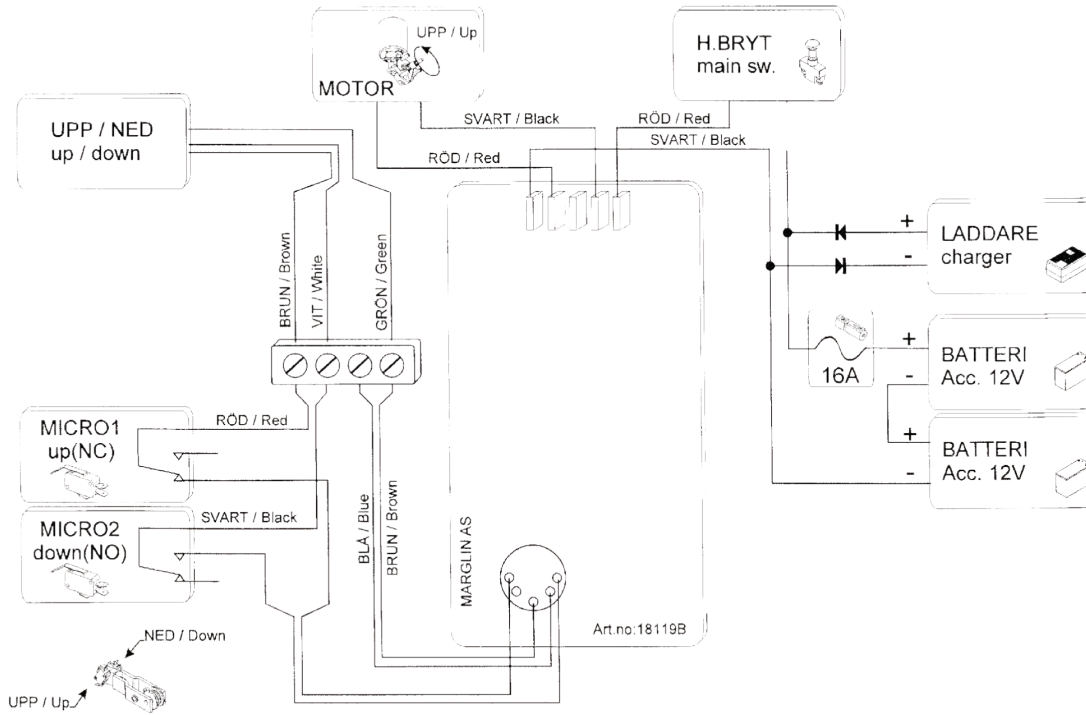

## Electrical Diagram PLS48-450

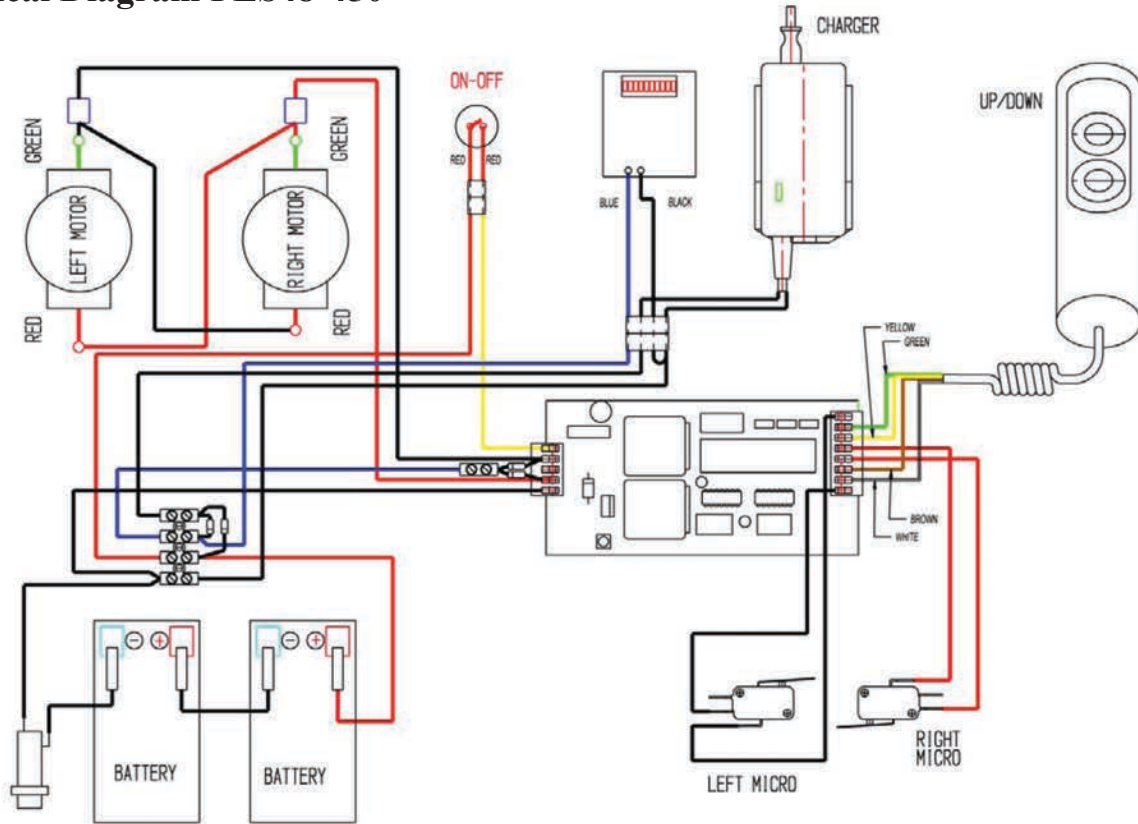
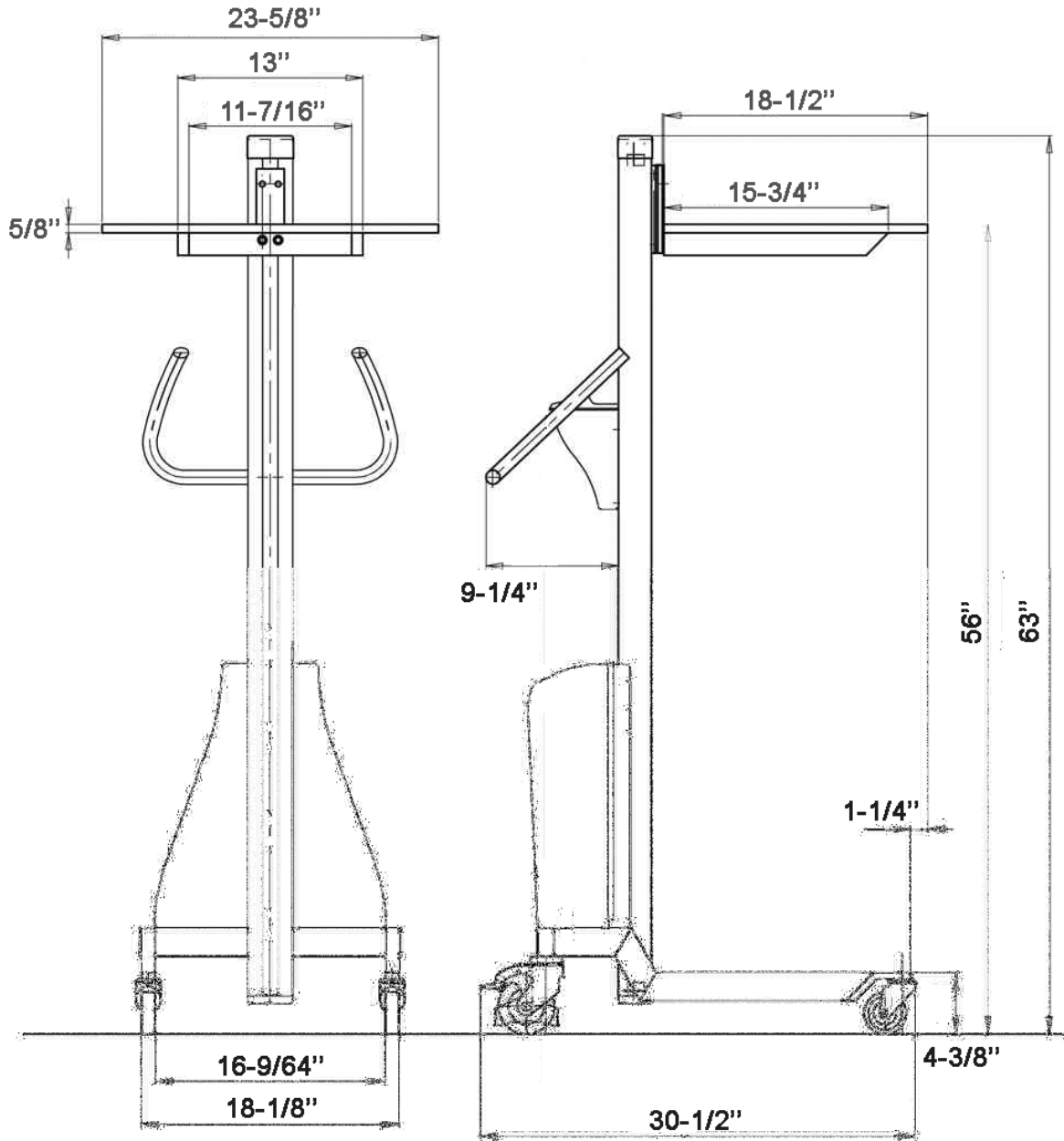

Figure 7: Lift Stik Dimensions (Pages 18-21)

# PRESTO LIFT STIK

## PLS52-185



MODEL NUMBER	LIFTING CAPACITY (lbs.)	RAISED HEIGHT (inches)	LOWERED HEIGHT (inches)	LENGTH (inches)	WIDTH (inches)	HEIGHT	PLATFORM SIZE (inches) (w x l)	BATTERY	CHARGER	WEIGHT INCL. (lbs.)
PLS52-185	185	56	5	31	23-5/8	63"	18-1/2 x 23-1/2	24V/7,2Ah 1,5A	115V	86

# PRESTO LIFT STIK

## PLS48-230

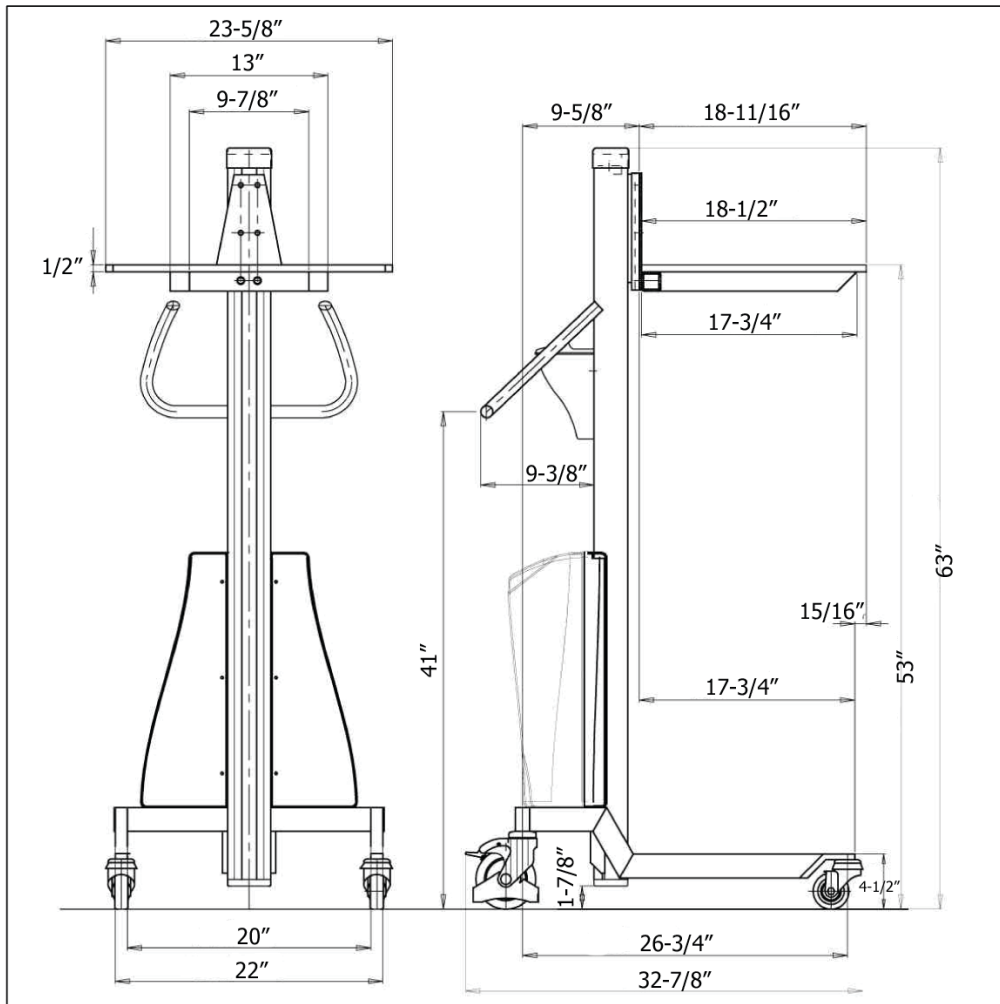

MODEL NUMBER	LIFTING CAPACITY (lbs.)	MAXIMUM HEIGHT (inches)	MINIMUM HEIGHT (inches)	LENGTH (inches)	WIDTH (inches)	HEIGHT	PLATFORM SIZE (inches) (w x l)	BATTERY	CHARGER	WEIGHT INCL. EMB (lbs.)
PLS48-230	230	53	5-1/4	33-1/4	23-3/4	63'	18 X 23	24 VDC	115V	93

# PRESTO LIFT STIK

## PLS60-220

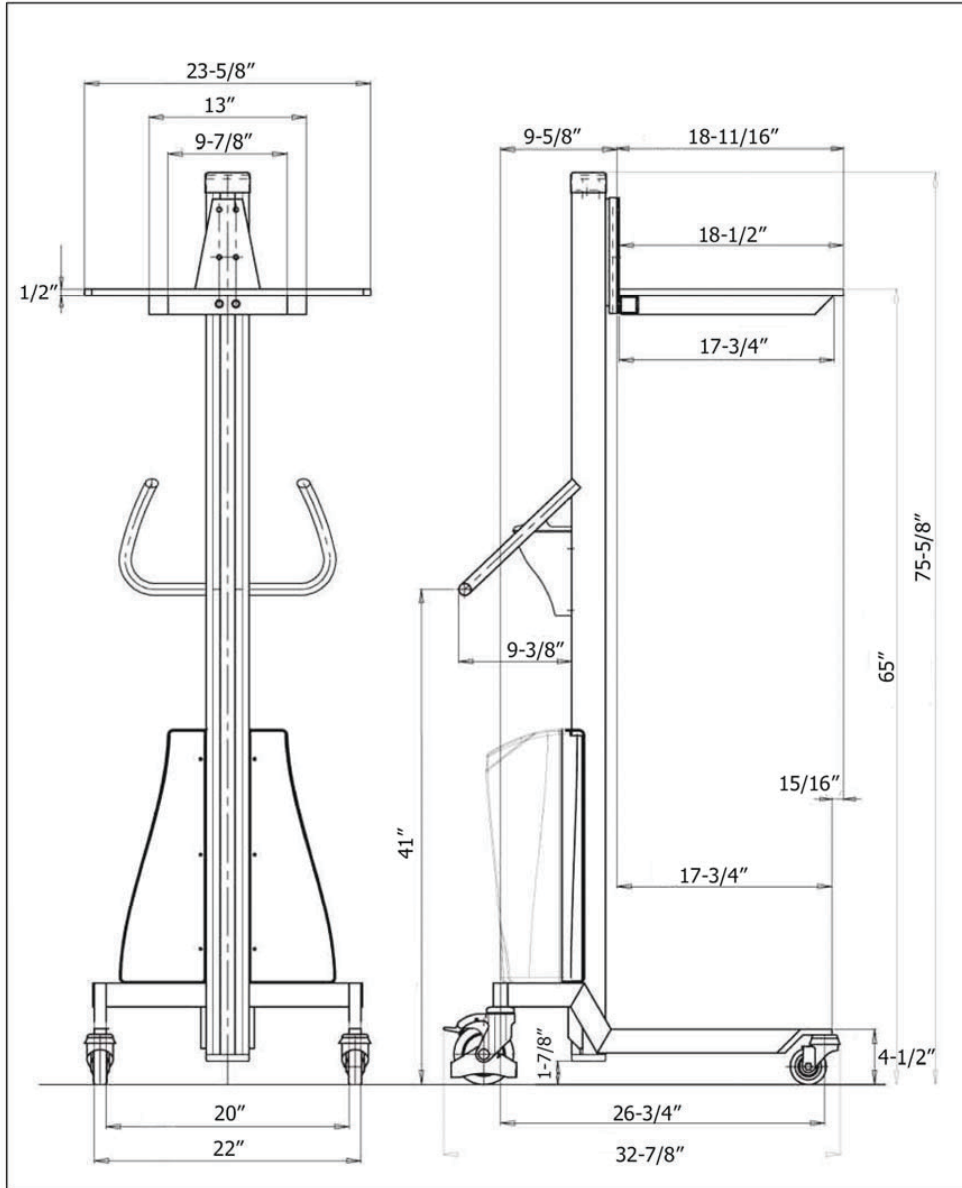

MODEL NUMBER	LIFTING CAPACITY (lbs.)	MAXIMUM HEIGHT (inches)	MINIMUM HEIGHT (inches)	LENGTH (inches)	WIDTH (inches)	HEIGHT	PLATFORM SIZE (inches) (w x l)	BATTERY	CHARGER	WEIGHT INCL. EMB (lbs.)
PLS60-220	220	65	5-1/4	33-1/4	23-3/4	75-1/2	18 X 23	24 VDC	115V	99

# PRESTO LIFT STIK

## PLS48-450

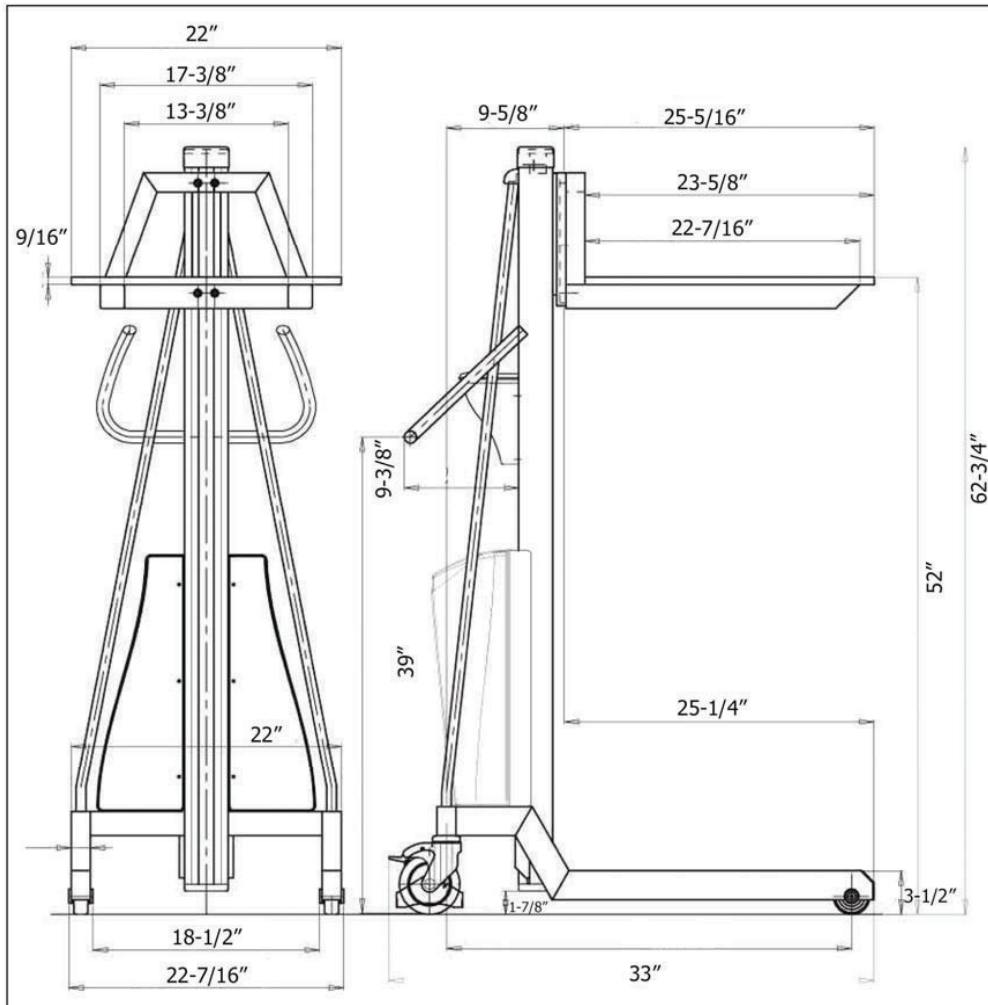

MODEL NUMBER	LIFTING CAPACITY (lbs.)	MAXIMUM HEIGHT (inches)	MINIMUM HEIGHT (inches)	LENGTH (inches)	WIDTH (inches)	HEIGHT	PLATFORM SIZE (inches) (w x l)	BATTERY	CHARGER	WEIGHT INCL. EMB (lbs.)
PLS48-450	450	52	4-1/8	40	22	62-1/2	22 X 23	24V / 12ah	1.5A/115V	141



## Ordering Replacement Parts

Presto Lifts has carefully chosen the components in your unit to be the best available for the purpose. Replacement parts should be identical to the original equipment. Presto Lifts will not be responsible for equipment failures resulting from the use of incorrect replacement parts or from unauthorized modifications to the unit.

Presto Lifts can supply all replacement parts for your lift. With your order, please include the model number and the serial number of the unit. You can find these numbers on the name plate. This plate is located within the cabinet, or the angle iron cylinder cross support.

To order replacement parts, please call the Presto Parts Department. Parts are shipped subject to the following terms:

- FOB factory
- Returns only with the approval of our parts department.
- Credit cards preferred (except parts covered by warranty).
- Freight collect for truck (except parts covered by warranty).
- Freight - prepaid and invoice for small parcel shipments (except parts covered by warranty).
- The warranty for repair parts is 30 days from date of shipment.

Parts replaced under warranty are on a “charge-credit” basis. We will invoice you when we ship the replacement part, then credit you when you return the worn or damaged part, and we verify that it is covered by our warranty. Labor is not covered under warranty for Parts orders.

### Presto Lifts Parts Department

50 Commerce Way

Norton, MA 02766

Telephone: 800-343-9322

FAX: 888-788-6496

Email: [Service@PrestoLifts.com](mailto:Service@PrestoLifts.com)

**[www.PrestoLifts.com](http://www.PrestoLifts.com)**

## **PARTS**

Standard parts may be returned with a 20% restocking fee. Modified or custom-engineered parts are not returnable. Unfortunately, due to potentially concealed damage, all sales of electrical assemblies are final.

## **QUALITY ISSUES**

Should you feel there is a quality problem, please contact the seller to ask questions and gather information on how to rectify the issue. Presto Lift Inc. reserves the right to determine potential credits, as a result of factory defects, based on its inspection of the merchandise.

## **GENERAL**

All products shipped from our factory have passed Quality Assurance inspection and testing. The carrier of choice has signed for, and accepted the product in new working condition. The customer should inspect to ensure it is not received damaged, has no concealed damage or is not incomplete. Parts orders are determined to be complete based upon Presto Lift, Inc. inspection sheets and carrier shipping weights.

## **RETURN GOODS AUTHORIZATION POLICY**

Presto Lifts provides the Return Goods Authorization (RGA) Policy, for specific models, as a courtesy to our distributors in the event they do not receive what they ordered. If a customer wishes to return a Presto Lifts product, please contact the Customer Service Department and request an RGA number. This request must be made on or before the fifteenth calendar day following the date of Presto Lifts' invoice for the merchandise. Not all units are returnable. Quantity orders and special designs cannot be returned under any circumstances. Presto Customer Service reserves the right for final judgment on all product returns.

The RGA number must appear on the outside of any packaging material for a return to be accepted and processed by Presto Lifts. Customers shipping returns from the Continental US, Canada, or Mexico have thirty (30) days from date of RGA issue to have the product arrive at Presto Lifts' facility. All merchandise must arrive Free on Board at Presto Lifts' facility or the shipment will be refused and returned to the sender. All credits are issued less restocking and refurbishing charges, regardless if the merchandise was damaged in transit.

Return addresses: please refer to your RMA for the address to which your product should be returned.

Presto Lift Inc.  
715 Highway 77  
Manila, Arkansas 72442

Telephone: 800-343-9322  
Fax: 888-788-6496

# Presto Lifts Limited Warranty Policy

Presto Lifts warrants this product to be free from defects in material or workmanship for the duration of the warranty period. Warranty periods vary and begin on the date of shipment. For specific warranty information, contact Presto Lifts with the machine's serial number.

Any claim for breach of this warranty must be received in writing by Presto Lifts within the warranty period. Warranties shall not cover failure or defective operation, caused by misuse, misapplication, negligence or accident, exceeding recommended capacities, or any alteration or repair of the item purchased which has not been authorized by Presto Lifts. Except as set forth herein, Presto Lifts makes no other warranties, express or implied, including THE WARRANTIES OF MERCHANTABILITY AND OF FITNESS FOR A PARTICULAR PURPOSE, all of which ARE HEREBY EXCLUDED.

Presto Lifts meets the labeling requirements of California's Proposition 65. Presto Lifts makes no warranty or representation with respect to the compliance of any product with other State or local safety or product standard codes and any failure to comply with such codes shall not be considered a defect of material or workmanship under this warranty. Presto Lifts shall not be liable for any direct or consequential damages arising out of such non-compliance.

Presto Lifts' obligations under any warranty or for any other damages which may arise under any sale, agreement, or contract, are limited to the replacement or repair of defective components at its factory or another location at Presto Lifts' discretion. This is buyer's sole remedy under any such warranty, sale, agreement, or contract. Presto Lifts will not be liable for consequential, incidental, exemplary, or punitive damages of any kind resulting from a breach of any warranty that it has provided or for breach of any term of any sale, agreement, or contract. Any warranty may be altered only in writing by Presto Lifts.

All commodities, software, or technology purchased from Presto Lifts are subject to the export and re-export control laws and regulations of the United States, including but not limited to the Export Administration Regulations ("EAR") and Department of the Treasury Office of Foreign Asset Controls ("OFAC") Regulations. Presto Lifts expects all distributors and customers to comply with these laws and regulations. Without limiting the foregoing, the distributor/customer cannot, without proper authorization from the applicable United States Government Agency, export, re-export, or transfer any commodity, software, or technology purchased from Presto Lifts, either directly or indirectly, to any entity, country, or national of any country in breach of such laws and regulations. Furthermore, Presto Lifts expects that the distributor/customer shall indemnify and hold harmless Presto Lifts from and against any claim, proceeding, action, fine, loss, cost and damages arising out of or relating to any noncompliance with export control regulations by distributor/customer, and distributor/customer are expected to compensate Presto Lifts for all losses and expenses resulting thereof, unless such noncompliance was clearly not caused by fault of the distributor/customer.